

SERVICE MANUAL

Models

**RGX1800, RGX2400,
RGX3500, RGX5500
Generators**

PUB-GS0597B
Rev. 8/98

CONTENTS

<i>Section</i>	<i>Title</i>	<i>Page</i>
1.	SPECIFICATIONS	1
2.	PERFORMANCE CURVES	3
2-1	Model RGX1800	3
2-2	Model RGX2400	5
2-3	Model RGX3500	8
2-4	Model RGX5500	11
2-5	DC OUTPUT	14
3.	FEATURES	15
4.	GENERAL DESCRIPTION OF THE GENERATOR	16
4-1	External View of Generator	16
4-2	Control Panel	17
4-3	Location of Serial Number and Specification Number	31
5.	CONSTRUCTION AND FUNCTION	32
5-1	Construction	32
5-2	Function	32
5-3	Description of Generator Operation	36
6.	SAFETY PRECAUTIONS	39
7.	RANGE OF APPLICATIONS	40
8.	MEASURING PROCEDURES	43
8-1	Measuring Instruments	43
8-2	AC Output Measuring	46
8-3	Measuring Insulation Resistance	46
9.	CHECKING FUNCTIONAL MEMBERS	48
9-1	Pilot Lamp	48
9-2	AC Receptacles	48
9-3	Circuit Breaker	49
9-4	Stator	49
9-5	Rotor	50
9-6	Condenser	50
9-7	Diode Rectifier	51
10.	DISASSEMBLY AND ASSEMBLY	52
10-1	Preparation and Precautions	52
10-2	Special Tools for Disassembly and Assembly	52
10-3	Disassembly Procedures	53
10-4	Assembly Procedures	61
10-5	Checking, Disassembly and Reassembly of the Control Box	68

<i>Section</i>	<i>Title</i>	<i>Page</i>
11. TROUBLE SHOOTING	69
11-1	No AC Output	69
11-2	AC voltage is too high or too low	71
11-3	AC voltage is normal at no-load, but the load cannot be applied	72
11-4	No DC Output	73
11-5	Idle Control	74
12. WIRING DIAGRAM	77

1. SPECIFICATIONS

Model		RGX1800				RGX2400				
ALTERNATOR	Type	Brushless, Revolving Field, Self-Exciting, 2-Pole, Single Phase								
	AC	Frequency	50Hz		60Hz		50Hz		60Hz	
		Maximum Output	1500W		1800W		2000W		2400W	
		Rated Output	1300W		1500W		1700W		2000W	
	Voltage	Rated	110V	11.8A	110V	13.6A	110V	15.5A	110V	18.2A
			220V	5.9A	120V	12.5A	220V	7.7A	120V	16.7A
			240V	5.4A	220V	6.8A	240V	7.1A	220V	9.1A
		Current	110V/220V	11.8A/5.9A	110V/220V	13.6A/6.8A	110V/220V	15.5A/7.7A	110V/220V	18.2A/9.1A
			—	—	120V/240V	12.5A/6.3A	—	—	120V/240V	16.7A/8.3A
	Power Factor	1.0								
DC Output	12V-8.3A (100W)									
Voltage Regulator	Condenser Type									
Voltage Regulation	Within 10%									
ENGINE	Type	Robin Air-Cooled 4-Cycle Gasoline Engine								
	Model	EY20D								
	Displacement	183 cc (11.17 cu. in.)								
	Rated Output	3.5 HP/3600 rpm								
	Fuel	Automobile Gasoline								
	Fuel Tank Capacity	10 liters (2.64 U.S. gal.)								
	Fuel Consumption Ratio (at Rated Output)	50Hz: 1.0 liters/hour 60Hz: 1.3 liters/hour				50Hz: 1.1 liters/hour 60Hz: 1.4 liters/hour				
	Oil Capacity	600 cc								
	Starting System	Recoil Starter								
Dimensions L × W × H	552 × 377 × 482 mm (21.7 × 14.8 × 19.0 in.)									
Dry Weight	45 kg (97 lbs.)				45.5 kg (100 lbs.)					

Model		RGX3500				RGX5500				
ALTERNATOR	Type	Brushless, Revolving Field, Self-Exciting, 2-Pole, Single Phase								
	AC	Frequency	50Hz		60Hz		50Hz		60Hz	
		Maximum Output	3000W		3500W		5000W		5500W	
		Rated Output	2500W		3000W		4400W		4800W	
		Voltage	Rated	110V	22.7A	110V	26.4A	110V	40A	110V
	220V			11.4A	120V	24.2A	220V	20A	120V	40A
	240V		10.4A	220V	13.2A	240V	18.3A	220V	21.8A	
	Current		110V/220V	22.7A/11.4A	110V/220V	26.4A/13.2A	110V/220V	40A/20A	110V/220V	43.6A/21.8A
			—	—	120V/240V	24.2A/12.1A	—	—	120V/240V	40A/20A
	Power Factor	1.0								
DC Output	12V-8.3A (100W)									
Voltage Regulator	Condenser Type									
Voltage Regulation	Within 10%									
ENGINE	Type	Robin Air-Cooled 4-Cycle Gasoline Engine								
	Model	EY28D				EY40D				
	Displacement	273 cc (16.66 cu. in.)				388 cc (23.68 cu. in.)				
	Rated Output	5.5 HP/3600 rpm				8.0 HP/3600 rpm				
	Fuel	Automobile Gasoline								
	Fuel Tank Capacity	13 liters (3.43 U.S. gal.)				15.5 liters (4.10 U.S. gal.)				
	Fuel Consumption Ratio (at Rated Output)	50Hz: 1.8 liters/hour 60Hz: 2.1 liters/hour				50Hz: 2.7 liters/hour 60Hz: 3.1 liters/hour				
	Oil Capacity	850 cc				1200 cc				
Starting System	Recoil Starter and Optional Electric Starter									
Dimensions L × W × H	552 × 413 × 520 mm (21.7 × 16.3 × 20.5 in.)				635 × 448 × 596 mm (25.0 × 17.6 × 23.5 in.)					
Dry Weight	56 kg (123.5 lbs.)				76 kg (167.6 lbs.)					

2. PERFORMANCE CURVES

2-1 MODEL RGX1800

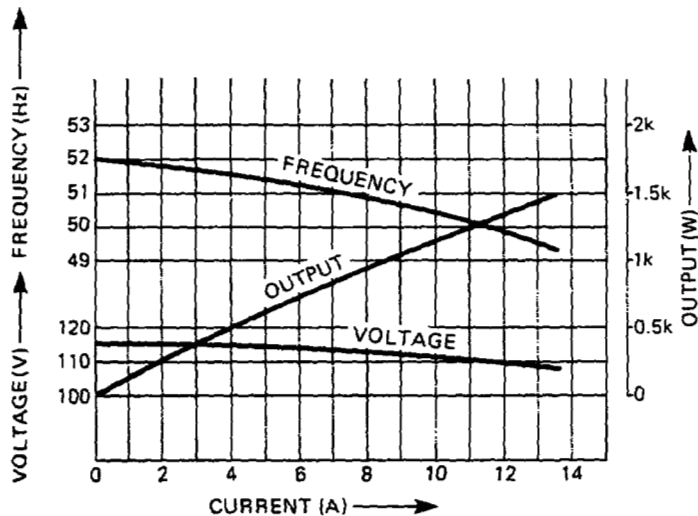

RGX1800

Output Max. 1500W
 Rated 1300W
 Frequency 50Hz
 Voltage 110V

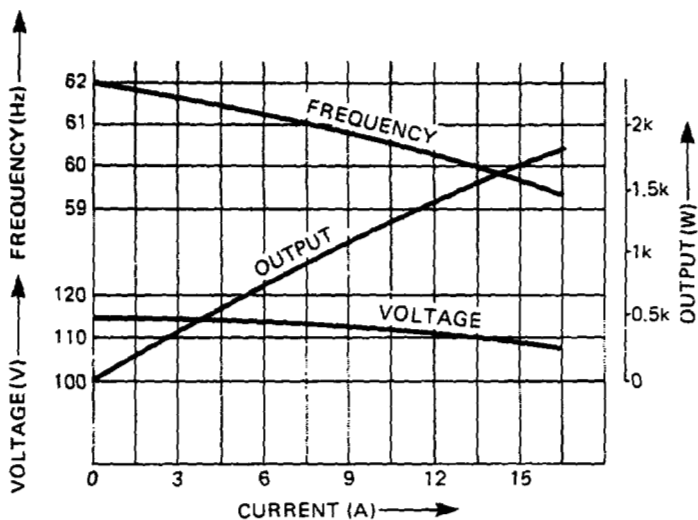

RGX1800

Output Max. 1800W
 Rated 1500W
 Frequency 60Hz
 Voltage 110V

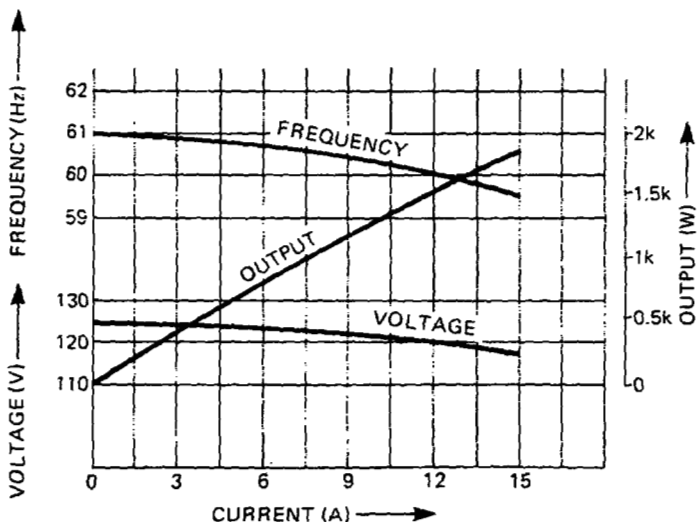

RGX1800

Output Max. 1800W
 Rated 1500W
 Frequency 60Hz
 Voltage 120V

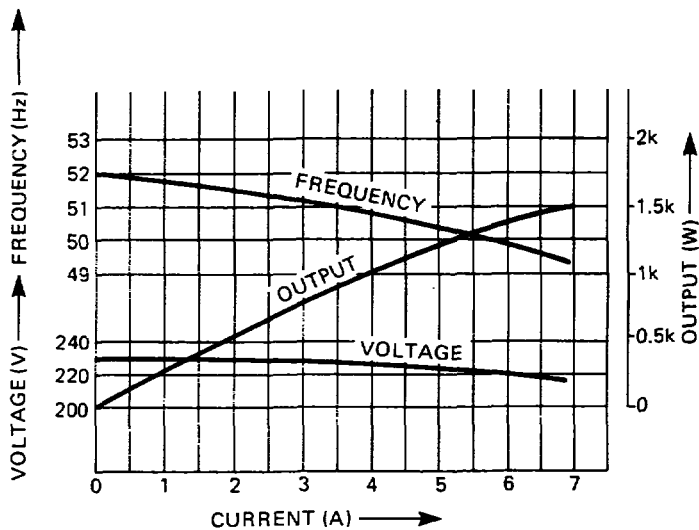

RGX1800

Output Max. 1500W
 Rated 1300W
 Frequency 50Hz
 Voltage 220V

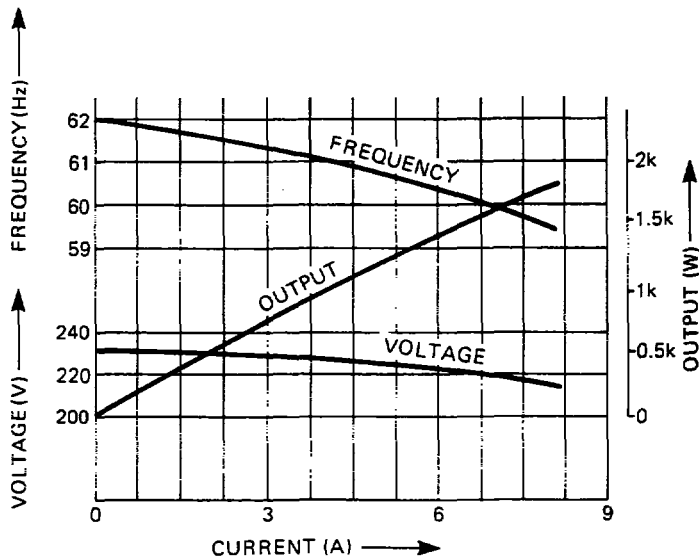

RGX1800

Output Max. 1800W
 Rated 1500W
 Frequency 60Hz
 Voltage 220V

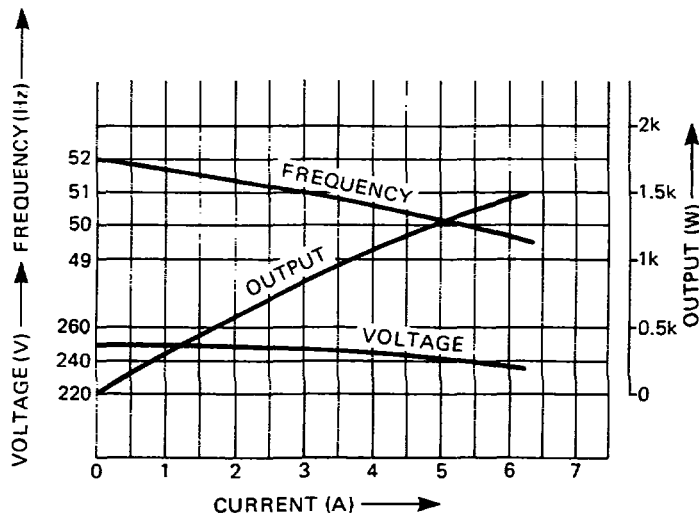

RGX1800

Output Max. 1500W
 Rated 1300W
 Frequency 50Hz
 Voltage 240V

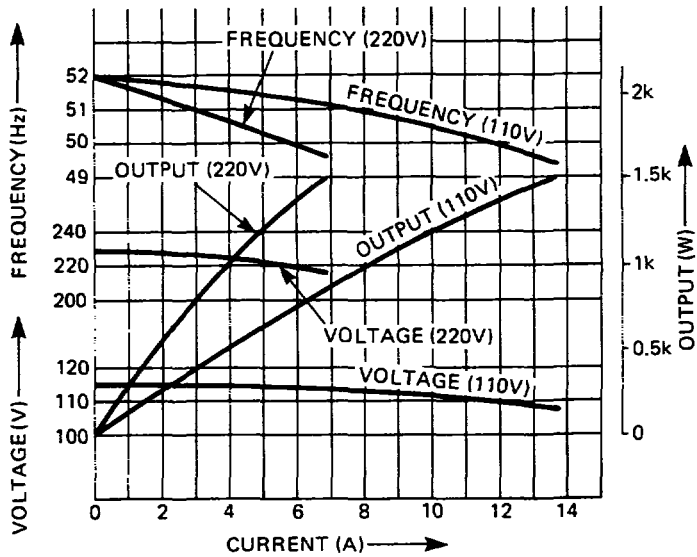

RGX1800

Output Max. 1500W
 Rated 1300W
 Frequency 50Hz
 Voltage 110V/220V

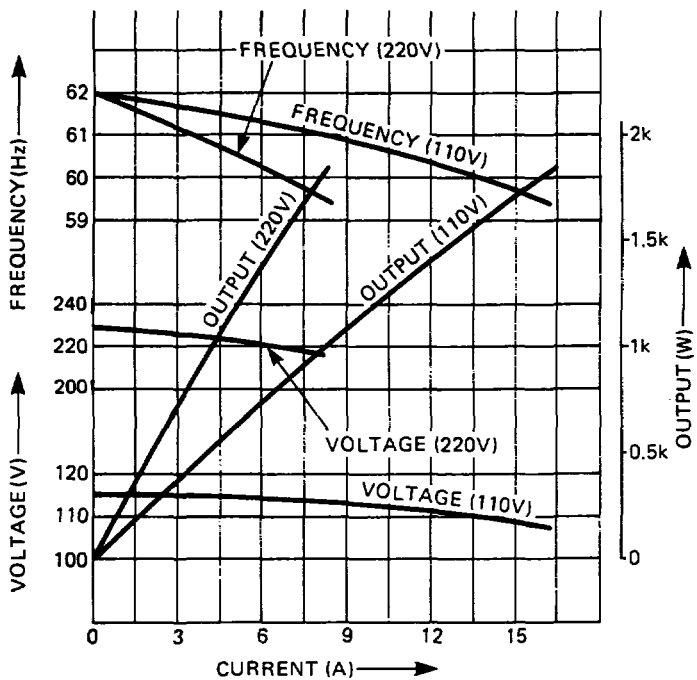

RGX1800

Output Max. 1800W
 Rated 1500W
 Frequency 60Hz
 Voltage 110V/220V

2-2 MODEL RGX2400

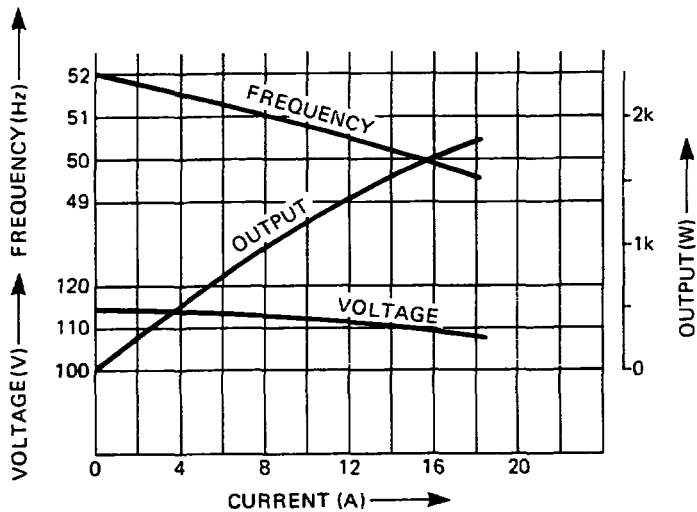

RGX2400

Output Max. 2000W
 Rated 1700W
 Frequency 50Hz
 Voltage 110V

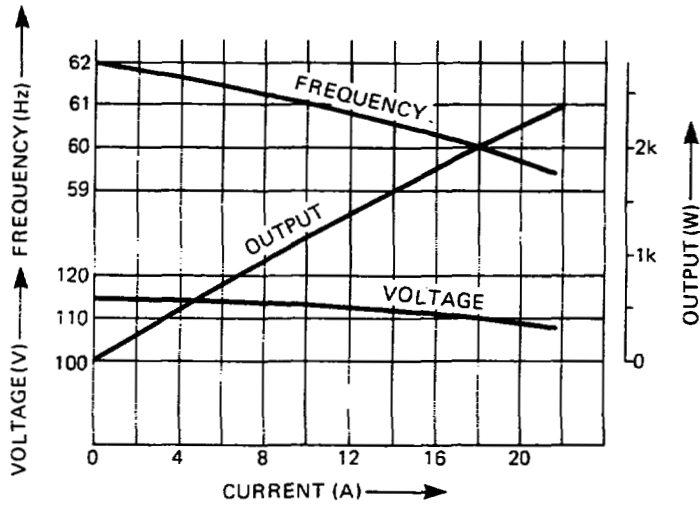

RGX2400

Output Max. 2400W
 Rated 2000W
 Frequency 60Hz
 Voltage 110V

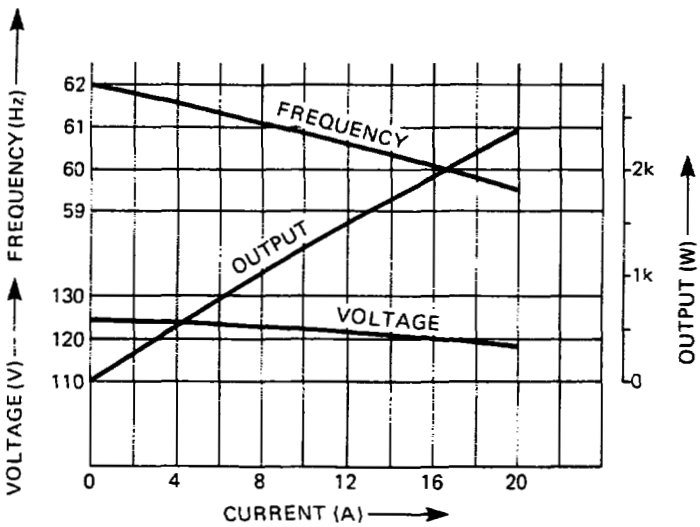

RGX2400

Output Max. 2400W
 Rated 2000W
 Frequency 60Hz
 Voltage 120V

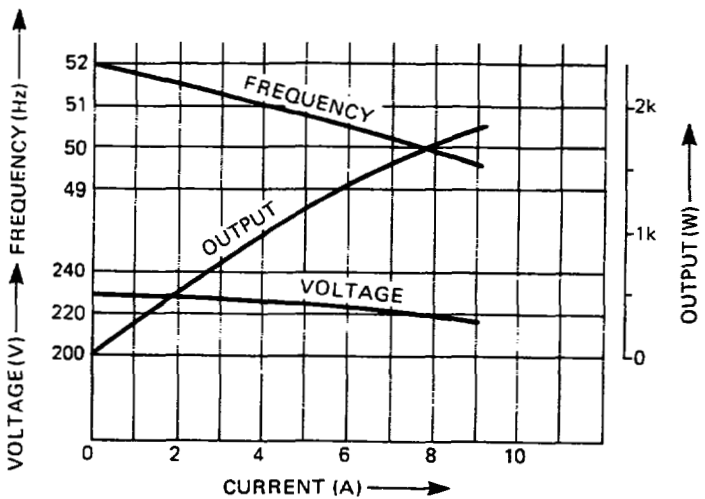

RGX2400

Output Max. 2400W
 Rated 2000W
 Frequency 50Hz
 Voltage 220V

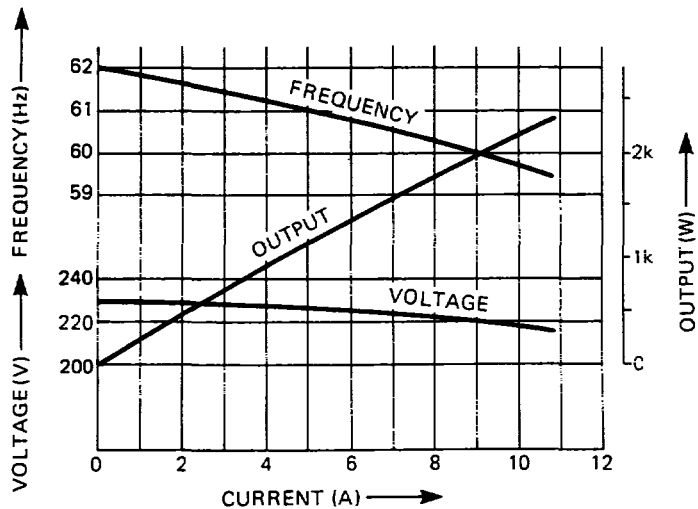

RGX2400

Output Max. 2400W
 Rated 2000W
 Frequency 60Hz
 Voltage 220V

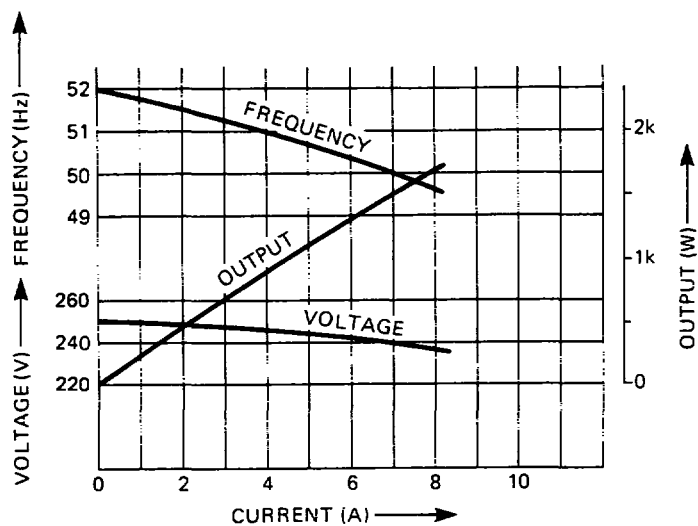

RGX2400

Output Max. 2000W
 Rated 1700W
 Frequency 50Hz
 Voltage 240V

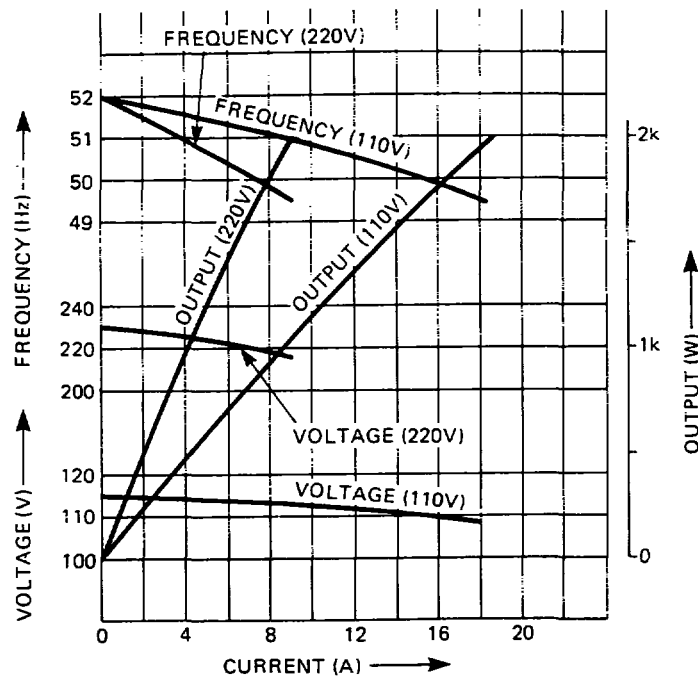

RGX2400

Output Max. 2000W
 Rated 1700W
 Frequency 50Hz
 Voltage 110V/220V

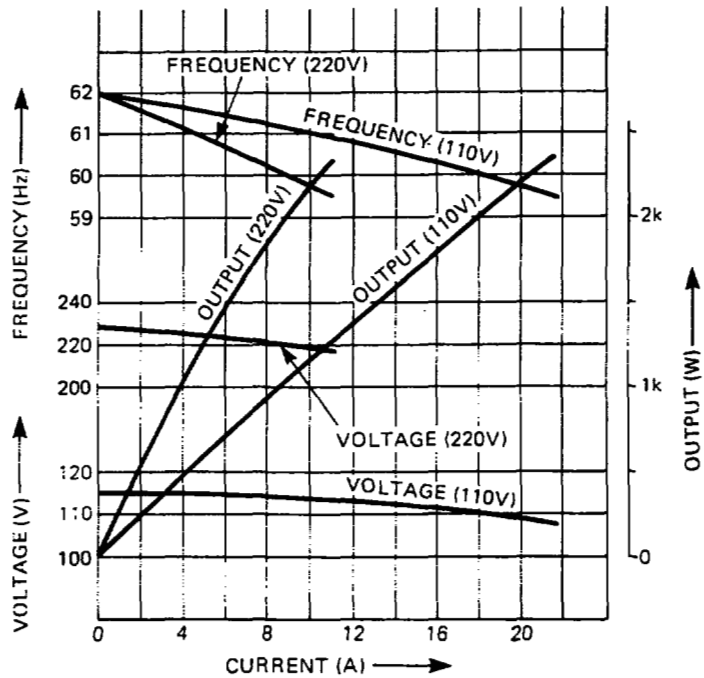

RGX2400

Output Max. 2400W
 Rated 2000W
 Frequency 60Hz
 Voltage 110V/220V

2-3 MODEL RGX3500

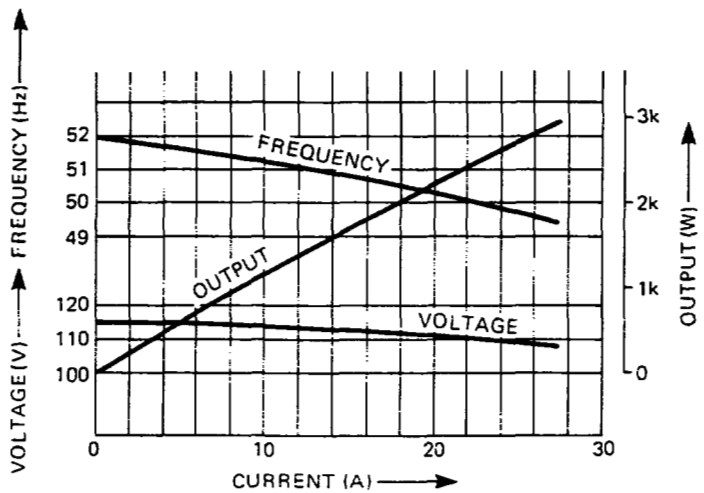

RGX3500

Output Max. 3000W
 Rated 2500W
 Frequency 50Hz
 Voltage 110V

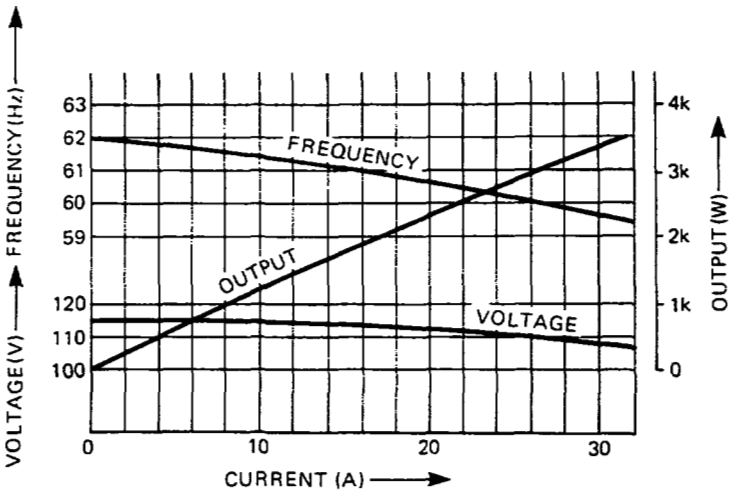

RGX3500

Output Max. 3500W
 Rated 3000W
 Frequency 60Hz
 Voltage 110V

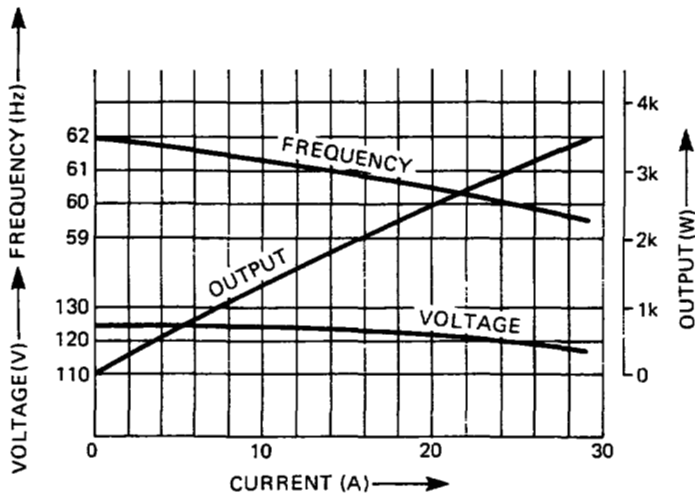

RGX3500

Output Max. 3500W
 Rated 3000W
 Frequency 60Hz
 Voltage 120V

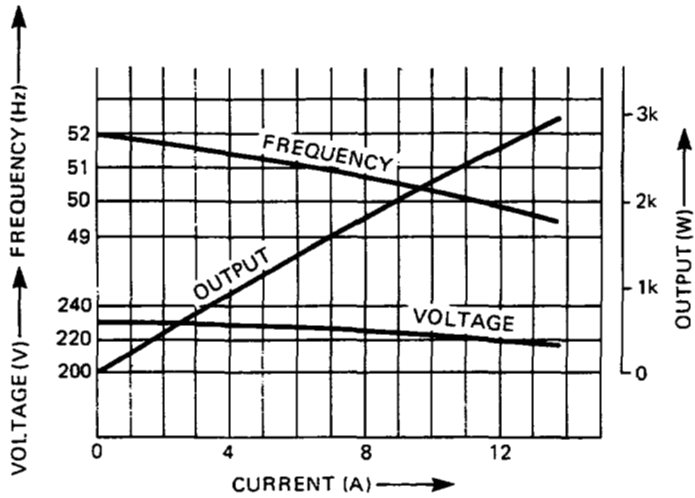

RGX3500

Output Max. 3000W
 Rated 2500W
 Frequency 50Hz
 Voltage 220V

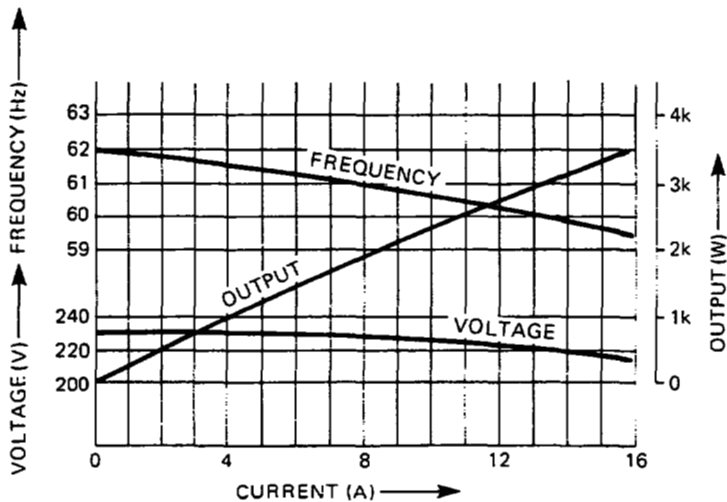

RGX3500

Output Max. 3500W
 Rated 3000W
 Frequency 60Hz
 Voltage 220V

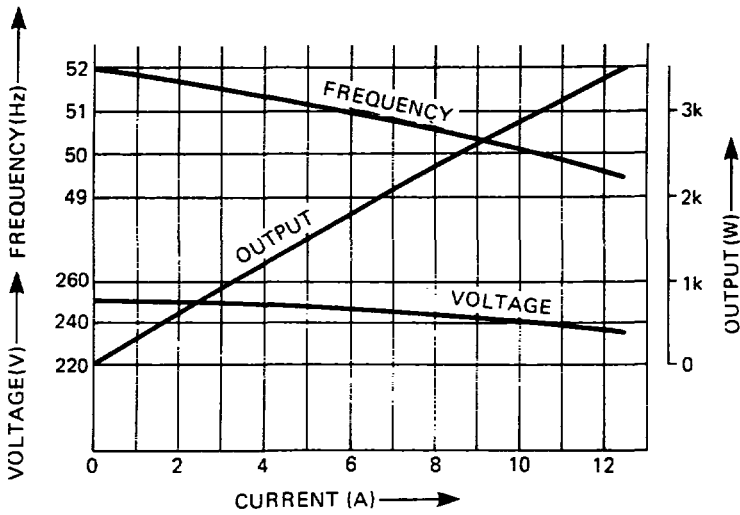

RGX3500

Output Max. 3000W
 Rated 2500W
 Frequency 50Hz
 Voltage 240V

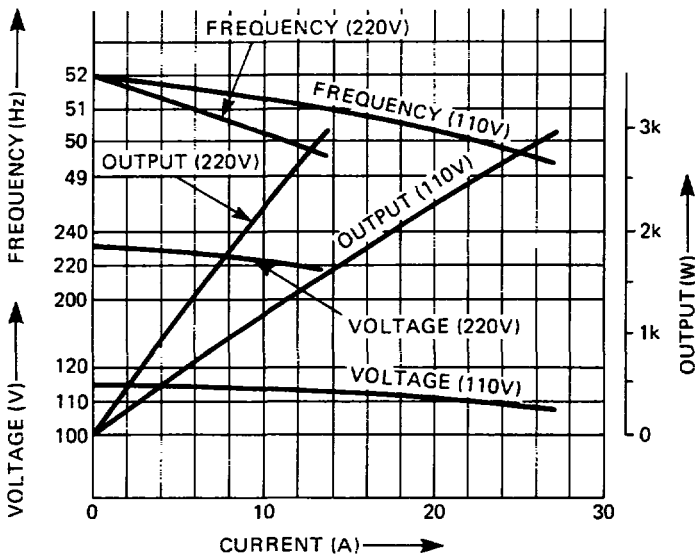

RGX3500

Output Max. 3500W
 Rated 3000W
 Frequency 50Hz
 Voltage 110V/220V

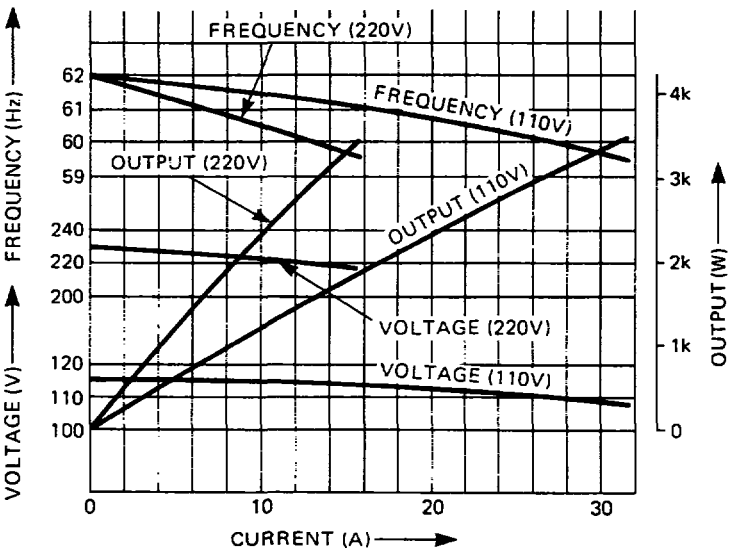

RGX3500

Output Max. 3500W
 Rated 3000W
 Frequency 60Hz
 Voltage 110V/220V

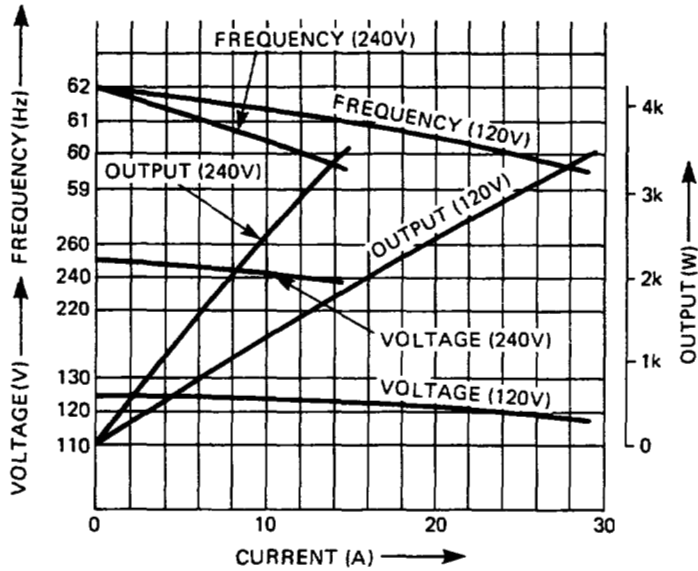

RGX3500

Output Max. 3500W
 Rated 3000W
 Frequency 60Hz
 Voltage 120V/240V

2-4 MODEL RGX5500

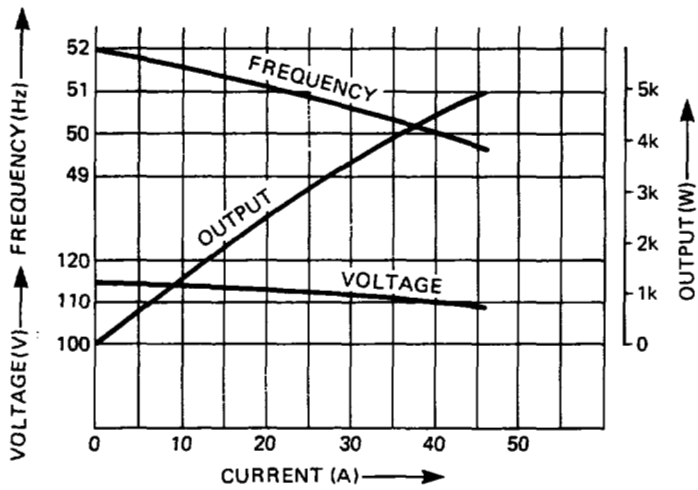

RGX5500

Output Max. 5000W
 Rated 4400W
 Frequency 50Hz
 Voltage 110V

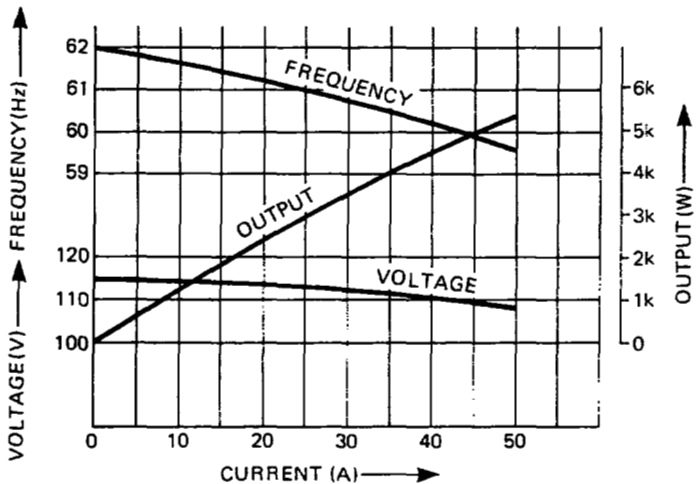

RGX5500

Output Max. 5500W
 Rated 4800W
 Frequency 60Hz
 Voltage 110V

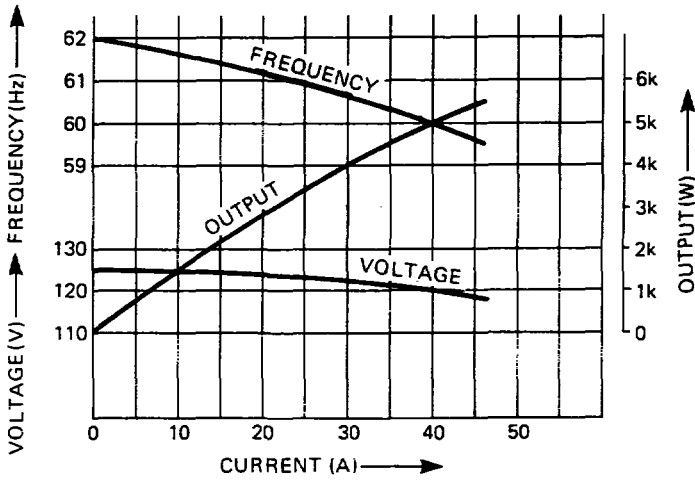

RGX5500

Output Max. 5000W
 Rated 4800W
 Frequency 60Hz
 Voltage 120V

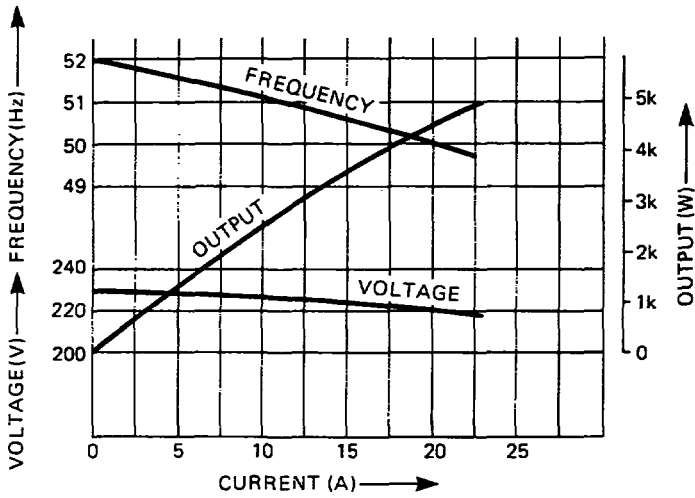

RGX5500

Output Max. 5000W
 Rated 4400W
 Frequency 50Hz
 Voltage 220V

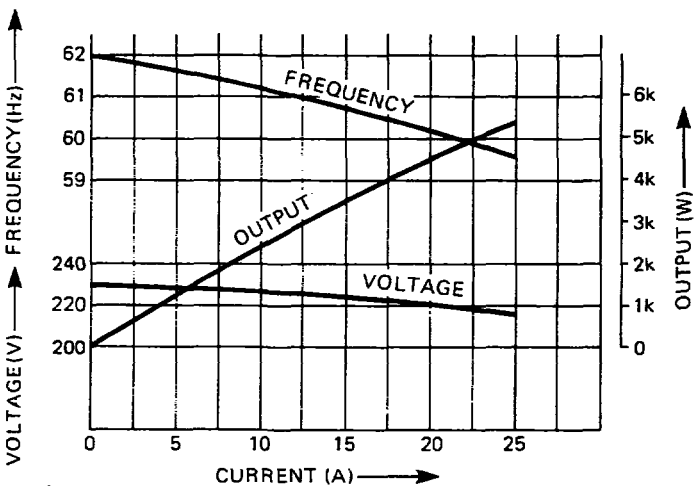

RGX5500

Output Max. 5500W
 Rated 4800W
 Frequency 60Hz
 Voltage 220V

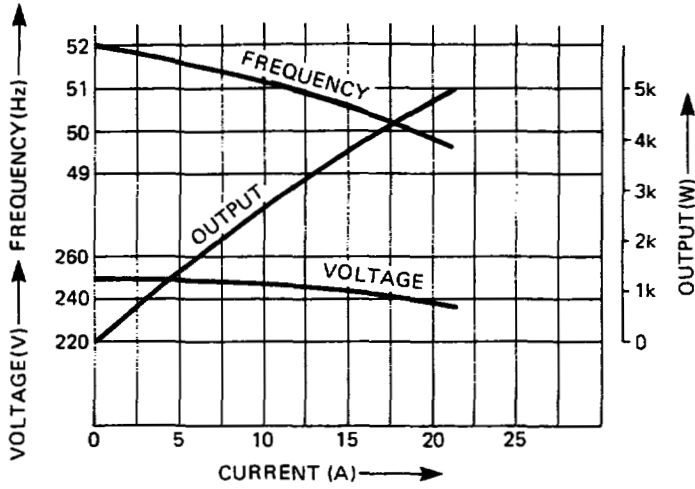

RGX5500

Output Max. 5000W
 Rated 4400W
 Frequency 50Hz
 Voltage 240V

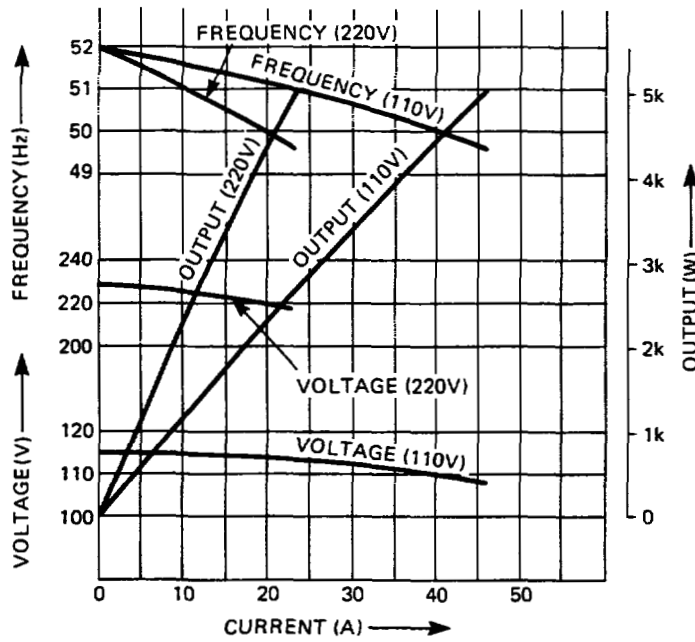

RGX5500

Output Max. 5000W
 Rated 4400W
 Frequency 50Hz
 Voltage 110V/220V

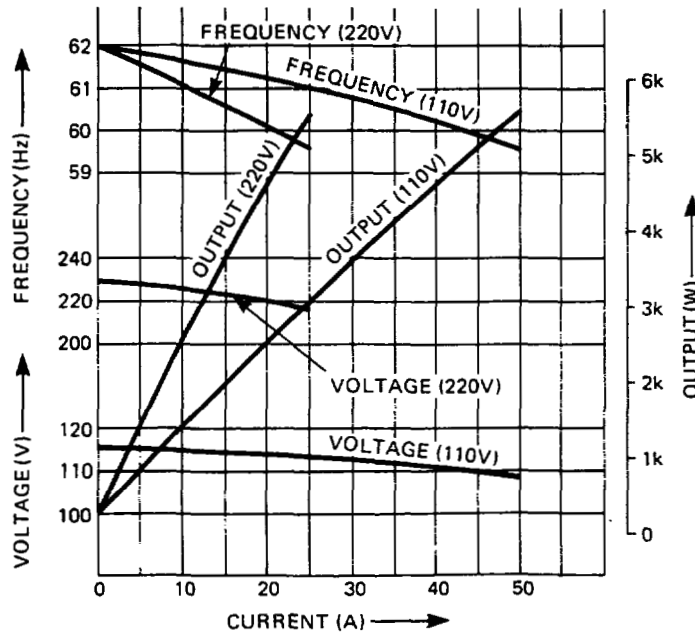

RGX5500

Output Max. 5500W
 Rated 4800W
 Frequency 60Hz
 Voltage 110V/220V

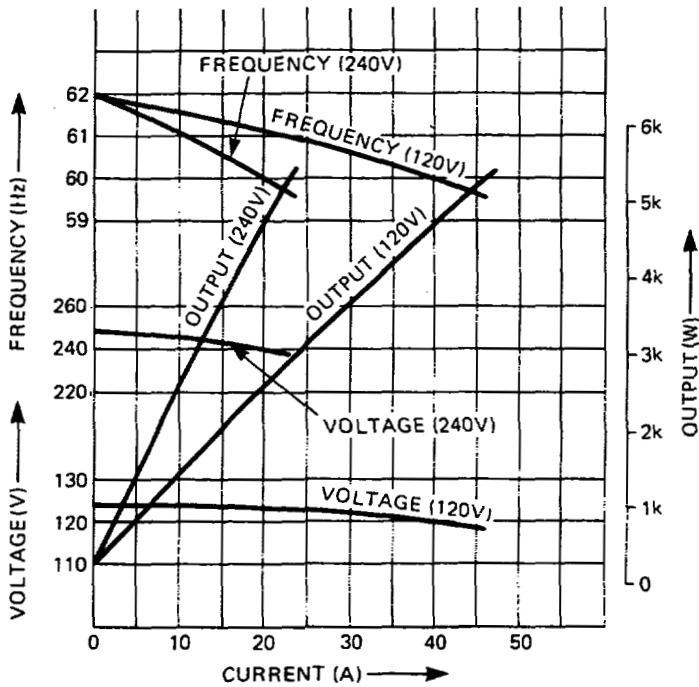

RGX5500

Output Max. 5500W
 Rated 4800W
 Frequency 60Hz
 Voltage 120V/240V

2-5 DC OUTPUT

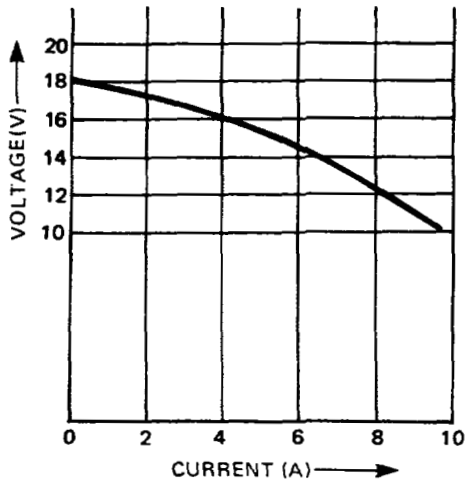

DC Voltage 12V
 DC Ampere 8.3A
 DC output 100W

The voltage curve shown in the left indicates the characteristic of DC output when charging a battery. The voltage may be decreased by 20% when the resistance load is applied.

NOTE: It is possible to use both DC and AC outputs simultaneously up to the rated output in total.

3. FEATURES

3-1 BRUSHLESS ALTERNATOR

Newly developed brushless alternator eliminates troublesome brush maintenance.

3-2 CONDENSER TYPE VOLTAGE REGULATOR

A trouble free condenser type voltage regulator ensures a stable voltage under all working conditions.

3-3 OIL SENSOR

Oil sensor automatically shuts off the engine whenever the oil level falls down below the lower limit to protect the engine from seizure.

3-4 QUIET OPERATION

Robin RGX series generator delivers a quiet operation with :

- A large super silent muffler.
- A quiet 4-stroke Robin engine.
- A silent cyclone air cleaner.

3-5 NO RADIO NOISE

Noise suppressor spark plug and spark plug cap are equipped standard to prevent radio frequency interference.

3-6 LARGE FUEL TANK

The large fuel tank allows more than 5 to 10 hours of continuous operation which is sufficient for a half day or one day work without refueling.

3-7 RUGGED TUBULAR FRAME

Full cradle type rugged tubular frame protects the generator all around.

3-8 COMPACT AND LIGHT WEIGHT

Newly developed brushless alternator enabled the RGX generators to be very compact in size and light in weight.

3-9 MINIMAL MAINTENANCE

- A brushless alternator release the operator from periodical brush maintenance.
- A trouble free condenser type voltage regulator.
- A drip-proof alternator design.
- No-fuse circuit breakers.
- An electronic pointless ignition system.
- A dust-proof cyclone air cleaner.

3-10 LONG-LIFE DURABILITY

The heav-duty 4 stroke Robin engine and virtually maintenance-free brushless alternator ensure greater durability with :

- A brushless alternator with a condenser voltage regulator.
- Full rubber mount in a sturdy tubular frame.
- A forged steel crankshaft supported by two main ball bearings.
- A pointless electronic ignition system.
- A cast iron cylinder liner.
- A forged aluminum connecting rod.

4. GENERAL DESCRIPTION OF THE GENERATOR

4-1 EXTERNAL VIEW of GENERATOR

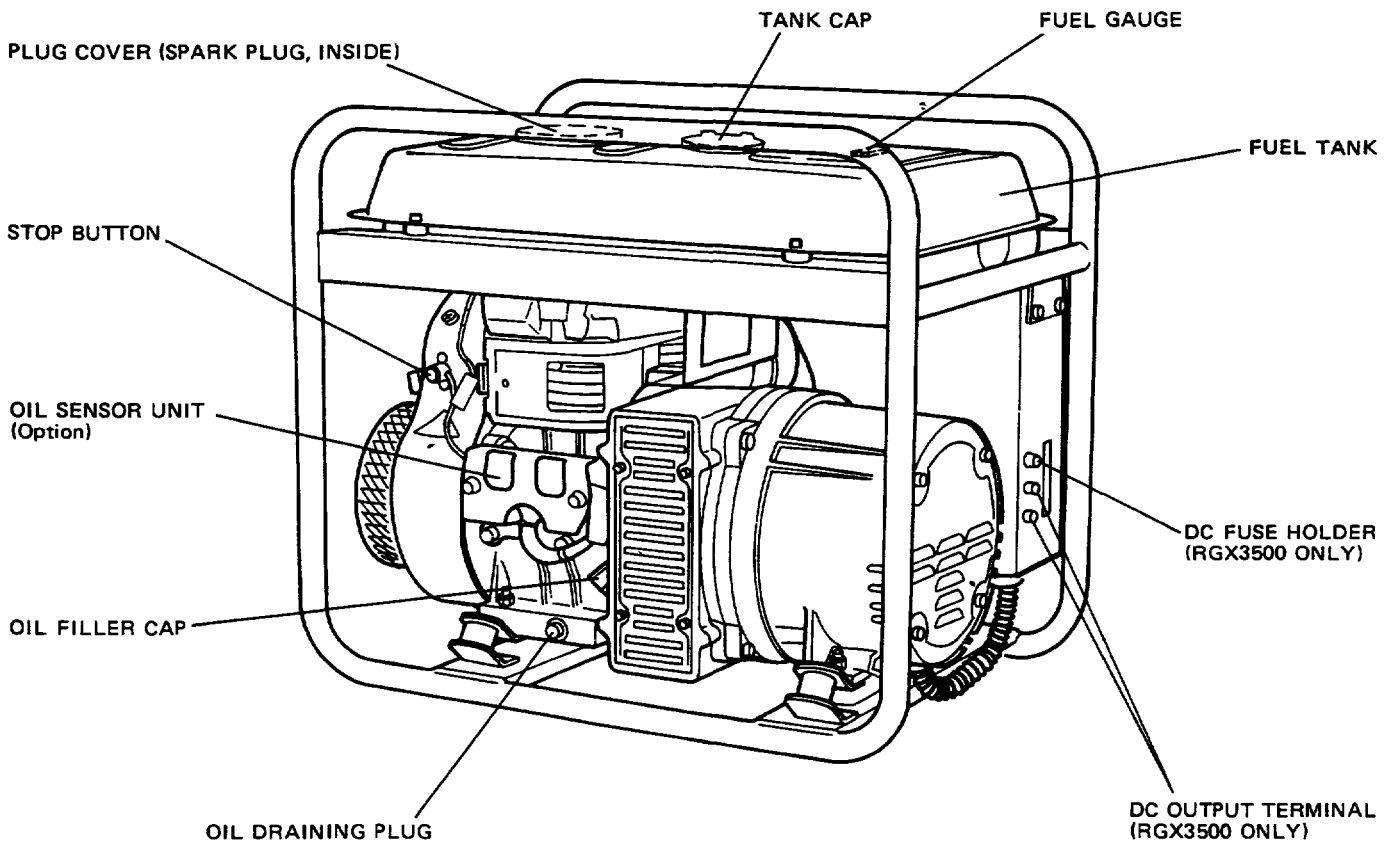
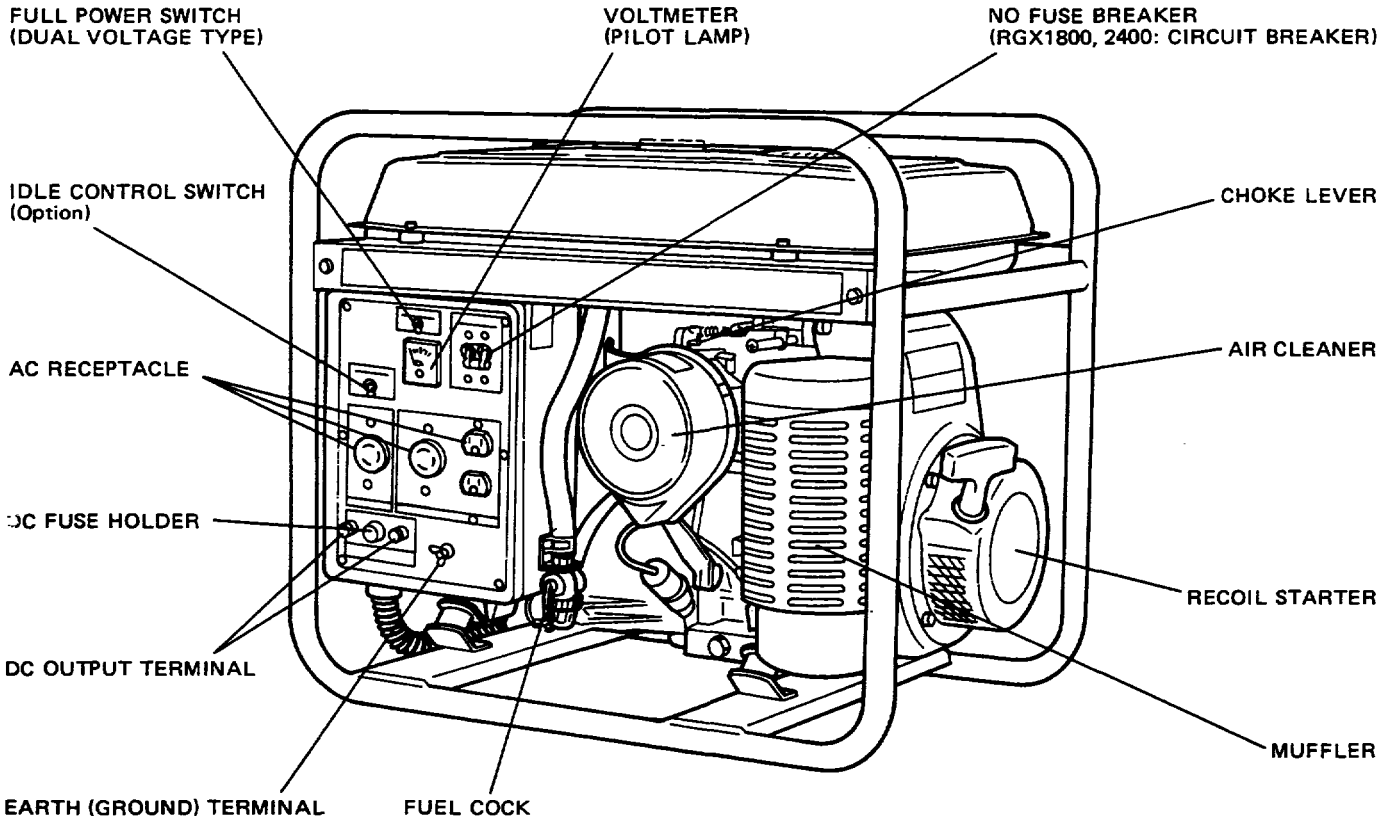

4-2 CONTROL PANEL

● RGX1800 : 50Hz-110V, 60Hz-120V TYPE

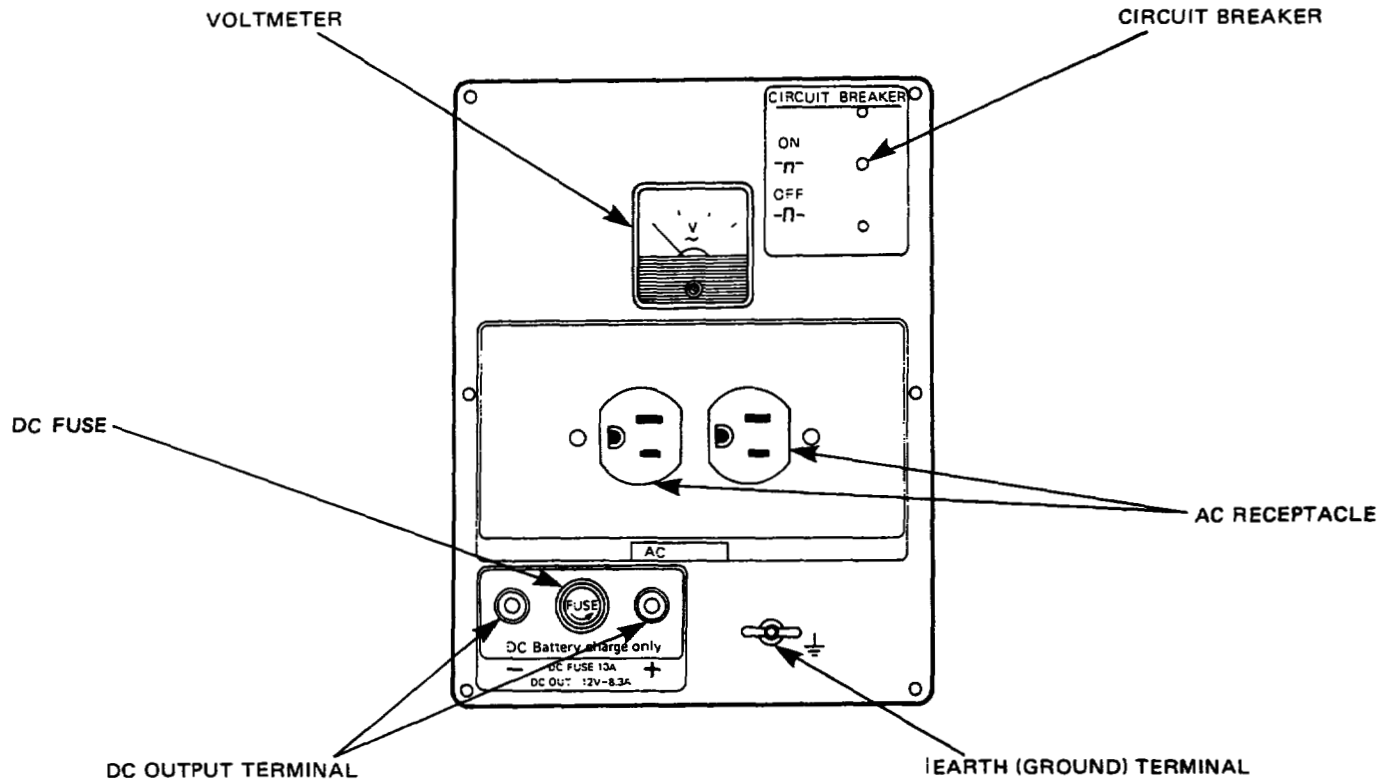

● RGX2400 : 50Hz-110V, 60Hz-120V TYPE

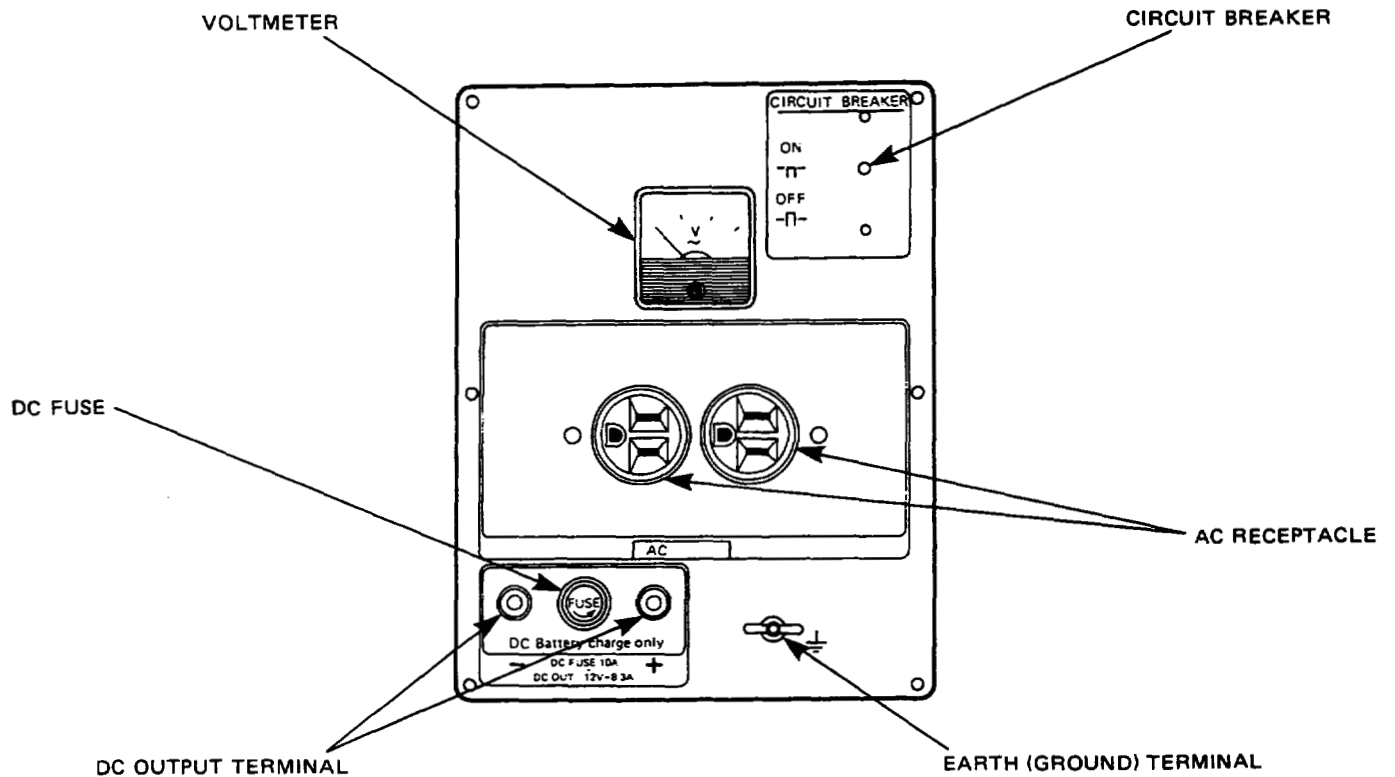

● RGX1800, RGX2400 : 50Hz-220V, 240V, 60Hz-220V TYPE

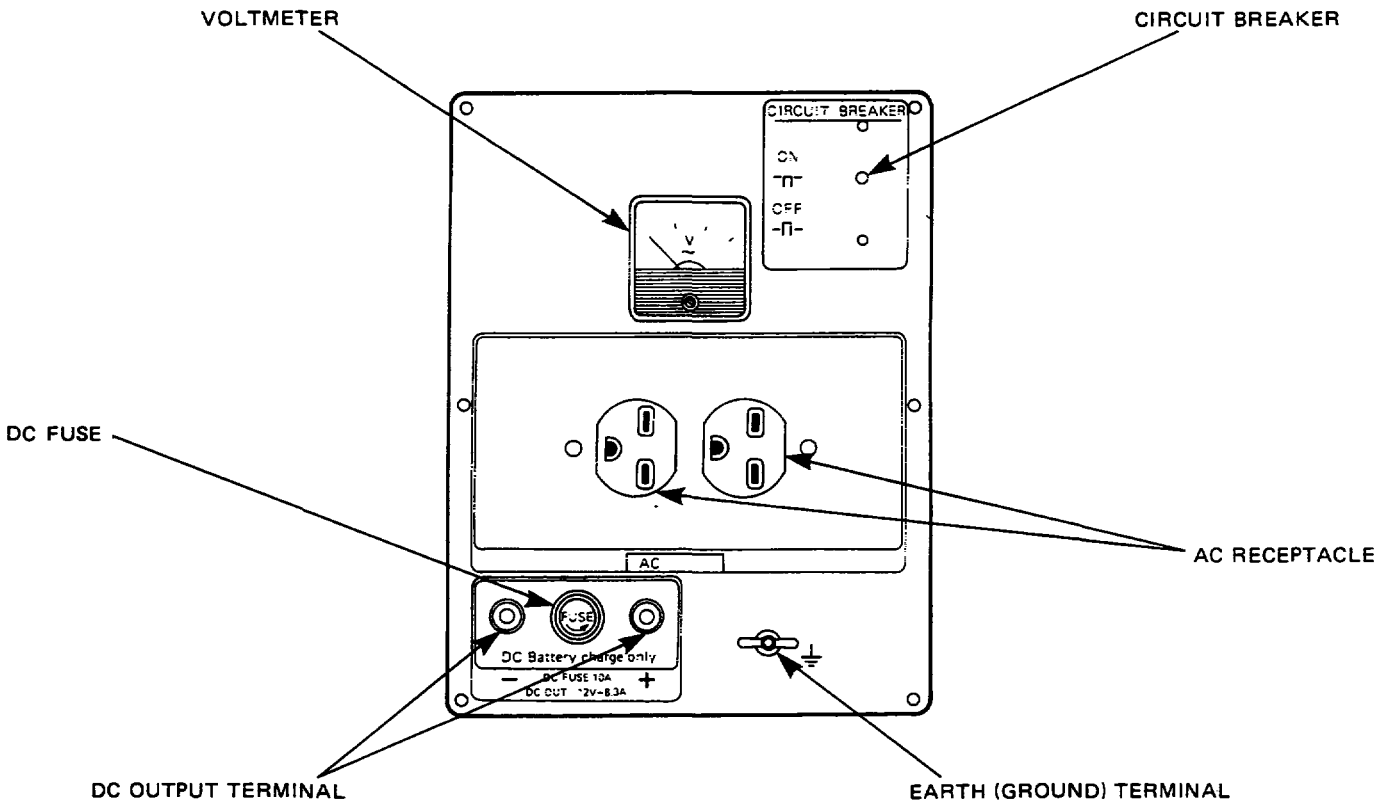

● RGX1800, RGX2400 : 50Hz, 60Hz-110V/220V TYPE

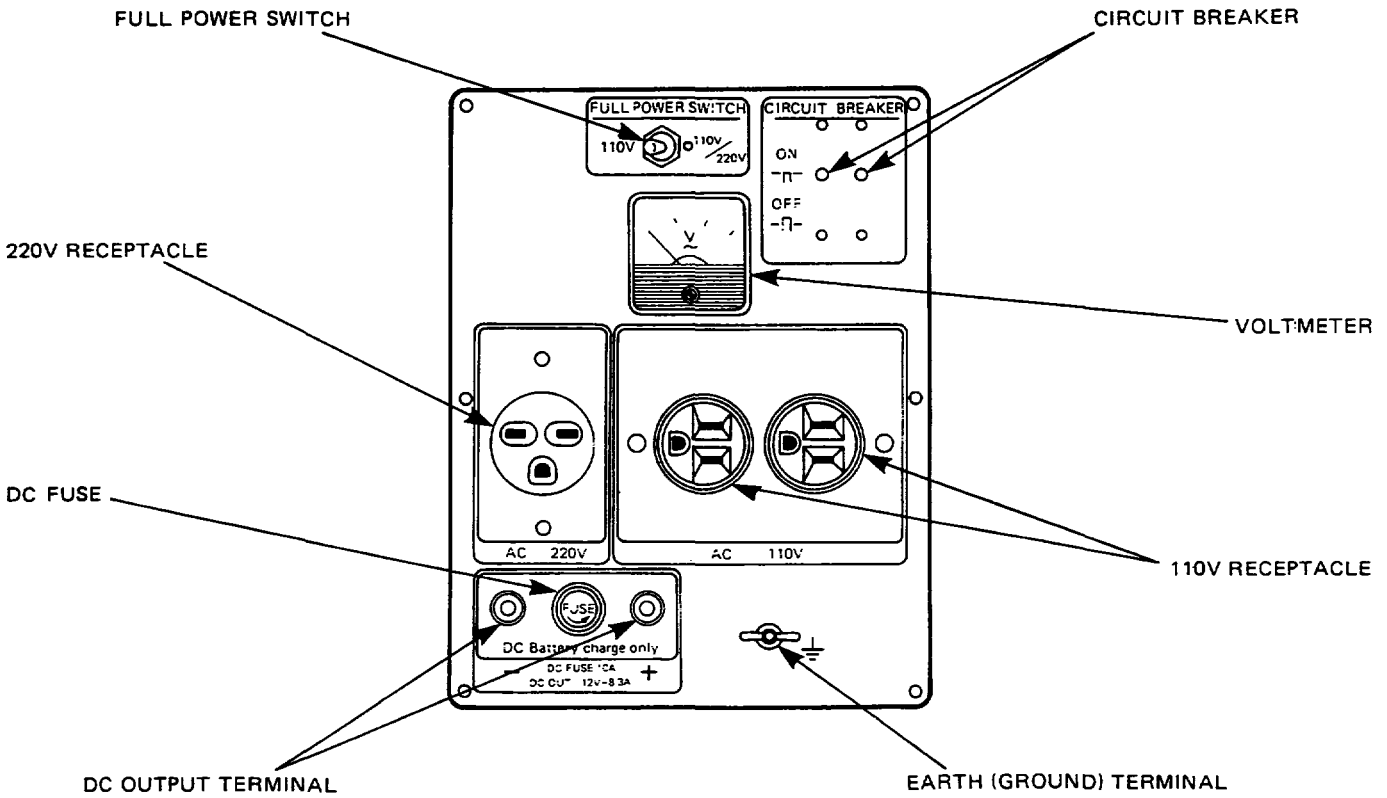

● **RGX1800, 2400 : U.K., 50Hz-110V/120V [BS RECEPTACLE]**

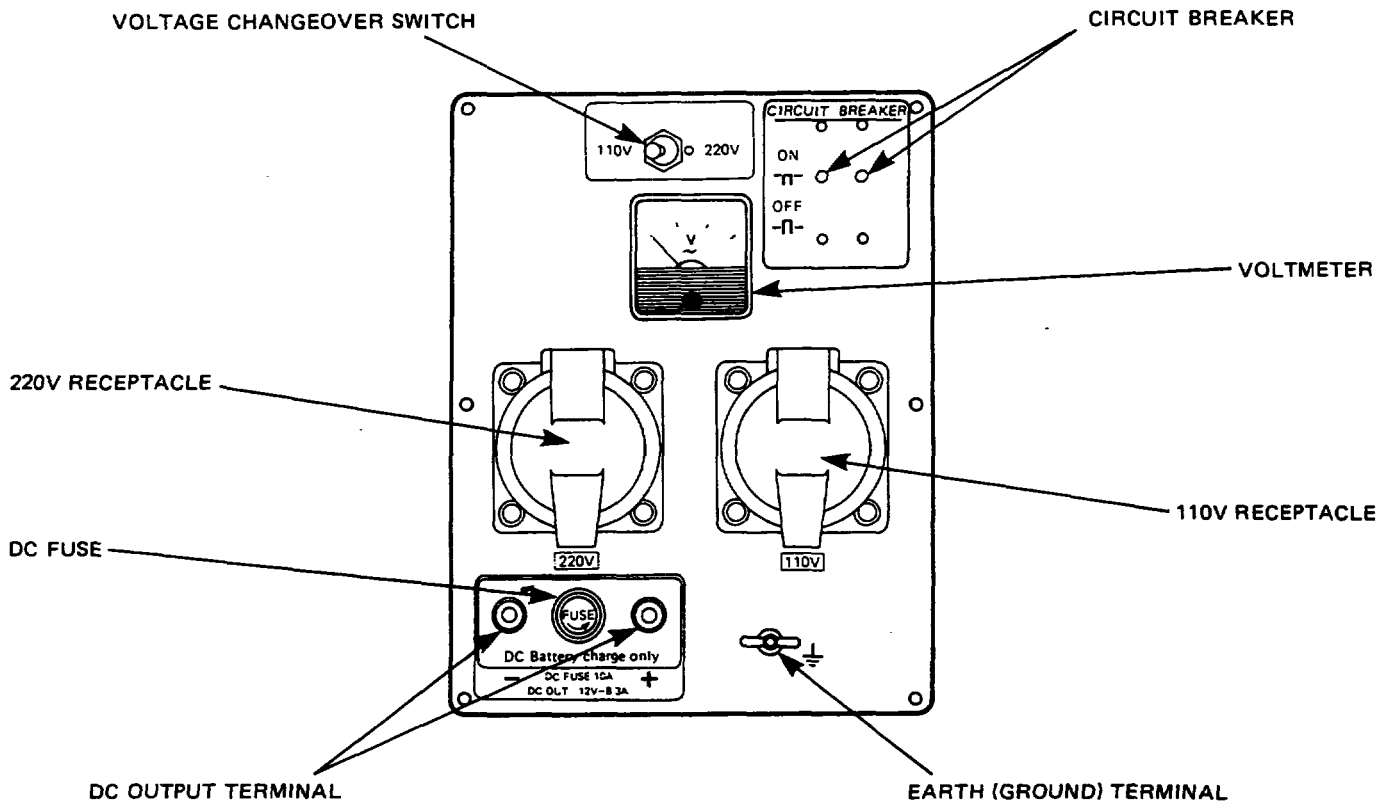

● **RGX2400 : U.S.A., 60Hz-120V [NEMA RECEPTACLE]**

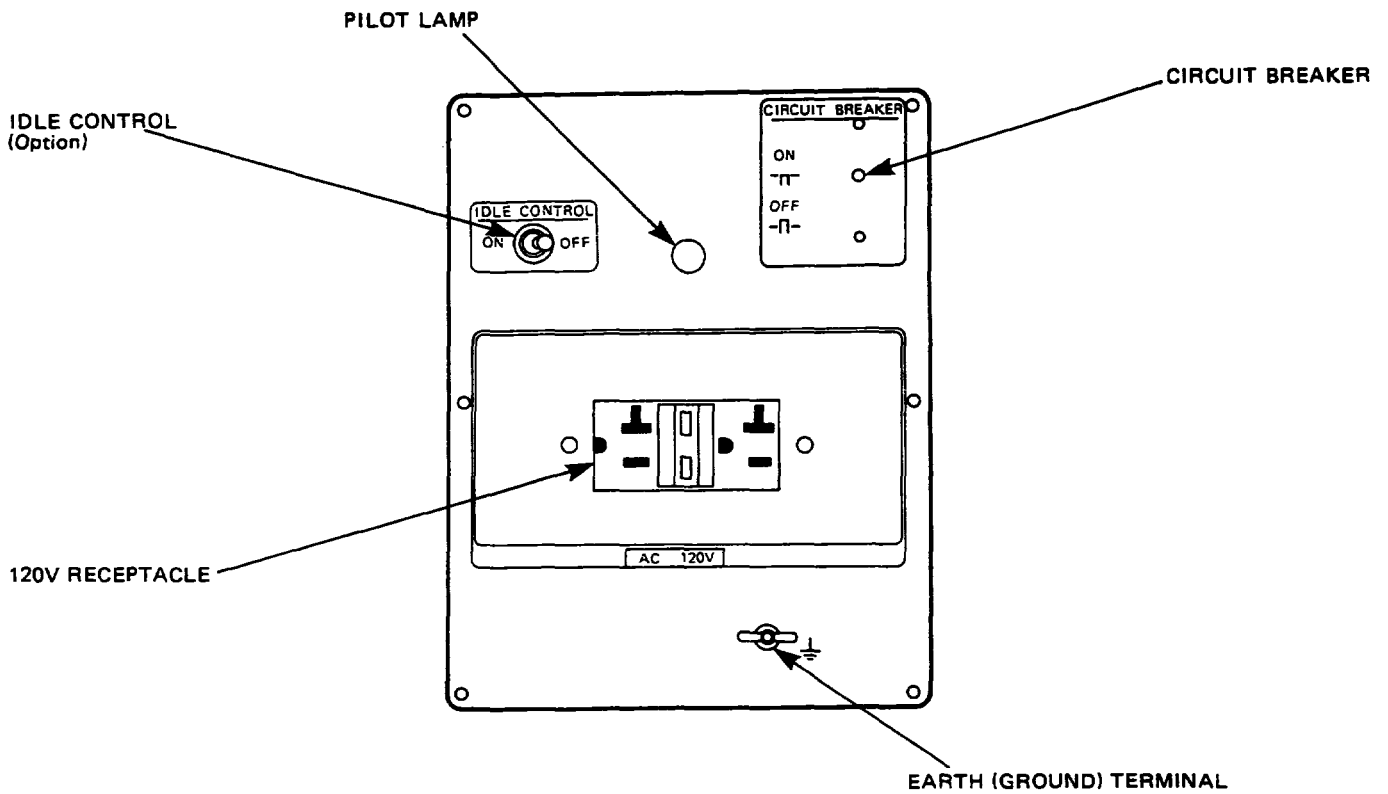

● **RGX1800, 2400 : GERMANY, 50Hz-220V**

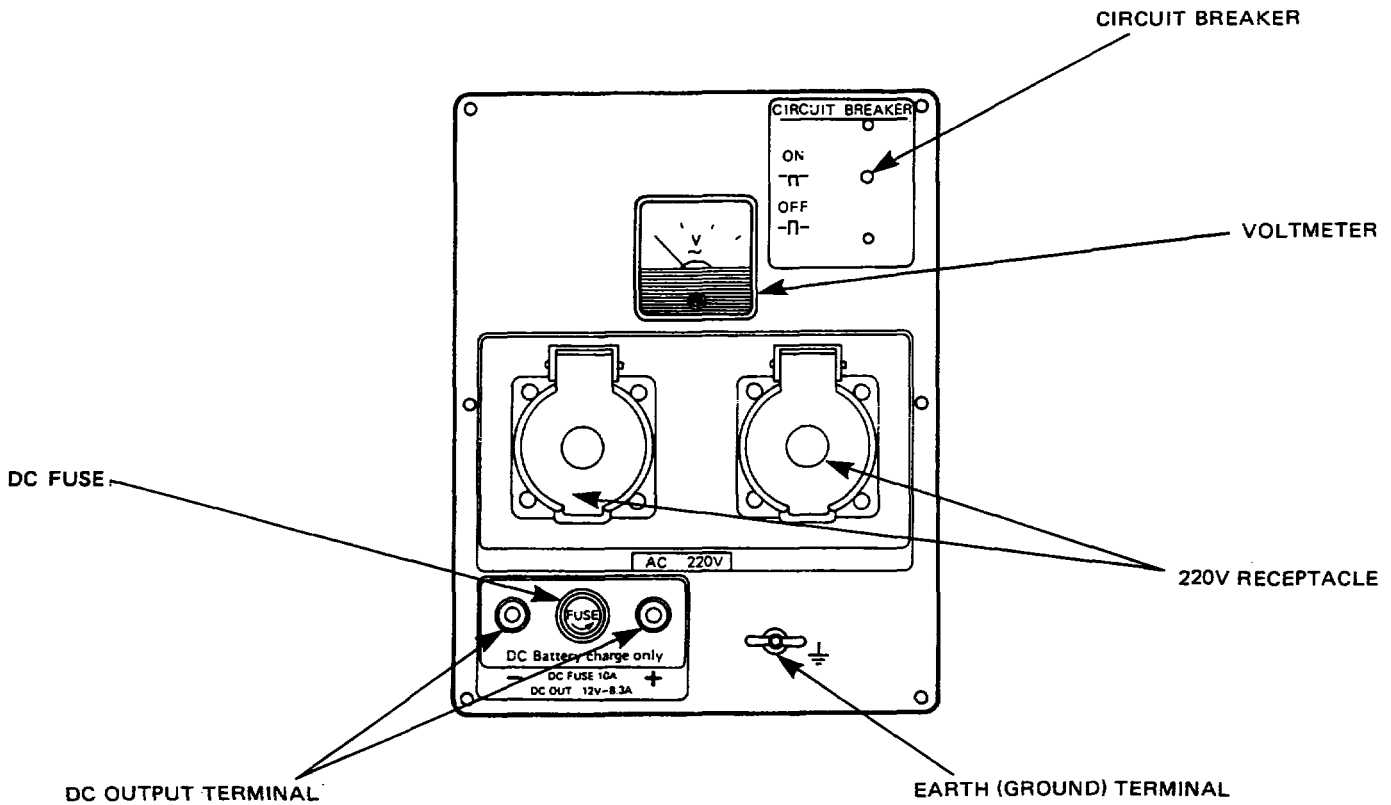

● **RGX1800, 2400 : 50Hz-220V [WITH SPECIAL RECEPTACLE]**

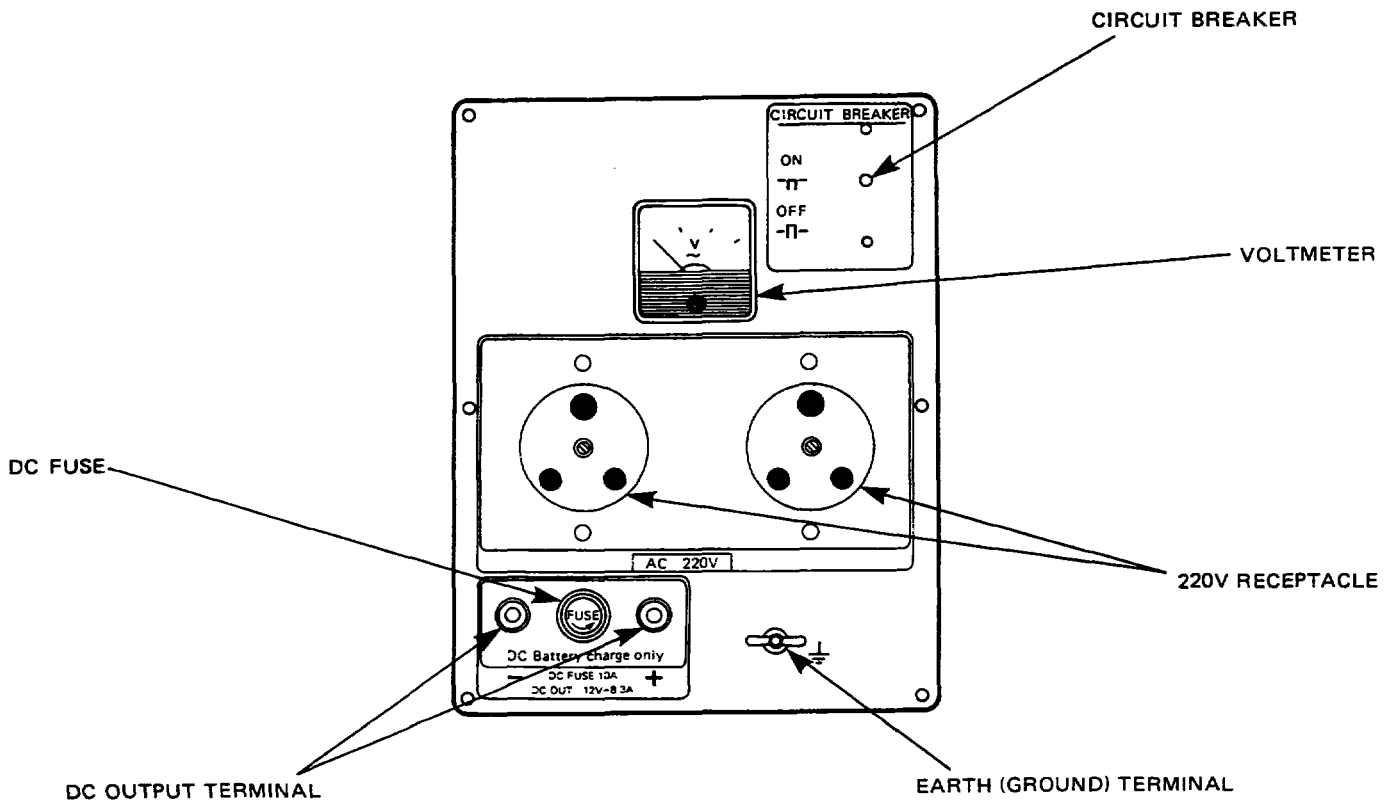

● **RGX1800, 2400 : SWITZERLAND, 50Hz-220V**

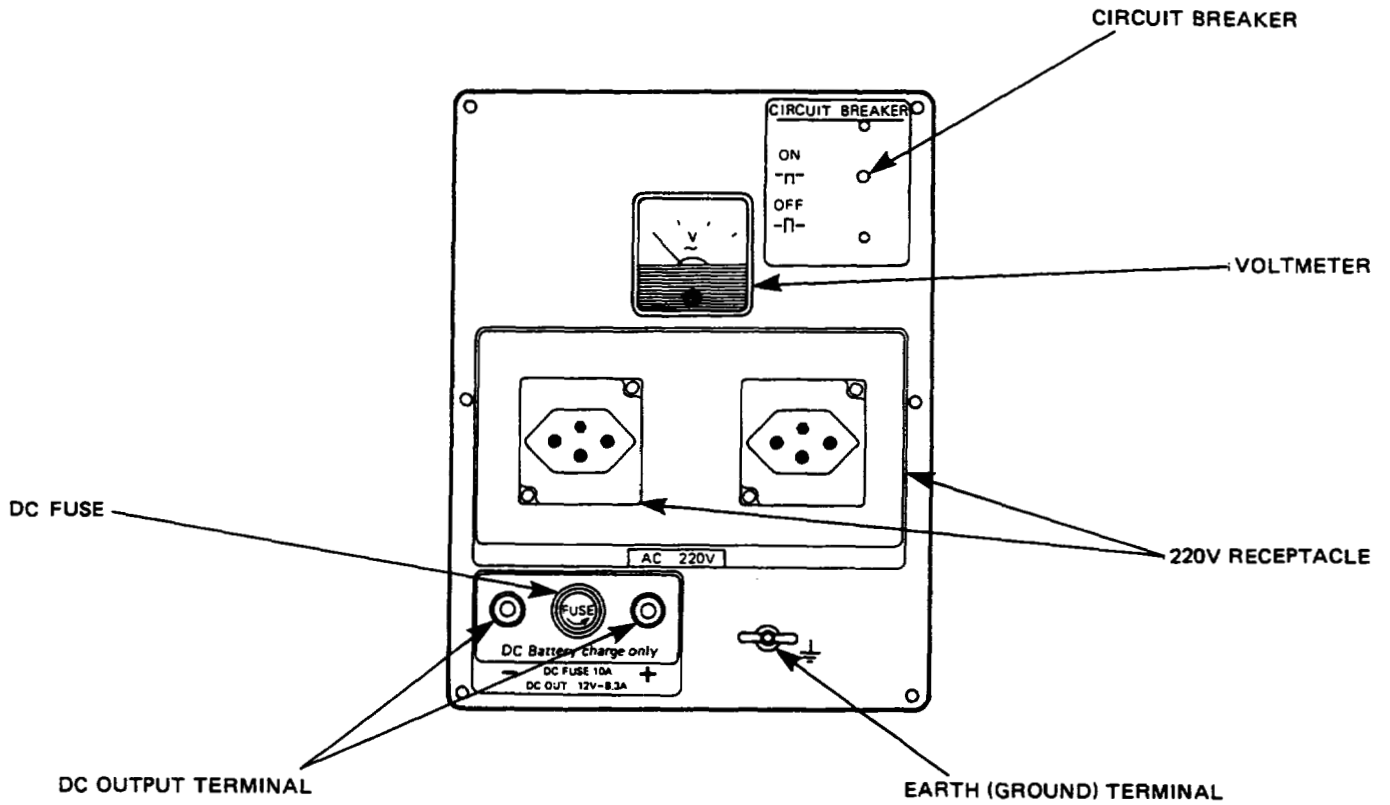

● **RGX1800, 2400 : AUSTRALIA, 50Hz-240V**

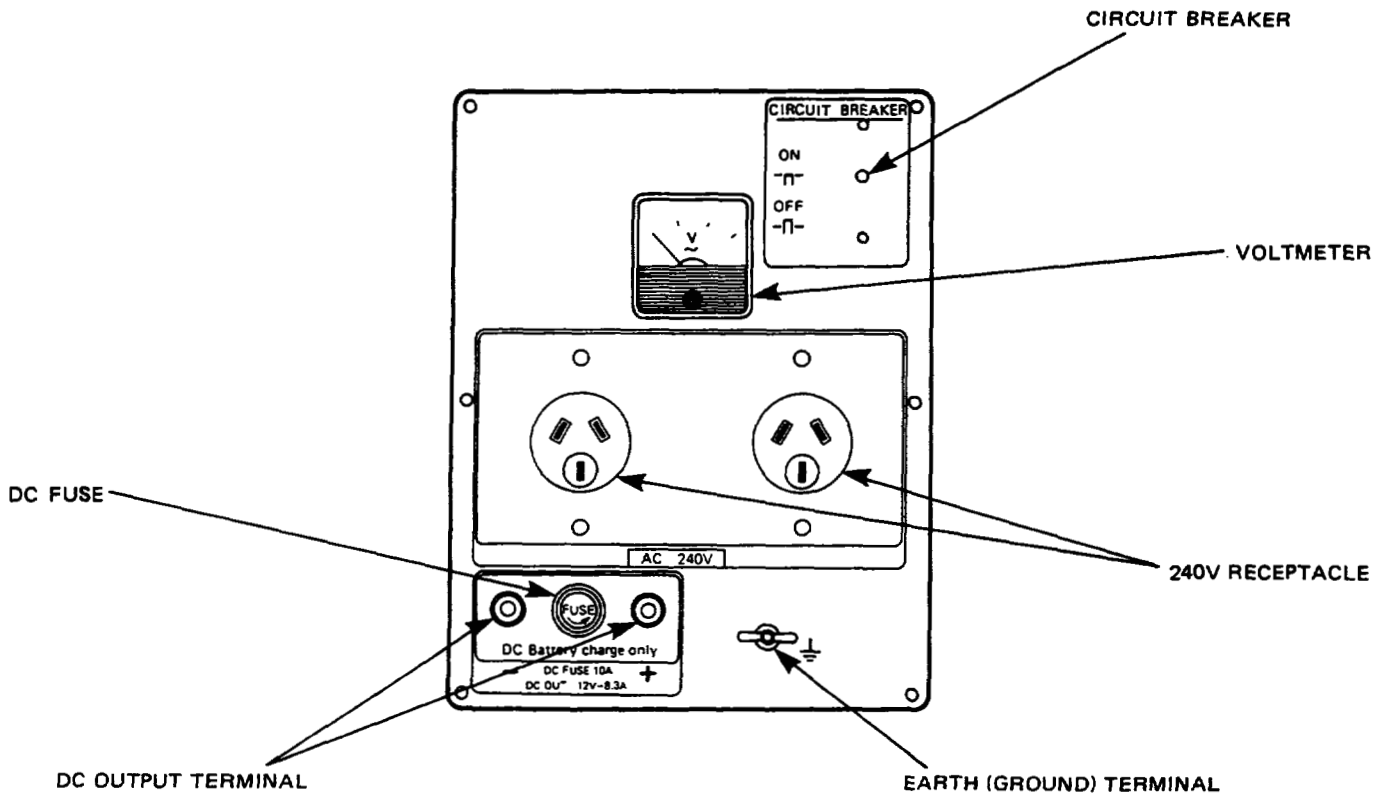

● **RGX3500 : 50Hz-110V, 60Hz-120V TYPE**

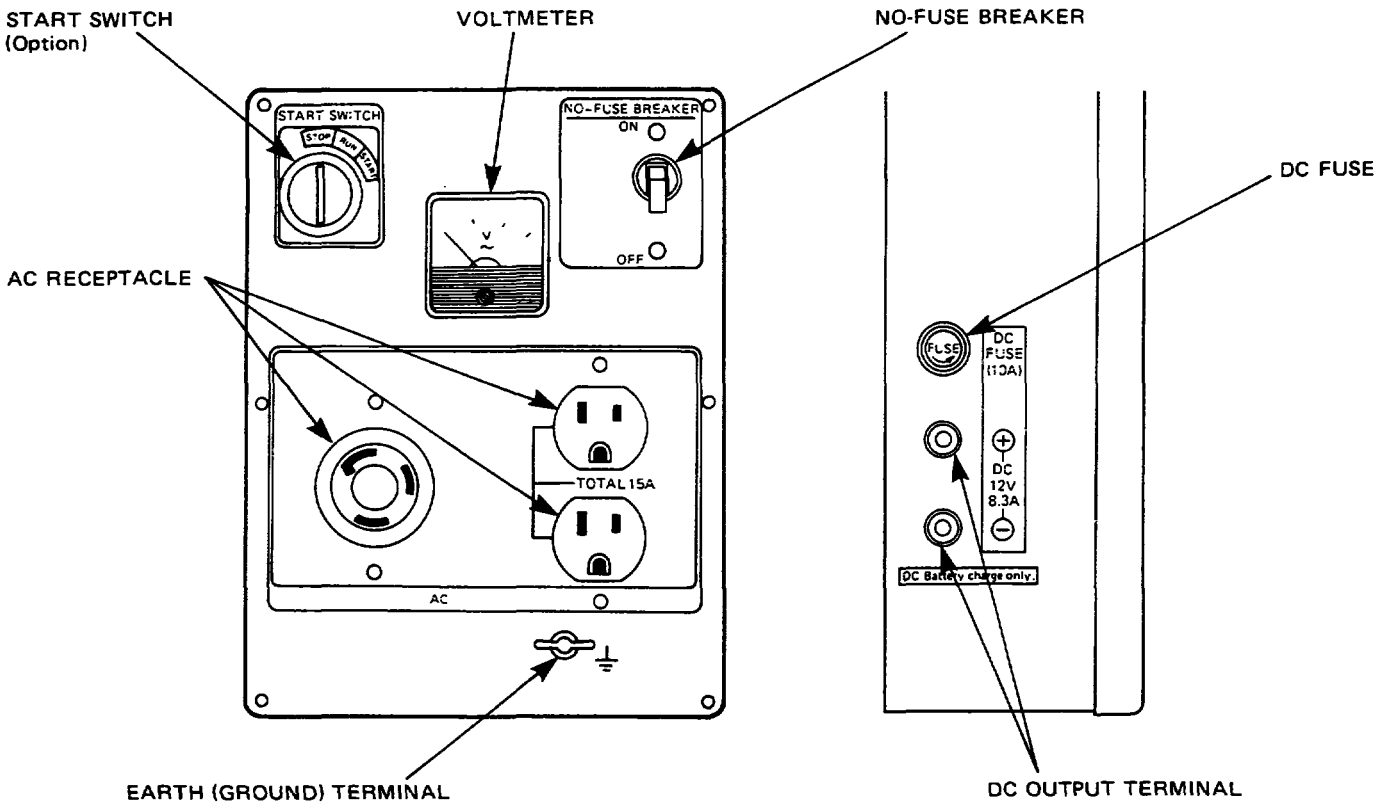

● **RGX3500 : 50Hz-220V, 240V, 60Hz-220V TYPE**

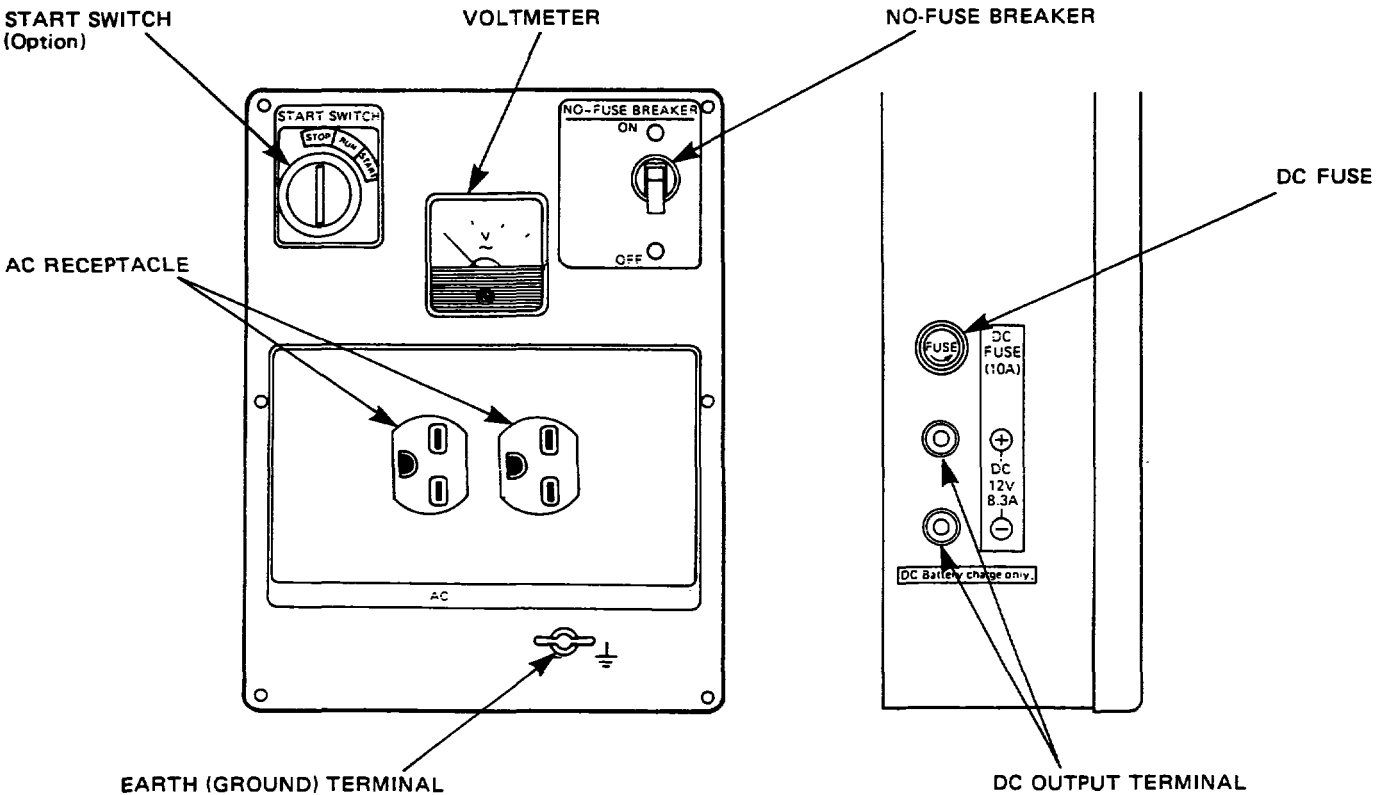

● **RGX3500 : 50Hz, 60Hz-110V/220V TYPE**

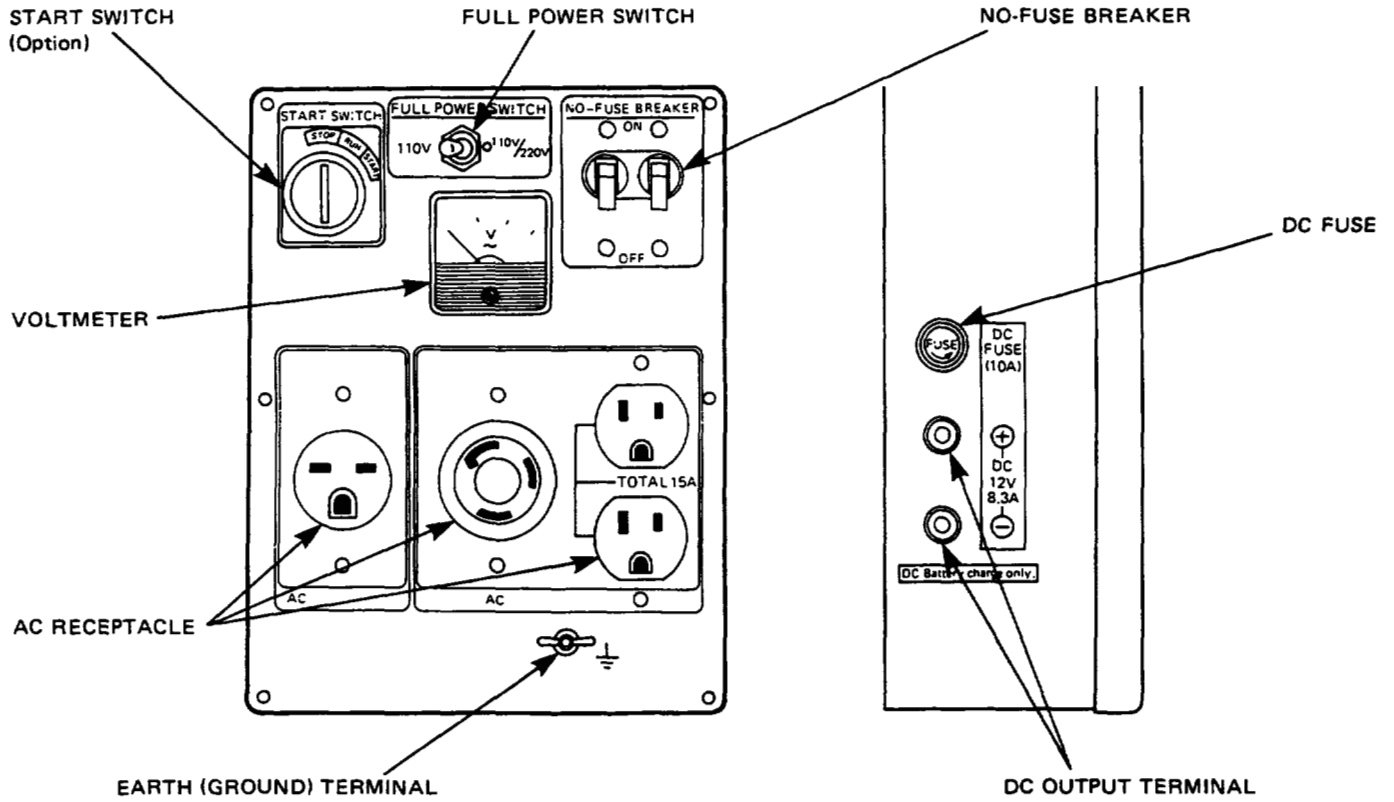

● **RGX3500 : U.K., 50Hz-110V/220V [BS RECEPTACLE]**

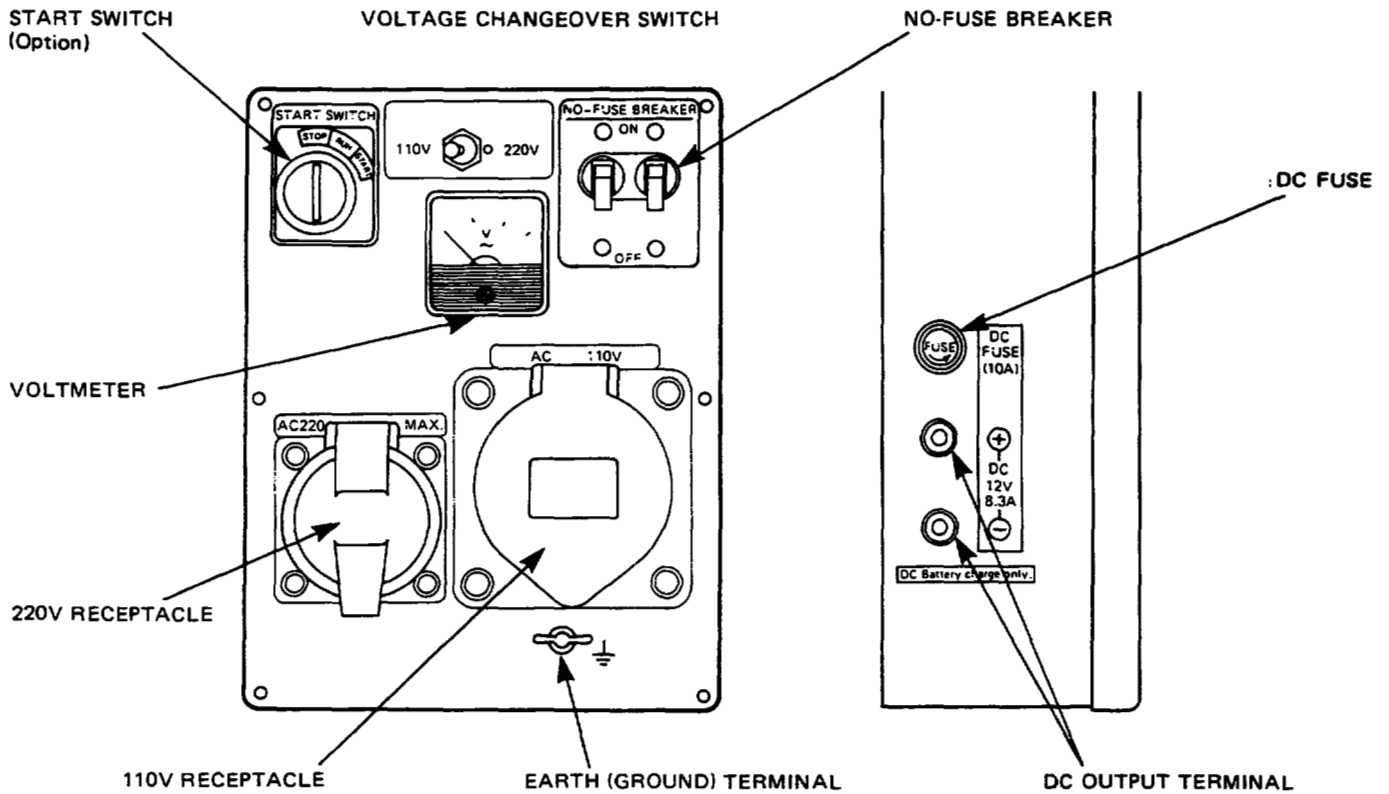

● **RGX3500 : U.S.A., 60Hz-120V/240V [NEMA RECEPTACLE]**

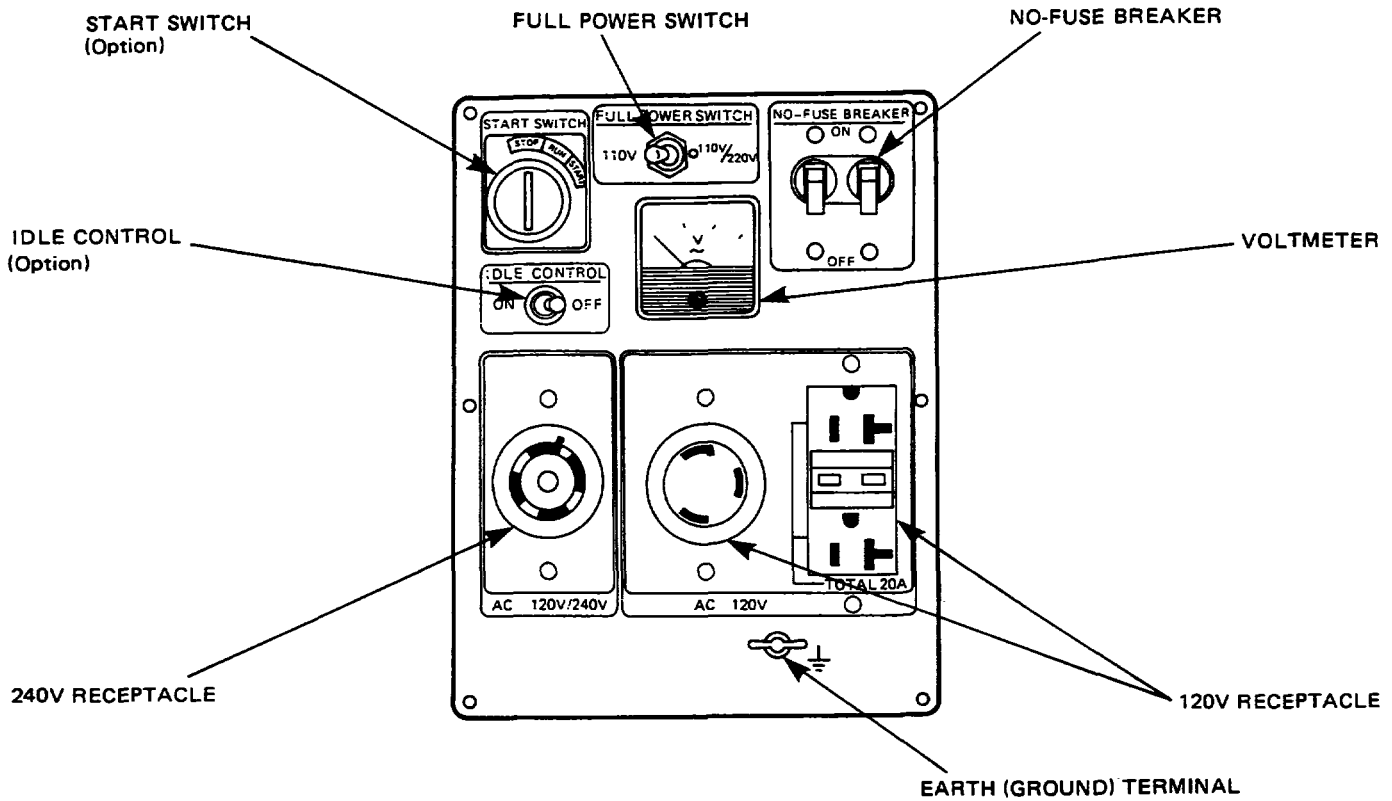

● **RGX3500 : GERMANY, 50Hz-220V**

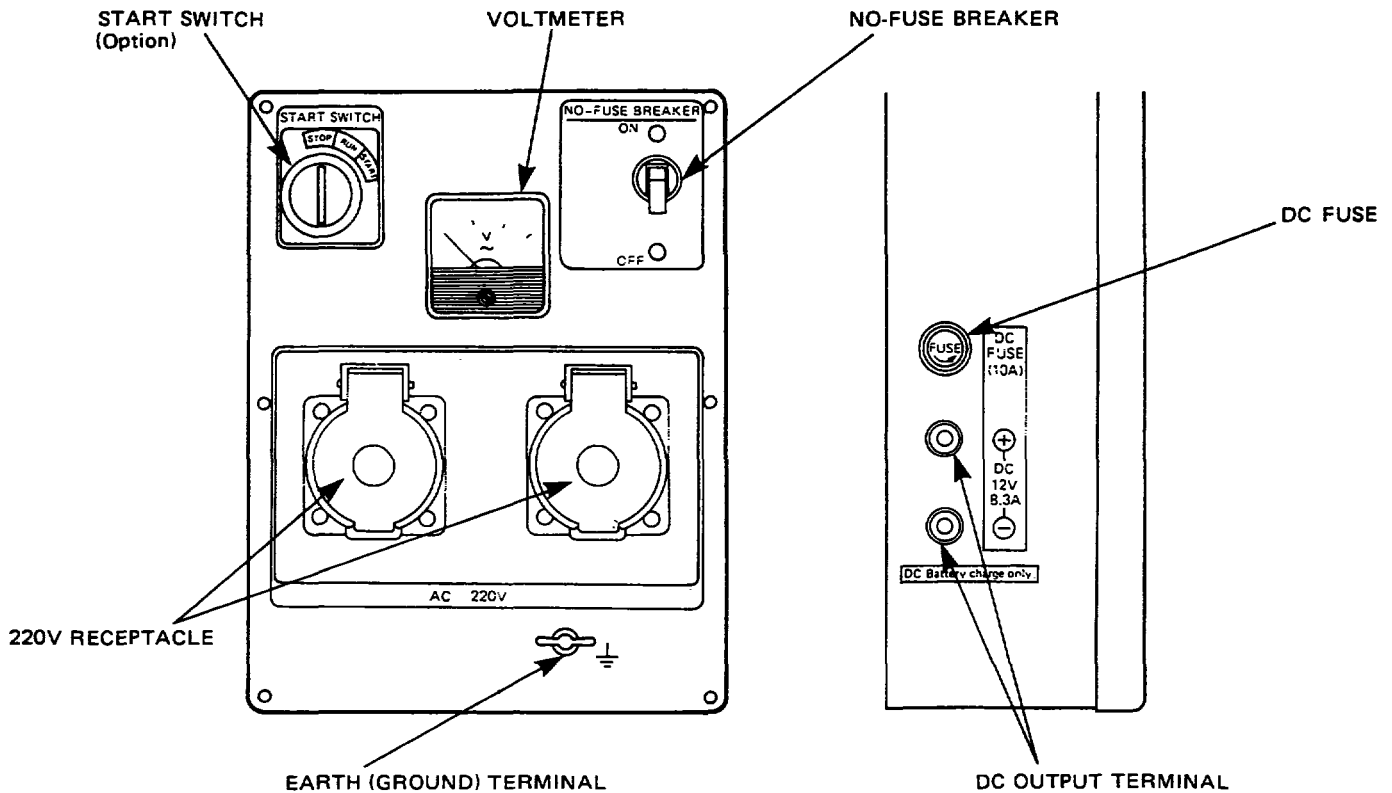

● **RGX3500 : 50Hz-220V [WITH SPECIAL RECEPTACLE]**

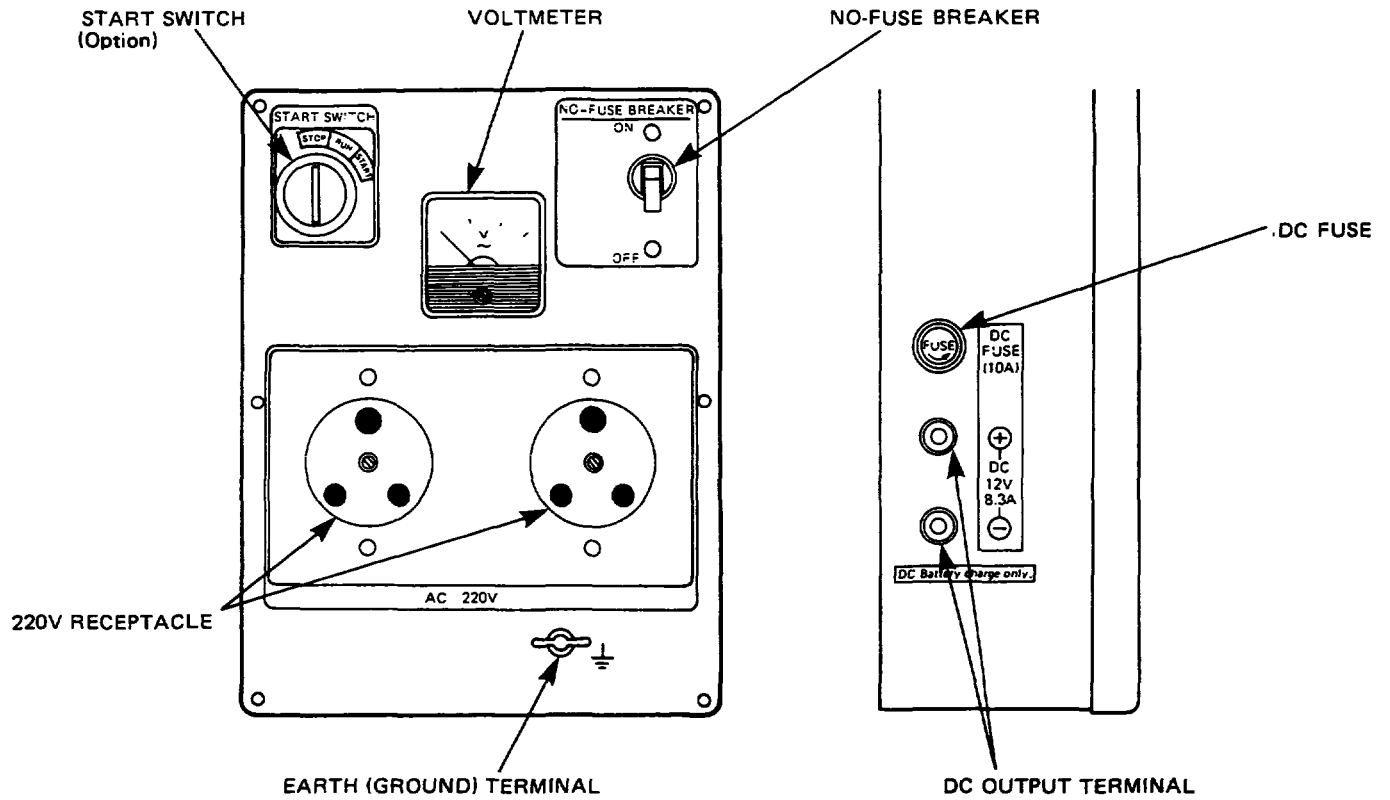

● **RGX3500 : SWITZERLAND, 50Hz-220V**

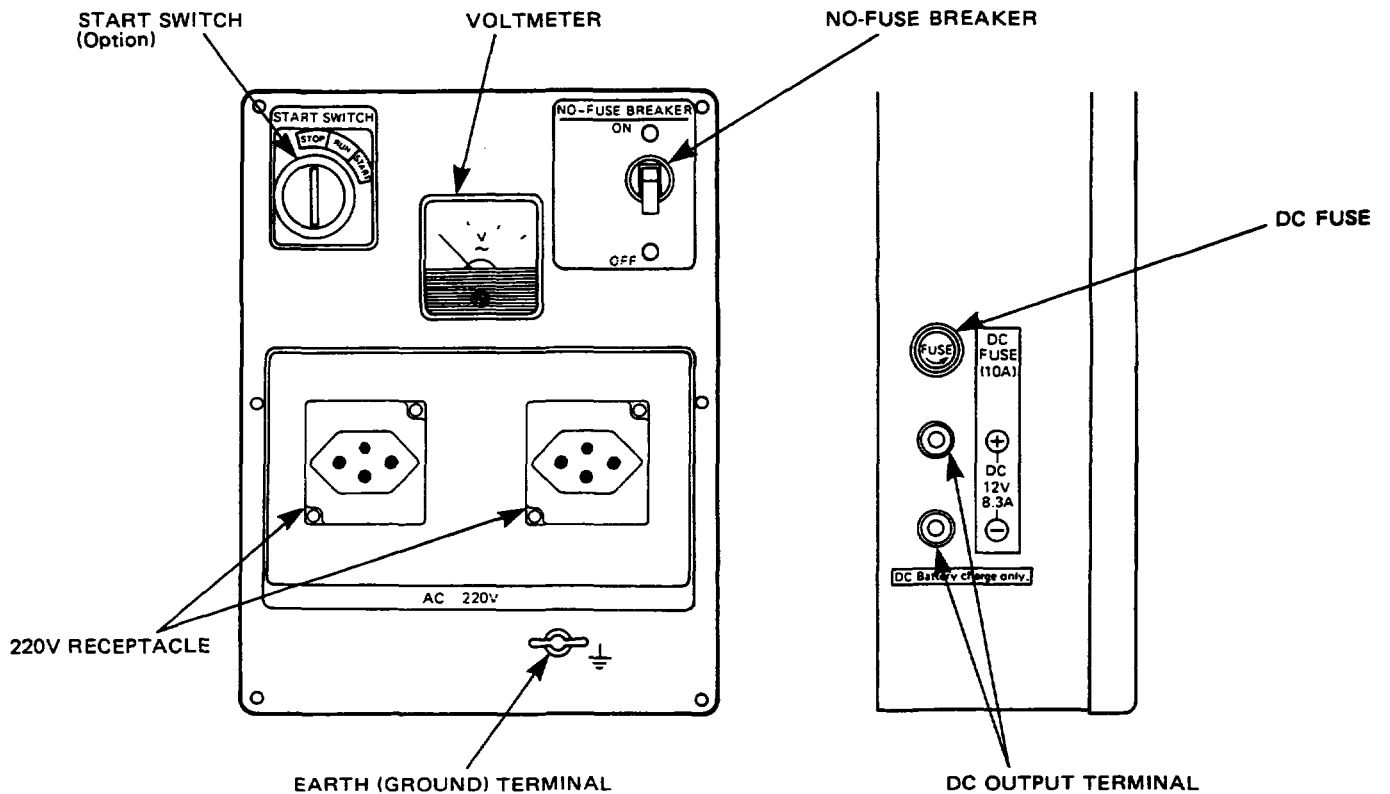

● **RGX3500 : AUSTRALIA, 50Hz-240V**

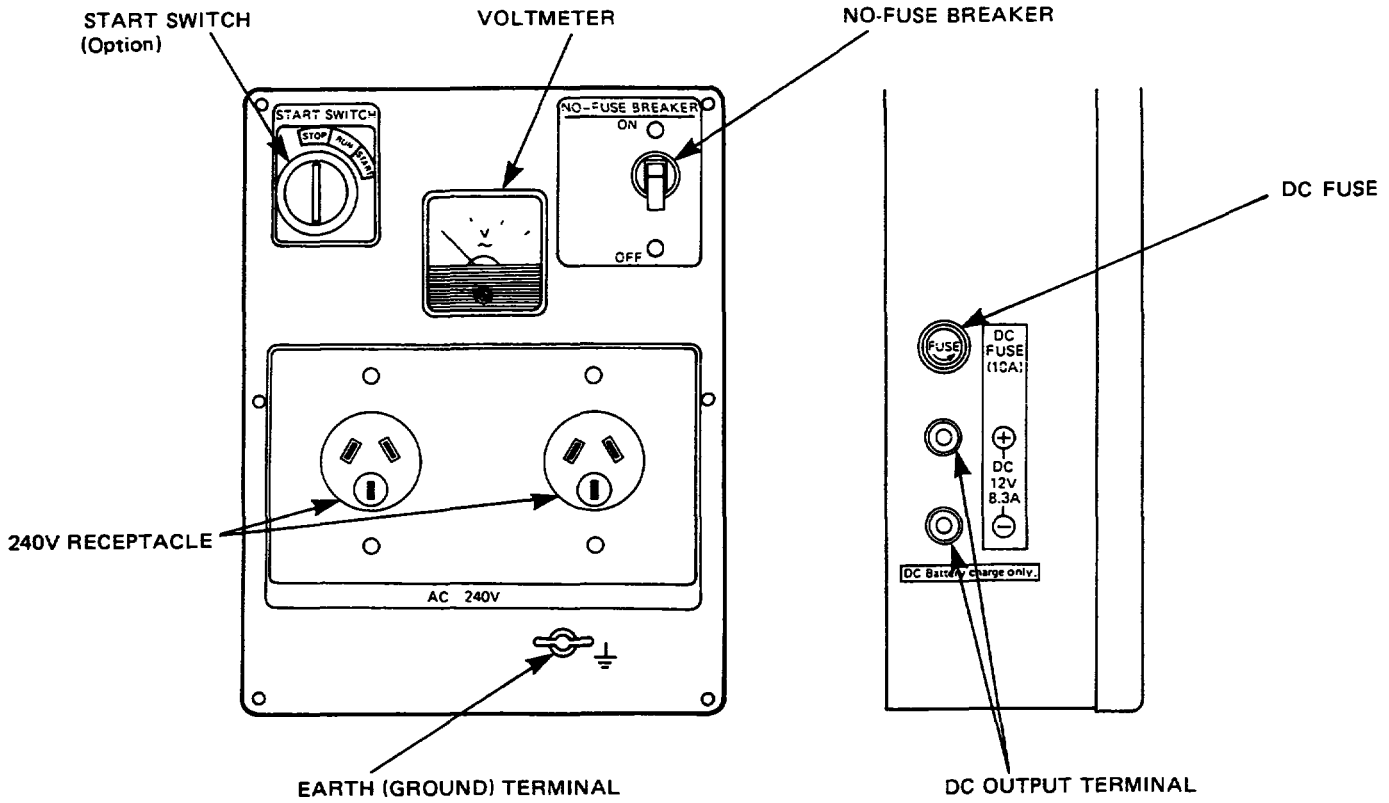

● **RGX5500 : 50Hz-110V, 60Hz-120V TYPE**

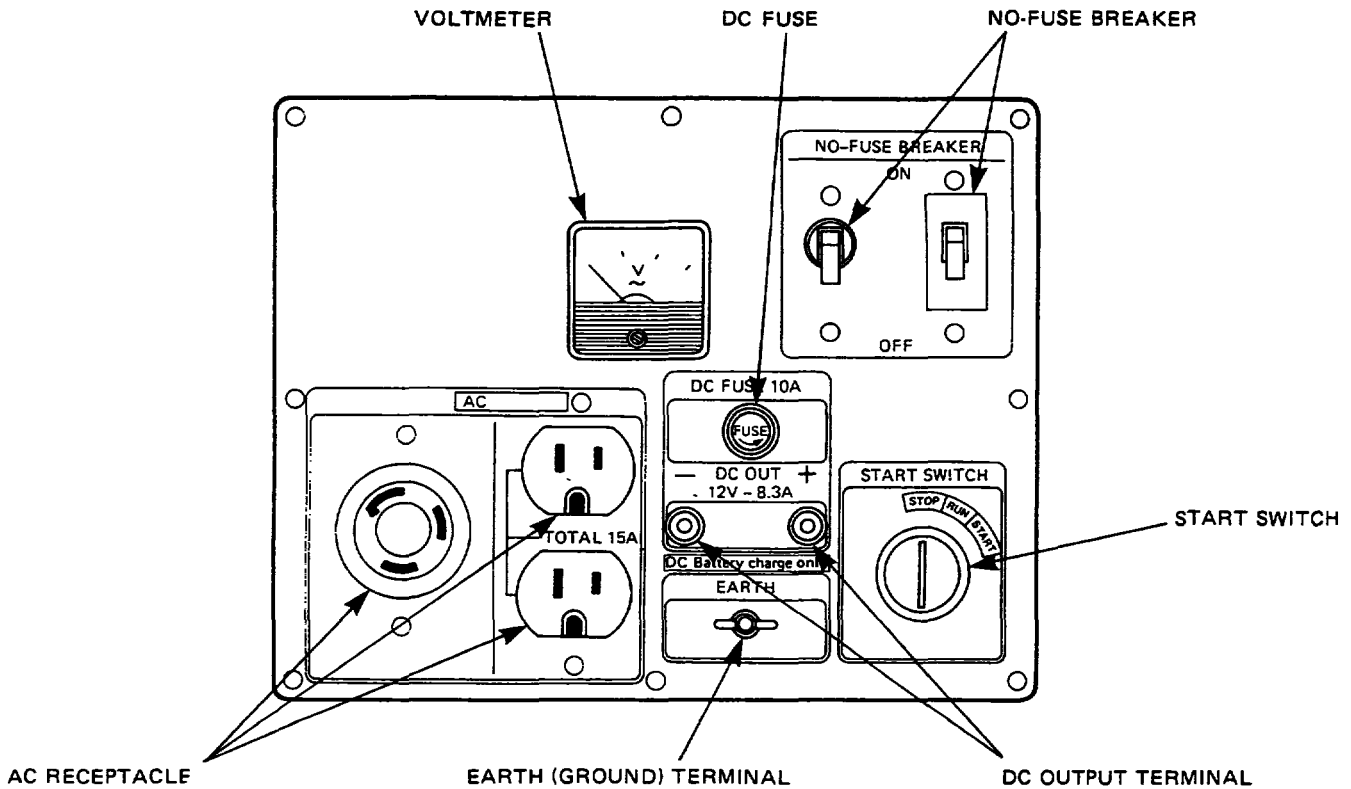

● **RGX5500 : 50Hz-220V, 240V, 60Hz-220V TYPE**

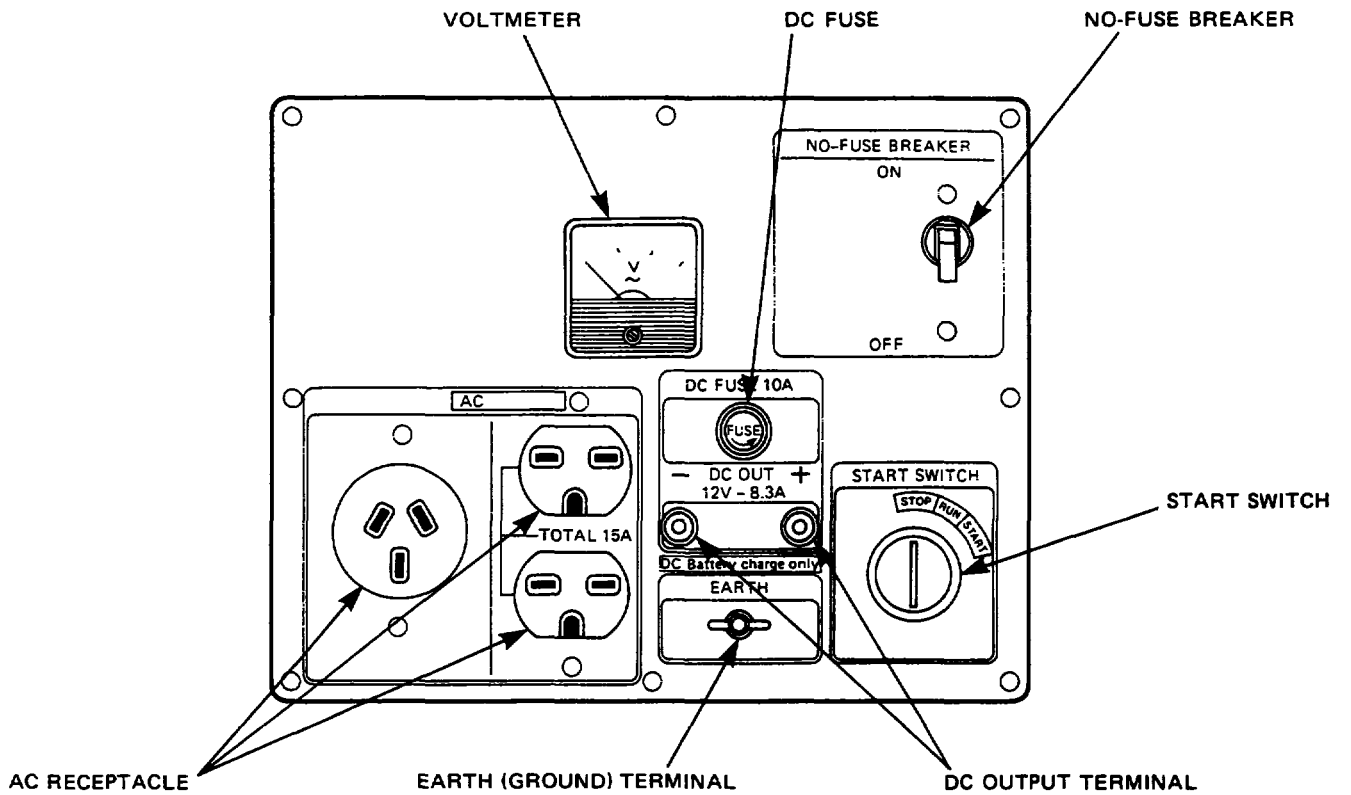

● **RGX5500 : 50Hz, 60Hz-110V/220V TYPE**

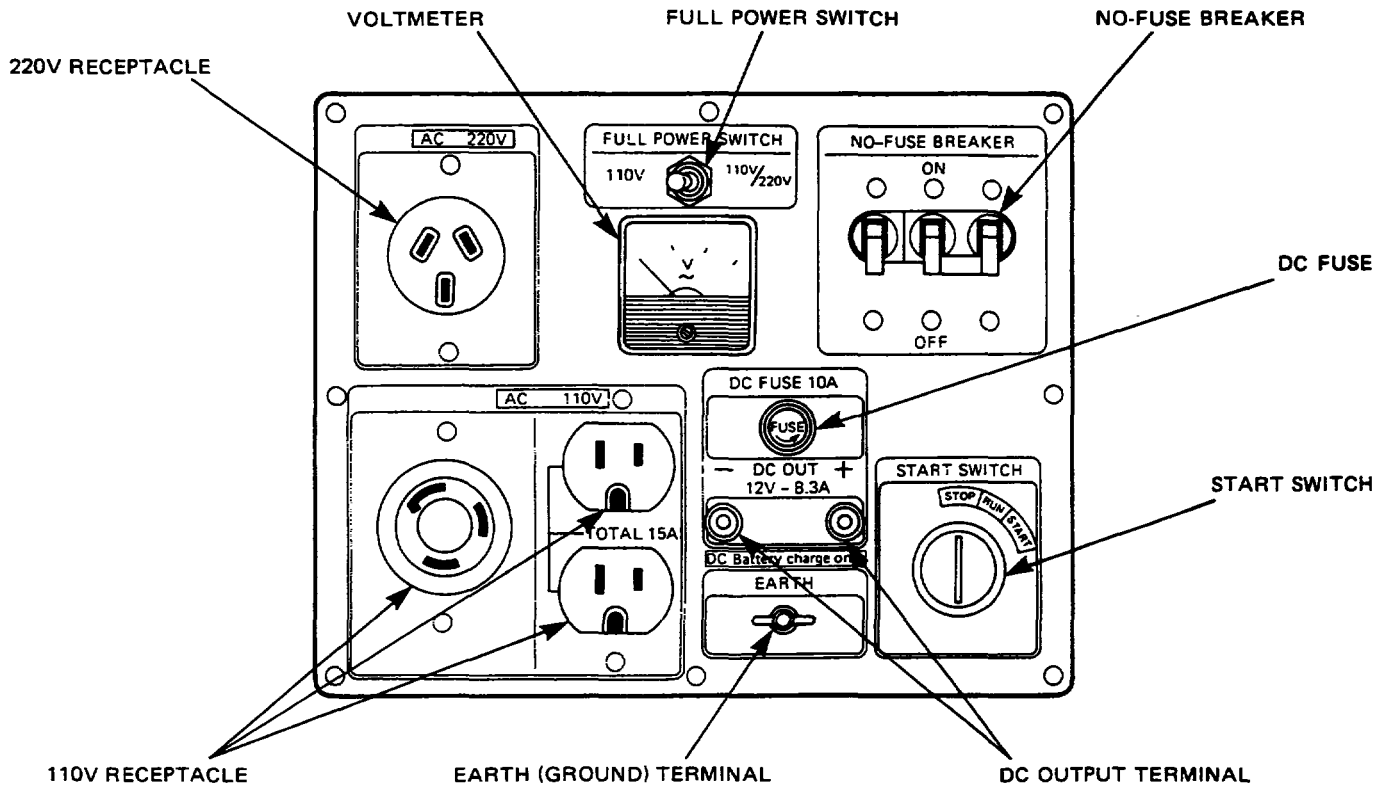

● **RGX5500 : U.K., 50Hz-110V/220V [BS RECEPTACLE]**

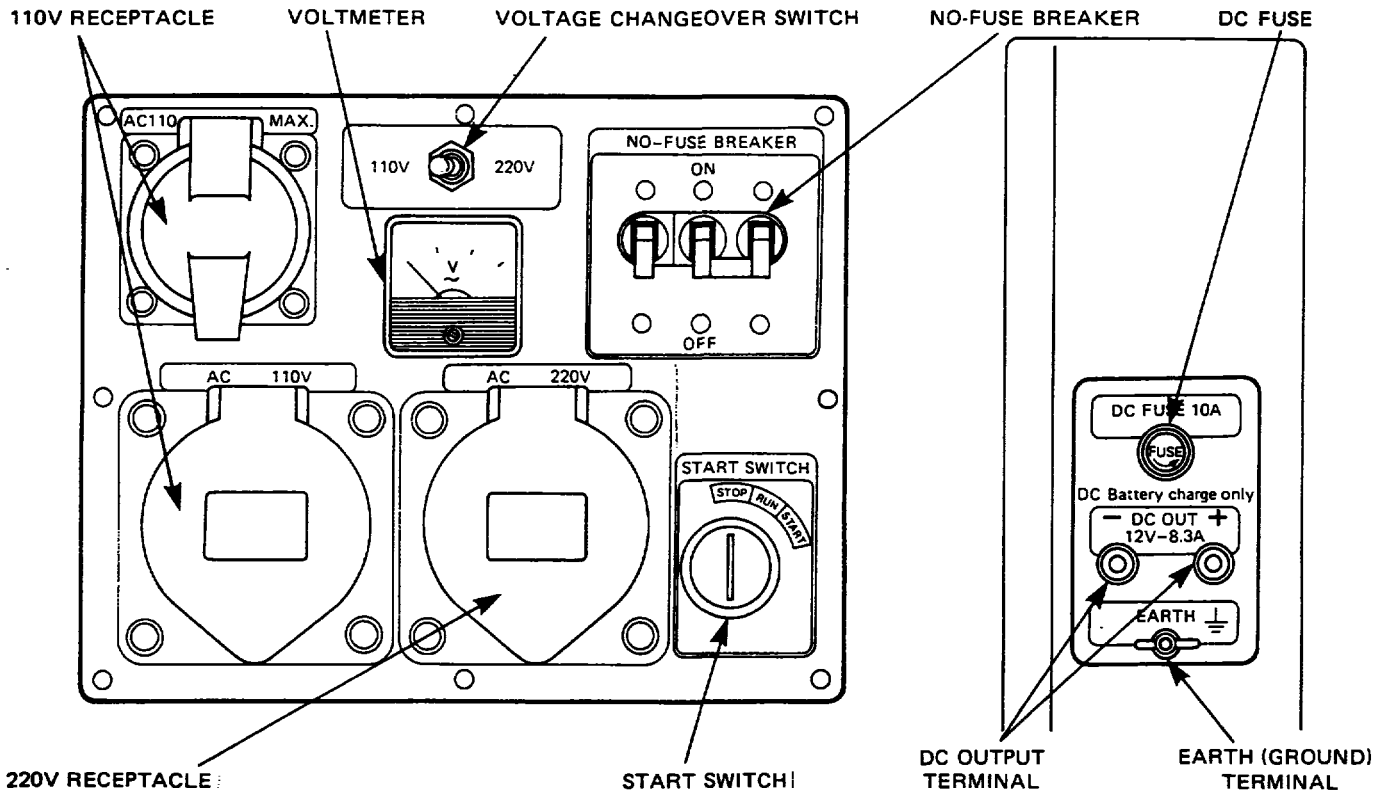

● **RGX5500 : U.S.A., 60Hz-120V/240V [NEMA RECEPTACLE]**

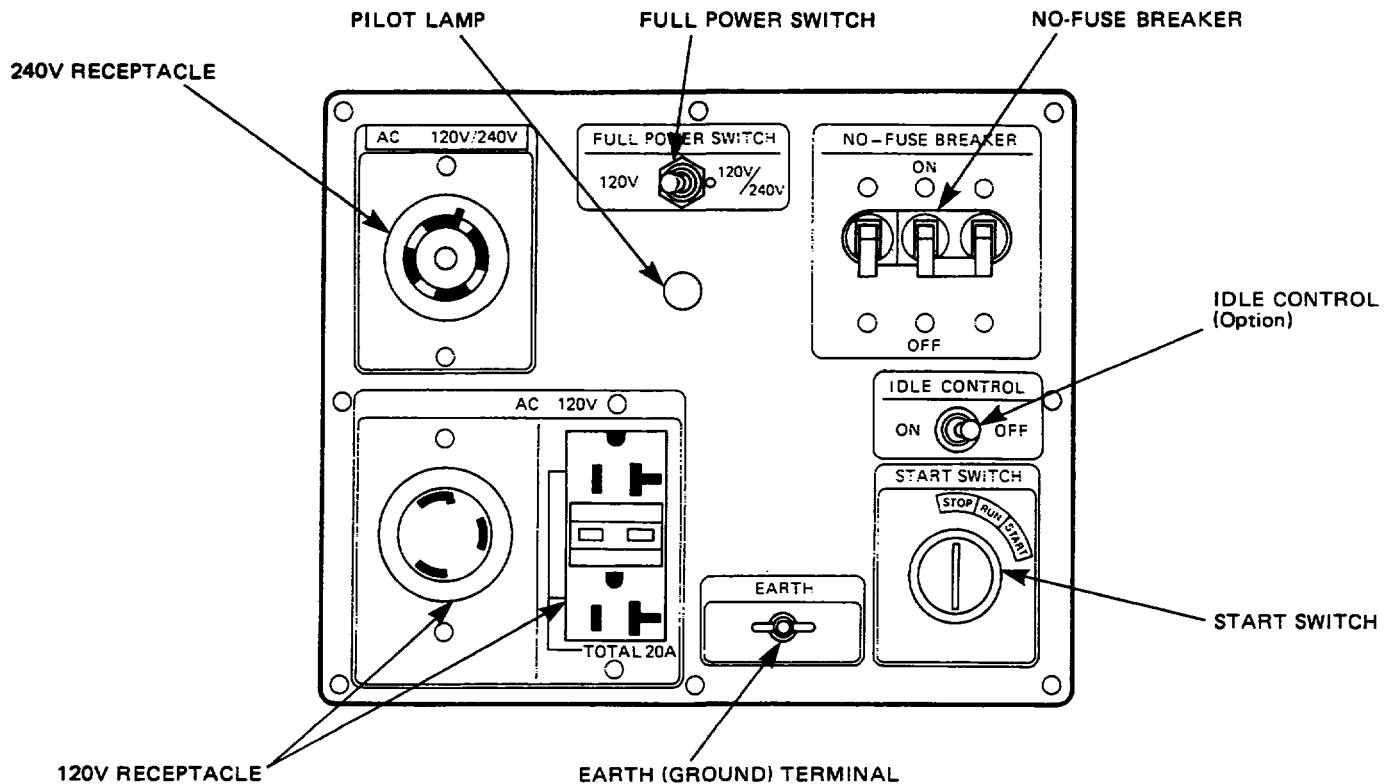

● **RGX5500 : GERMANY, 50Hz-220V**

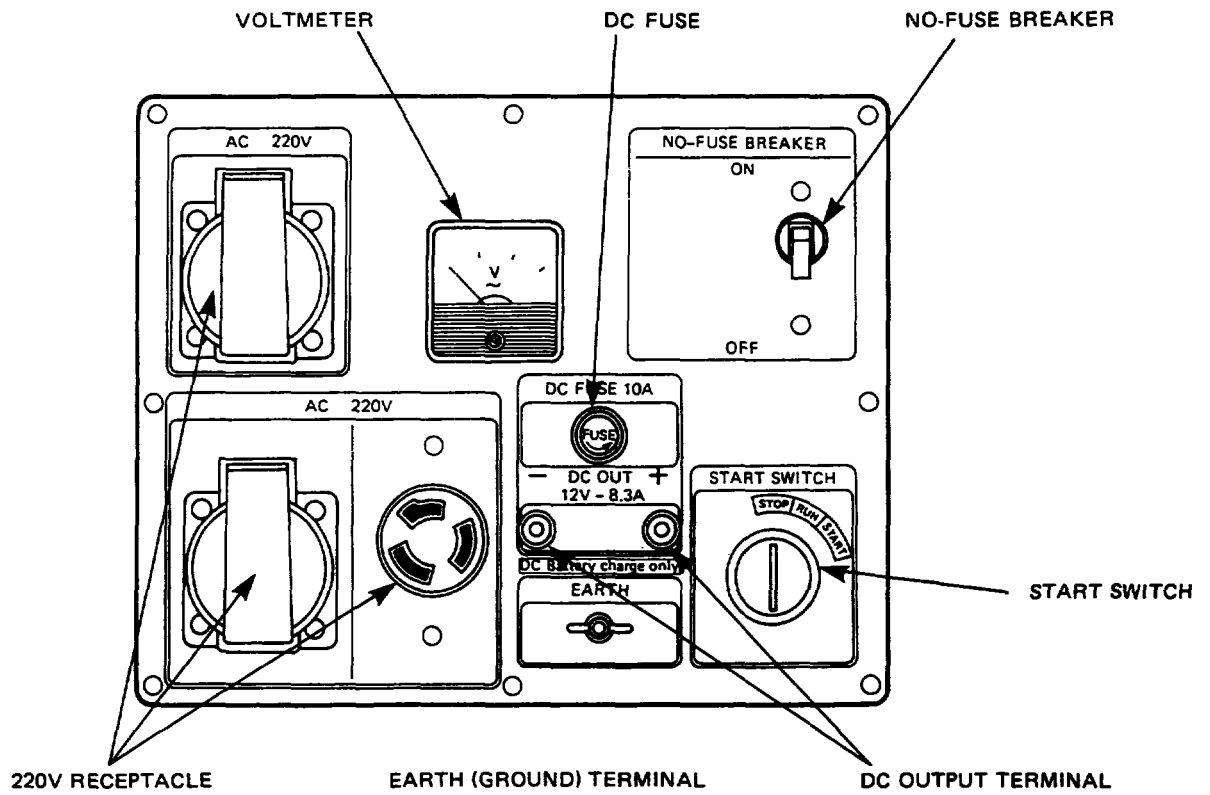

● **RGX5500 : 50Hz-220V [WITH SPECIAL RECEPTACLE]**

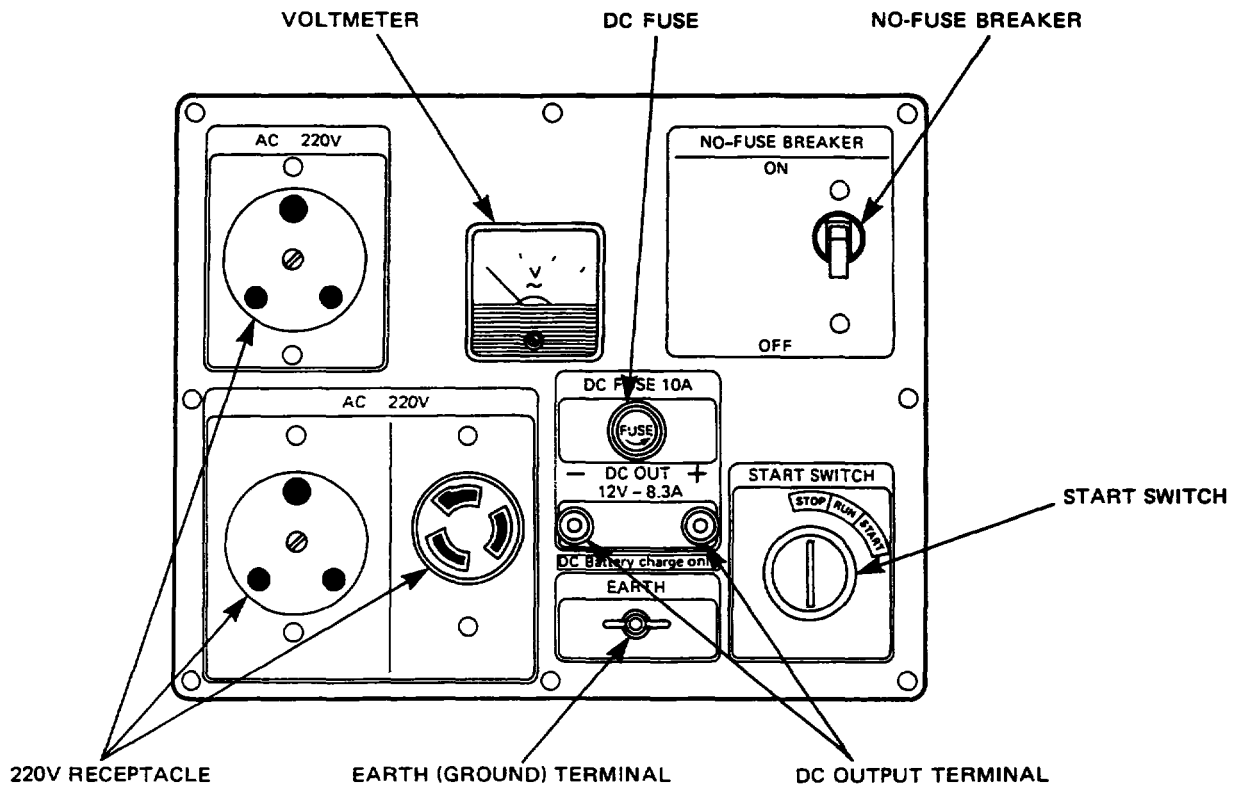

● **RGX5500 : SWITZERLAND, 50Hz-220V**

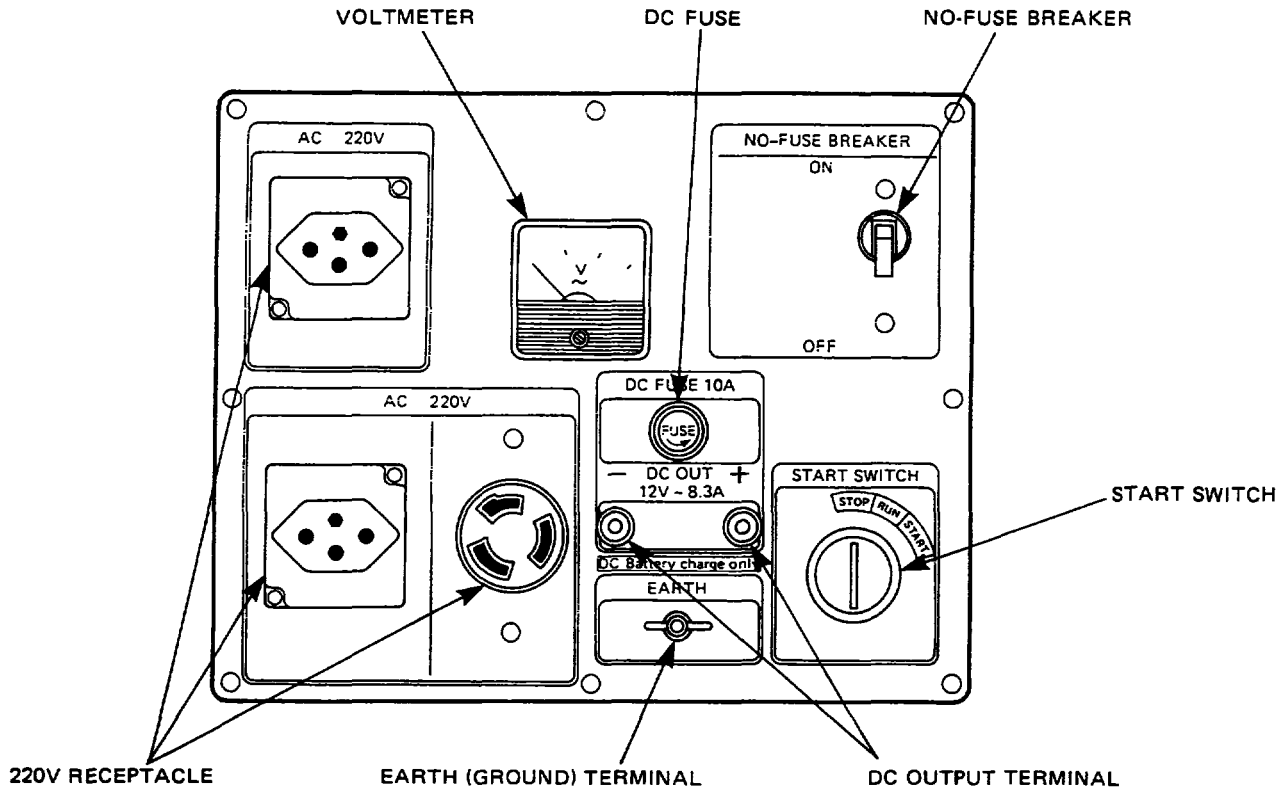

● **RGX5500 : AUSTRALIA, 50Hz-240V**

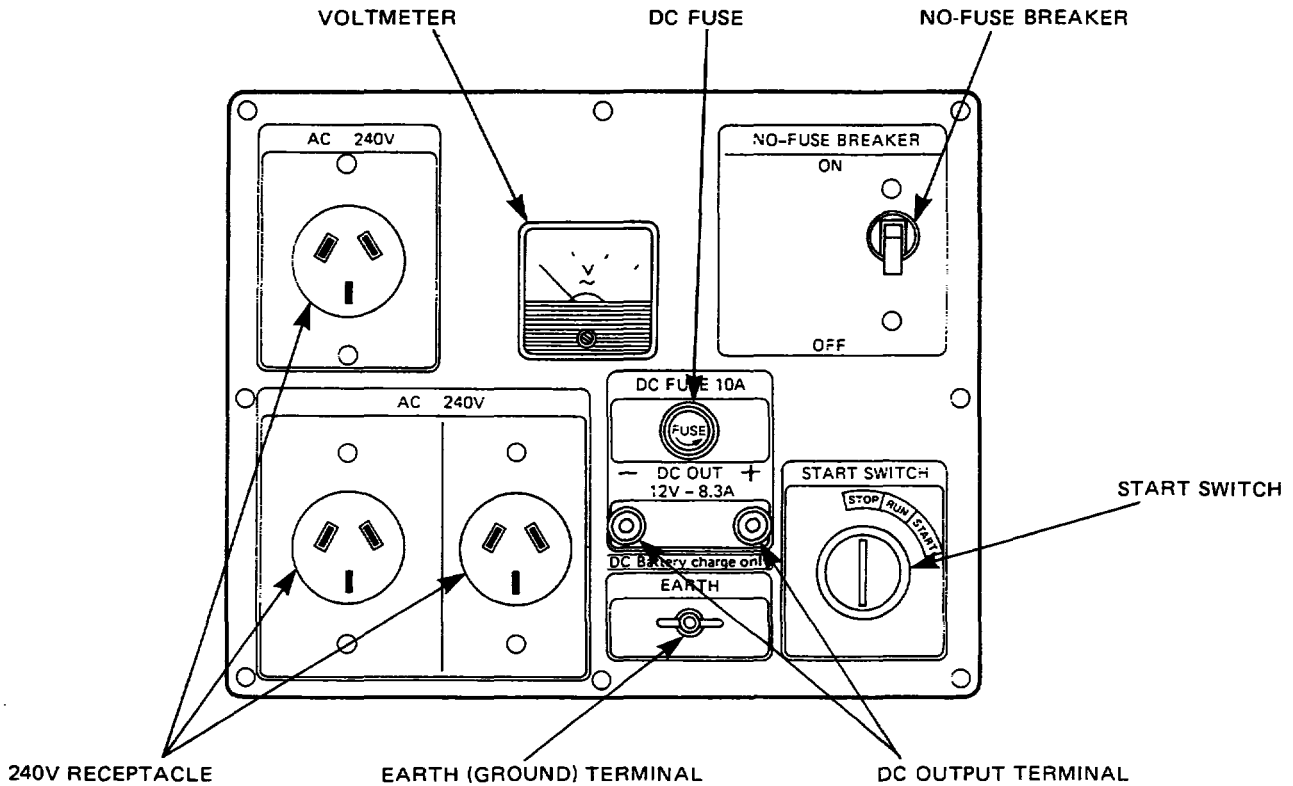

4-3 LOCATION of SERIAL NUMBER and SPECIFICATION NUMBER

Serial number and specification number are stamped on the LABEL (MODEL NAME) stuck on the end cover.

NOTE: Always specify these numbers when inquiring about the generator or ordering spare parts in order to get correct parts and accurate service.

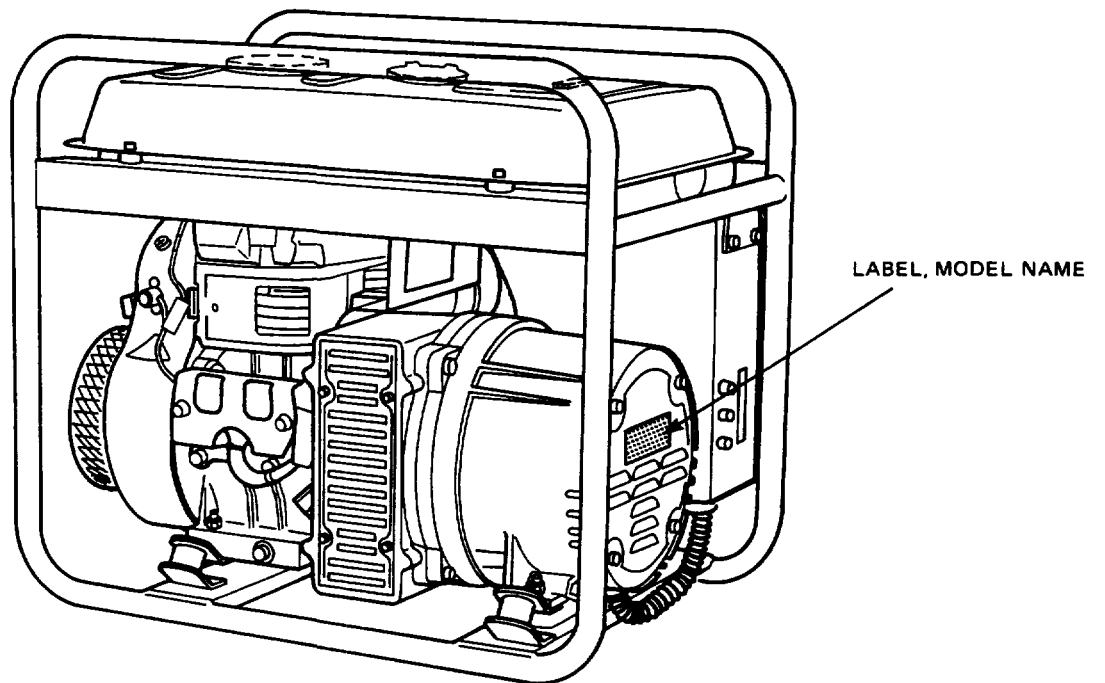

5. CONSTRUCTION AND FUNCTION

5-1 CONSTRUCTION

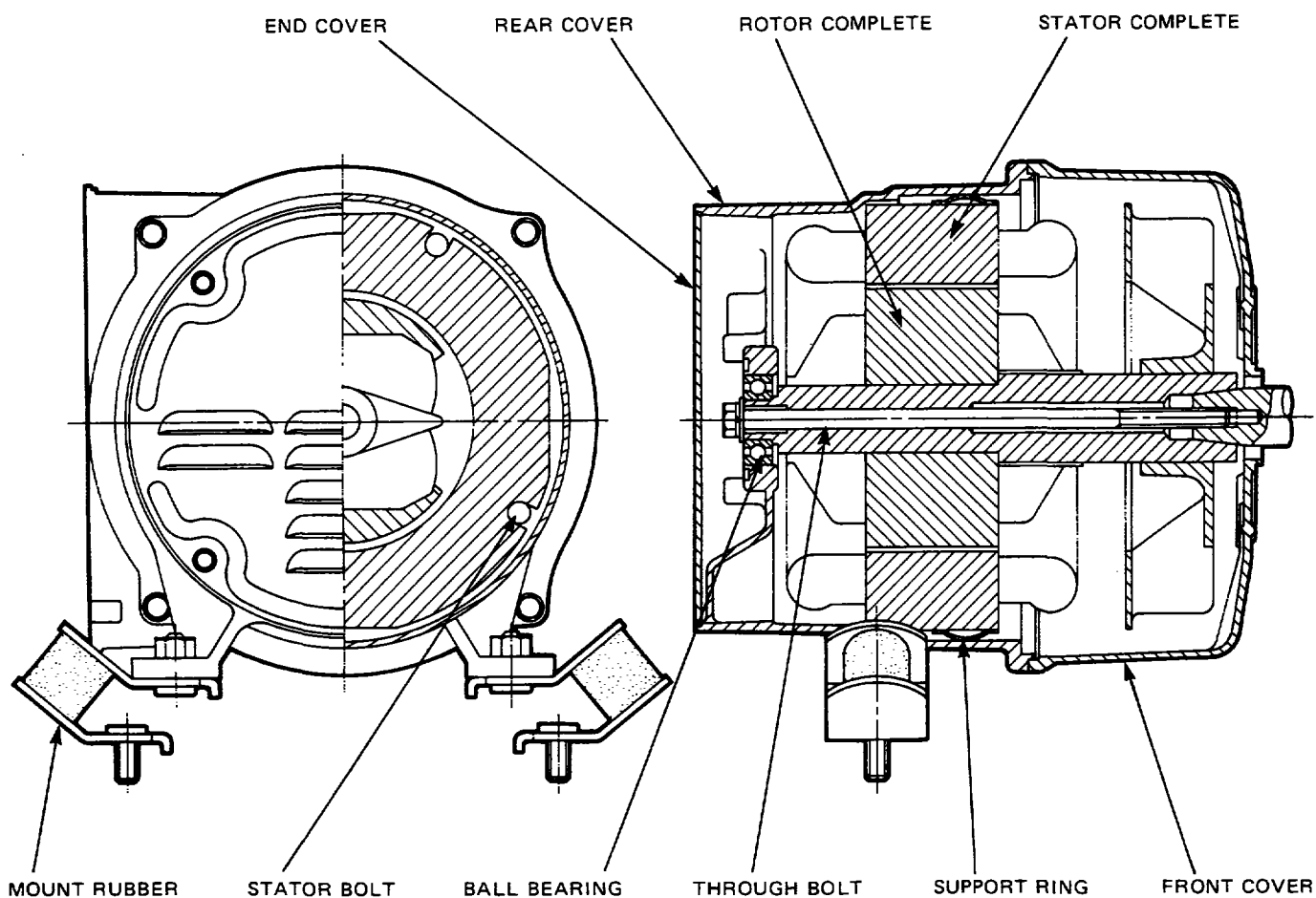

Fig. 5-1

5-2 FUNCTION

5-2-1 STATOR

The stator consists of a laminated silicon steel sheet core, a main coil and a condenser coil which are wound in the core slots.

The condenser coil excites the rotor field coil which generates AC voltage in the main coil.

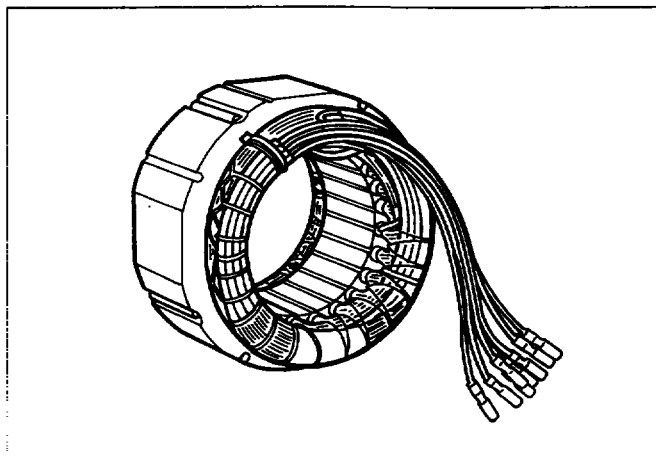

Fig. 5-2

5-2-2 CONDENSER

One or two condensers are installed in the control box and are connected to the condenser coil of the stator.

These condensers and condenser coil regulate the output voltage.

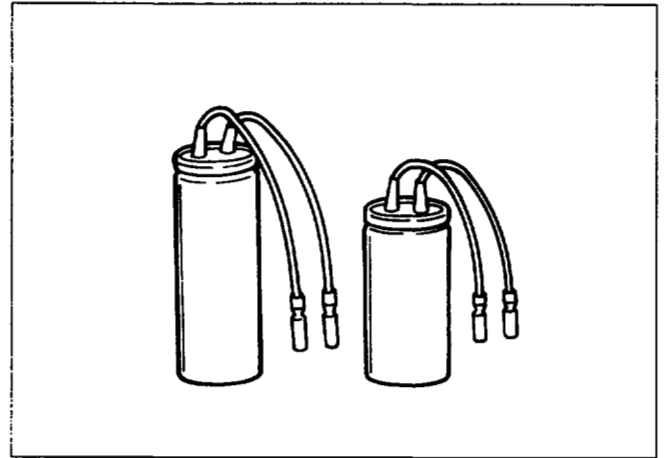

Fig. 5-3

5-2-3 ROTOR

The rotor consists of a laminated silicon steel sheet core and a field coil which is wound over the core.

DC current in the field coil magnetizes the steel sheet core. Two permanent magnets are provided for the primary exciting action.

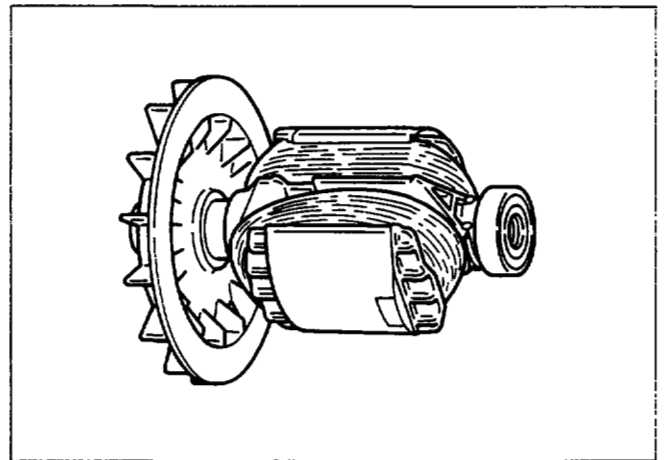

Fig. 5-4

A diode rectifier and surge absorber is mounted inside of the insulator.

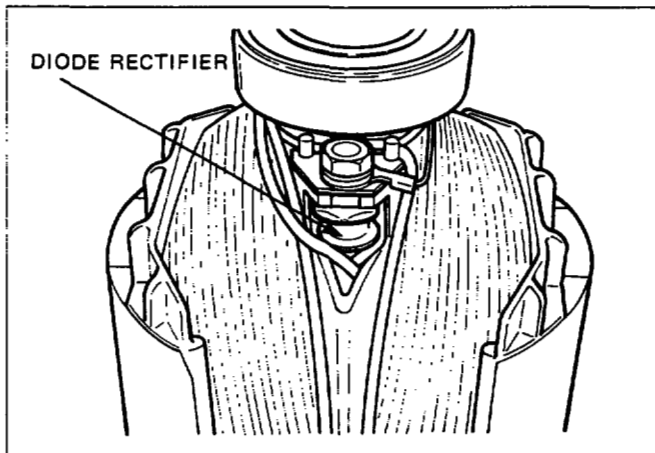

Fig. 5-5A

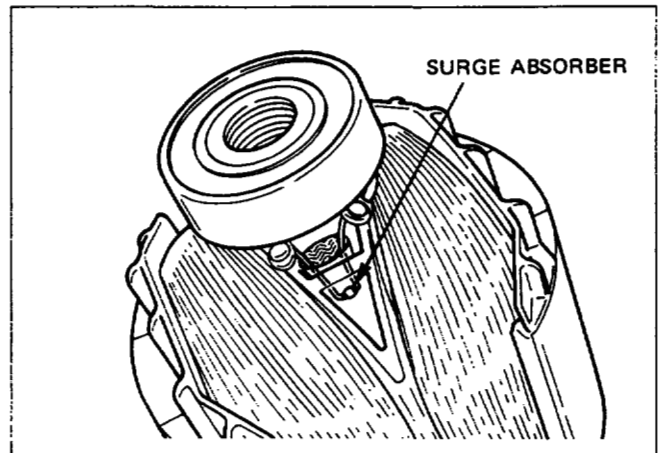

Fig. 5-5B

5-2-4 FUSE

(1) The 10 ampere DC fuse mounted on the control panel protects whole DC circuit from getting damage by overload or short circuit.

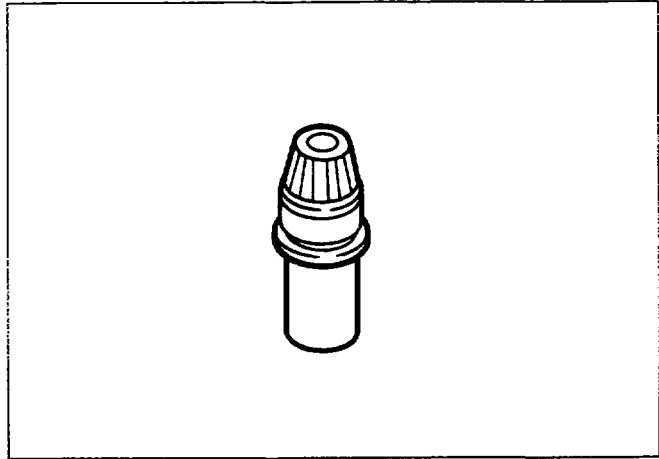

Fig. 5-6

5-2-5 NO-FUSE BREAKER

The no-fuse breaker protects the generator from getting damage by overloading or short circuit in the appliance. Table 5-1 shows the capacity of no-fuse breaker by each spec. and their object of protection.

MODEL	SPECIFICATION	NO-FUSE BREAKER	OBJECT of PROTECTION
RGX1800	110V, 120V	12A	Total output amperage
	220V	6.3A	Total output amperage
	240V	5A	Total output amperage
	110V/220V, 120V/240V	6.3A (2 pcs.)	Total output amperage
RGX2400	110V, 120V	15A	Total output amperage
	50Hz-220V, 240V	8A	Total output amperage
	60Hz-220V	10A	Total output amperage
	50Hz-110V/220V	8A (2 pcs.)	Total output amperage
	60Hz-110V/220V, 120V/240V	10A (2 pcs.)	Total output amperage
RGX3500	50Hz-110V	22A	Total output amperage
	60Hz-110V, 120V	25A	Total output amperage
	50Hz-220V	12A	Total output amperage
	60Hz-220V	14A	Total output amperage
	50Hz-240V	10A	Total output amperage
	50Hz-110V/220V	12A (2-Pole, 2-Element)	Total output amperage
	60Hz-110V/220V, 120V/240V	14A (2-Pole, 2-Element)	Total output amperage
RGX5500	110V, 120V	40A	Total output amperage
		30A	Output from 30A receptacle
	50Hz-220V	20A	Total output amperage
	60Hz-220V	22A	Total output amperage
	50Hz-240V	18A	Total output amperage
	50Hz-110V/220V	20A (2-Pole, 2-Element)	Total output amperage
		30A	Output from 30A receptacle
	60Hz-110V/220V, 120V/240V	22A (2-Pole, 2-Element)	Total output amperage
		30A	Output from 30A receptacle

Table 5-1

5-2-6 RECEPTACLE and AC PLUG (STD.SPEC.)

These are used for taking AC output power from the generator. A total of five kinds of receptacles, each varying in rated voltage and current from another, are used. Each model has at least one receptacle to deliver the rated generator output. As many AC plugs as the receptacles, each matching the corresponding receptacle, are provided. Table 5-2 shows the rated current for each receptacle. Be careful not to use the receptacles and AC plugs beyond the specified amperage limits to prevent burning.





	up to total 15 amperes from two receptacles
	up to 15 amperes
	up to 20 amperes
	up to 30 amperes (See Caution.)

Table 5-2



Caution: To connect the appliance to locking receptacle, insert the plug into the receptacle and turn it clockwise to lock.

Fig. 5-7

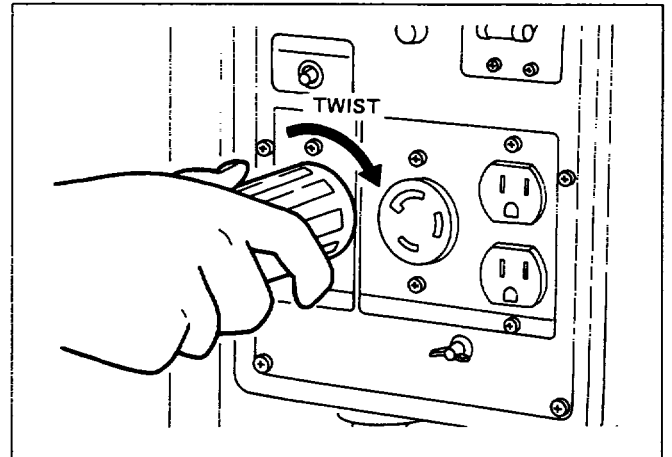
NOTE: If your generator has receptacles peculiar to your country, Table 5-2 does not apply.

NOTE: The generator for U.S.A. market is equipped with NEMA standard receptacles shown in table 5-3. Use the proper plug for connecting appliance to the generator.



Style	Ampere	Receptacle	AC plug	Description
	125V 20A	NEMA 5-20R	NEMA 5-20P	GFCI (Ground Fault Circuit Interrupter) Receptacle, duplex
	125V/250V 20A	NEMA L14-20R	NEMA L14-20P	Locking Receptacle
	125V 30A	NEMA L5-30	NEMA L5-30P	Locking Receptacle

Table 5-3

5-3 DESCRIPTION of GENERATOR OPERATION

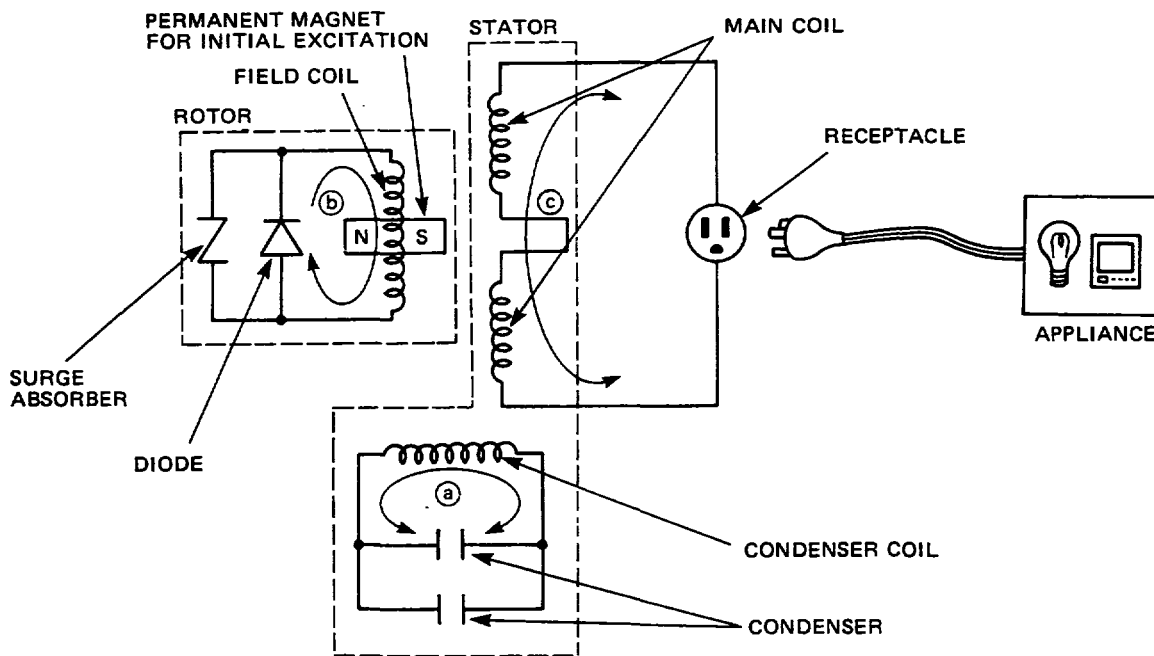

Fig. 5-8

5-3-1 GENERATION of NO-LOAD VOLTAGE

- (1) When the generator starts running, the permanent magnet built-in to the rotor generates 3 to 6V of AC voltage in the main coil and condenser coil wound on the stator.
- (2) As one or two condensers are connected to the condenser coil, the small voltage at the condenser coil generates a minute current **(a)** which flows through the condenser coil. At this time, a small flux is produced with which the magnetic force at the rotor's magnetic pole is intensified. When this magnetic force is intensified, the respective voltages in the main coil and condenser coil rise up. As the current **(a)** increases, the magnetic flux at the rotor's magnetic pole increases further. Thus the voltages at the main coil and condenser coil keep rising by repeating this process.
- (3) As AC current flows through the condenser coil, the density of magnetic flux in the rotor changes. This change of magnetic flux induces AC voltage in the field coil, and the diode rectifier in the field coil circuit rectifies this AC voltage into DC. Thus a DC current **(b)** flows through the field coil and magnetizes the rotor core to generate an output voltage in the main coil.
- (4) When generator speed reaches 2700 to 2800 rpm (50Hz type) or 3000 to 3300 rpm (60Hz type), the current in the condenser coil and field coil increases rapidly. This acts to stabilize the output voltage of each coils. If generator speed further increases to the rated value, the generator output voltage will reach to the rated value.

5-3-2 VOLTAGE FLUCTUATIONS UNDER LOAD

When the output current **(c)** flows through the main coil to the appliance, a magnetic flux is produced and serves to increase current **(a)** in the condenser coil. When current **(a)** increases, the density of magnetic flux across the rotor core rises. As a result, the current flowing in the field coil increases and the generator output voltage is prevented from decreasing.

5-3-3 FULL POWER SWITCH (Dual Voltage Type)

The full power switch is provided for the dual voltage type to take out the full rated power from one receptacle in each voltage.

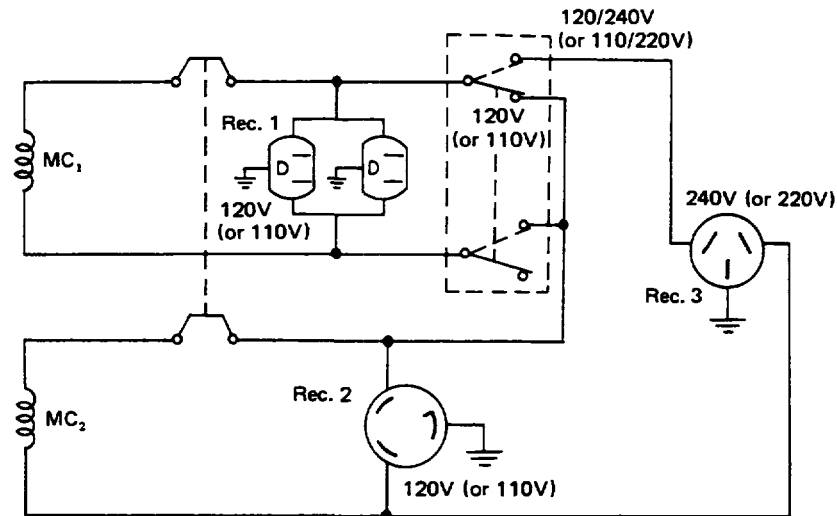

Fig. 5-9

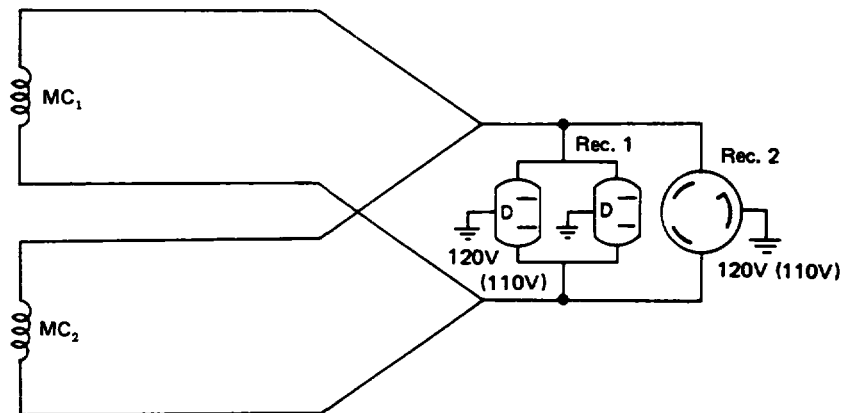

Fig. 5-10

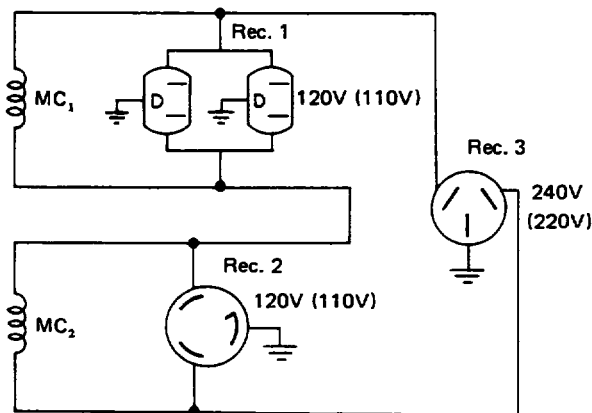

Fig. 5-11

Switch Position	LOWER VOLTAGE RECEPTACLE	HIGHER VOLTAGE RECEPTACLE
110V or 120V	Rated output	No output can be taken.
110/220V or 120/240V	Half of rated output	Rated output

Table 5-4

Two main coils are wound over stator core. Each main coil outputs half the rated power at the lower voltage (110V or 120V). These main coils are wound to be in the same phase. The full power switch reconnects these main coils in parallel or in series.

Fig. 5-9 shows a circuit diagram. When the full power switch is set for single lower voltage indication (110V or 120V), the switch position is as indicated by the lower solid line in the diagram. Fig. 5-10 is a simplified representation of this circuit, showing the two main coils connected in parallel. In this case, the higher voltage (220V or 240V) at Rec. 3 cannot be taken out. Rec. 2 for the lower voltage can output up to the rated power (up to 30A if the rated current is over 30A), and Rec. 1 can output up to a total of 15A. When the full power switch is set for double voltage indication (110V/220V or 120V/240V), the switch position is as indicated by the upper dotted line in Fig. 5-9. Fig. 5-11 is a simplified representation of this circuit, showing the two main coils connected in series. In this case, power can be taken simultaneously from the receptacles for the both voltages. Rec. 3 for the higher voltage can output up to the rated power, but Rec. 1 and Rec. 2 for the lower voltage can output only up to half the rated power each.

Table 5-4 is a summary of the above explanation. Select the proper output voltage by full power switch in accordance with the appliance to be used.

5-3-4 VOLTAGE CHANGEOVER SWITCH

The generator of 50Hz 110V/220V dual voltage type for U.K. is provided with voltage changeover switch instead of full power switch.

The output voltage is selected from 110V and 220V by turning this switch and both voltages cannot be taken out simultaneously.

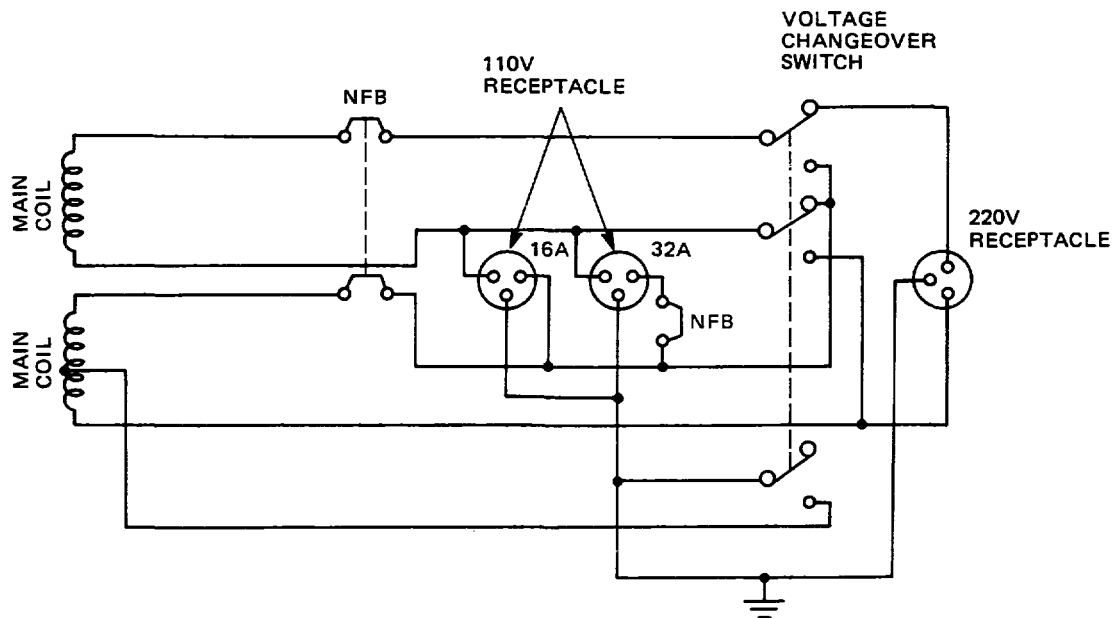

Fig. 5-12

6. SAFETY PRECAUTIONS

1. Use extreme caution near fuel. A constant danger of explosion or fire exists.

Do not fill the fuel tank while the engine is running. Do not smoke or use open flame near the fuel tank. Be careful not to spill fuel when refueling. If spilt, wipe it and let dry before starting the engine.

2. Do not place inflammable materials near the generator.

Be careful not to put fuel, matches, gunpowder, oily cloth, straw, and any other inflammables near the generator.

3. Do not operate the generator in a room, cave or tunnel. Always operate in a well-ventilated area.

Otherwise the engine may overheat and also, the poisonous carbon monoxide contained in the exhaust gases will endanger human lives. Keep the generator at least 1 m (4 feet) away from structures or facilities during use.

4. Operate the generator on a level surface.

If the generator is tilted or moved during use, there is a danger of fuel spillage and a chance that the generator may tip over.

5. Do not operate with wet hands or in the rain.

Severe electric shock may occur. If the generator is wet by rain or snow, wipe it and thoroughly dry it before starting.

Don't pour water over the generator directly nor wash it with water.

If the generator is wet with water, the insulations will be adversely affected and may cause current leakage and electric shock.

6. Do not connect the generator to the commercial power lines.

This may cause a short-circuit or damage to the generator. Use a transfer switch for connecting with indoor wiring.

NOTE: The parts numbers of the transfer switches and of the plastic box to store them are as shown in Table 6-1.

Part No.	Part Name	Q'ty	Phase	Allowable Current
365-45604-08	Transfer Switch	1	1	15A
367-45605-08	Transfer Switch	1	1	30A
340-45606-08	Transfer Switch	1	1	60A
367-43008-08	Plastic Box	1	1	30A
348-43009-08	Plastic Box	1	1	60A

Table 6-1

7. Use a fuse of the correct capacity. (DC output)

If the generator rpm is increased excessively in the overload condition by using an over rated fuse, the generator may be burnt.

CAUTION: If the fuse is burnt or the circuit breaker tripped off as a result of using an electrical appliance, the cause can be an overload or a short-circuit. In such a case, stop operation immediately and carefully check the electrical appliance and AC plugs for faulty wiring.

7. RANGE OF APPLICATIONS

Generally, the power rating of an electrical appliance indicates the amount of work that can be done by it. The electric power required for operating an electrical appliance is not always equal to the output wattage of the appliance. The electrical appliances generally have a label showing their rated voltage, frequency, and power consumption (input wattage). The power consumption of an electrical appliance is the power necessary for using it. When using a generator for operating an electrical appliance, the power factor and starting wattage must be taken into consideration.

In order to determine the right size generator, it is necessary to add the total wattage of all appliances to be connected to the unit.

Refer to the followings to calculate the power consumption of each appliance or equipment by its type.

(1) Incandescent lamp, heater, etc. with a power factor of 1.0

Total power consumption must be equal to or less than the rated output of the generator.

Example: A rated 3000W generator can turn thirty 100W incandescent lamps on.

(2) Fluorescent lamps, mercury lamps, etc. with a smaller power factor

Select a generator with a rated output equivalent to 1.2 to 2 times of the power consumption of the load.

Example: A 400W mercury lamp requires 600W to 700W power source to be turned on.

A rated 3000W generator can power four or five 400W mercury lamps.

NOTE1: *If a power factor correction capacitor is not applied to the mercury lamp or fluorescent lamp, the more power shall be required to drive those lamps.*

A rated 3000W generator can drive one or two 400W mercury lamps without power factor correction capacitors.

NOTE2: *Nominal wattage of the fluorescent lamp generally indicates the output wattage of the lamp.*

Therefore, if the fluorescent lamp has no special indication as to the power consumption, efficiency should be taken into account as explained in Item (5) on the following page.

(3) Motor driven tools and light electrical appliances

Generally the starting wattage of motor driven tools and light electrical appliances are 1.2 to 3 times larger than their running wattage.

Example: A rated 250W electric drill requires a 400W generator to start it.

(4) Initially loaded motor driven appliances such as water pumps, compressors, etc.

These appliances require large starting wattage which is 3 to 5 times of running wattage.

Example: A rated 900W compressor requires a 4500W generator to drive it.

NOTE1: *Motor-driven appliances require the aforementioned generator output only at the starting. Once their motors are started, the appliances consume about 1.2 to 2 times their rated power consumption so that the excess power generated by the generator can be used for other electrical appliances.*

NOTE2: *Motor-driven appliances mentioned in Items (3) and (4) vary in their required motor starting power depending on the kind of motor and start-up load. If it is difficult to determine the optimum generator capacity, select a generator with a larger capacity.*

(5) Appliances without any indication as to power consumption

Some appliances have no indication as to power consumption; but instead the work load (output) is indicated. In such a case, power consumption is to be worked out according to the numerical formula mentioned below.

$$\frac{\text{(Output of electrical appliance)}}{\text{(Efficiency)}} = \text{(Power consumption)}$$

Efficiencies of some electrical appliances are as follows:

- Single-phase motor 0.6 ~ 0.75
 - Three-phase motor 0.65 ~ 0.9
 - Fluorescent lamp 0.7 ~ 0.8
- } The smaller the motor, the lower the efficiency.

Example 1: A 40W fluorescent lamp means that its luminous output is 40W. Its efficiency is 0.7 and accordingly, power consumption will be $40 \div 0.7 = 57W$. As explained in **Item(2)**, multiply this power consumption value of 57W by 1.2 ~ 2 and you will get the figure of the necessary capacity of a generator. In other words, a generator with a rated output of 1000W capacity can light nine to fourteen 40W fluorescent lamps.

Example 2: Generally speaking, a 400W motor means that its work load is 400W. Efficiency of this motor is 0.7 and power consumption will be $400 \div 0.7 = 570W$. When this motor is used for a motor-driven tool, the capacity of the generator should be multiplied by 1.2 to 3 and 570W as explained in the **Item(3)**.

MODEL	RGX1800		RGX2400		RGX3500		RGX5500	
	50Hz	60Hz	50Hz	60Hz	50Hz	60Hz	50Hz	60Hz
Incandescent lamp, heater, etc.	1300W	1500W	1700W	2000W	2500W	3000W	4400W	4800W
Fluorescent lamp, mercury lamp, etc.	approx. 900W	approx. 1000W	approx. 1100W	approx. 1300W	approx. 1700W	approx. 2000W	approx. 2800W	approx. 3200W
Motor-driven tool, general-purpose motor, etc.	approx. 800W	approx. 900W	approx. 1000W	approx. 1200W	approx. 1500W	approx. 1800W	approx. 2600W	approx. 2900W
Water pump, compressor, etc.	approx. 400W	approx. 450W	approx. 500W	approx. 600W	approx. 750W	approx. 900W	approx. 1300W	approx. 1400W

Table 7-1

NOTES: Wiring between generator and electrical appliances

1. Allowable current of cable

Use a cable with an allowable current that is higher than the rated input current of the load (electrical appliance). If the input current is higher than the allowable current of the cable used, the cable will become excessively heated and deteriorate the insulation, possibly burning it out.

Table 7-2 shows cables and their allowable currents for your reference.

2. Cable length

If a long cable is used, a voltage drop occurs due to the increased resistance in the conductors decreasing the input voltage to the load (electrical product). As a result, the load can be damaged.

Table 7-2 shows voltage drops per 100 meters of cable.

Nominal cross section	A.W.G. Gauge No.	Allowable current	No. of strands/strands dia.	Resistance	Current Amp.							Voltage drop
					1A	3A	5A	8A	10A	12A	15A	
mm ²	No.	A	No. / mm	Ω /100 m	1A	3A	5A	8A	10A	12A	15A	
0.75	18	7	30 / 0.18	2.477	2.5V	8V	12.5V	—	—	—	—	
1.27	16	12	50 / 0.18	1.486	1.5V	5V	7.5V	12V	15V	18V	—	
2.0	14	17	37 / 0.26	0.952	1V	3V	5V	8V	10V	12V	15V	
3.5	12 - 10	23	45 / 0.32	0.517	—	1.5V	2.5V	4V	5V	6.5V	7.5V	
5.5	10 ~ 8	25	70 / 0.32	0.332	—	1V	2V	2.5V	3.5V	4V	5V	

Table 7-2

Voltage drop indicates as $V = \frac{1}{100} \times R \times I \times \ell$

R means resistance (Ω /100 m) on the above table.

I means electric current through the wire (A).

ℓ means the length of the wire (m).

The length of wire indicates round length, it means twice the length from generator to electrical tools.

8. MEASURING PROCEDURES

8-1 MEASURING INSTRUMENTS

8-1-1 "Dr. ROBIN" GENERATOR TESTER

The "Dr. Robin" generator tester is exclusively designed for fast, easy diagnosis and repair of Robin generators.

The "Dr. Robin" has the following features:

- (1) Functions of voltmeter, frequency meter, megger tester, capacitance meter and circuit tester are combined in one unit.
- (2) Fast and easy readout by digital indicator.
- (3) Built-in automatic battery checker indicates the time to change batteries.
- (4) Tester and accessories are installed in a handy, sturdy case for easy carrying.

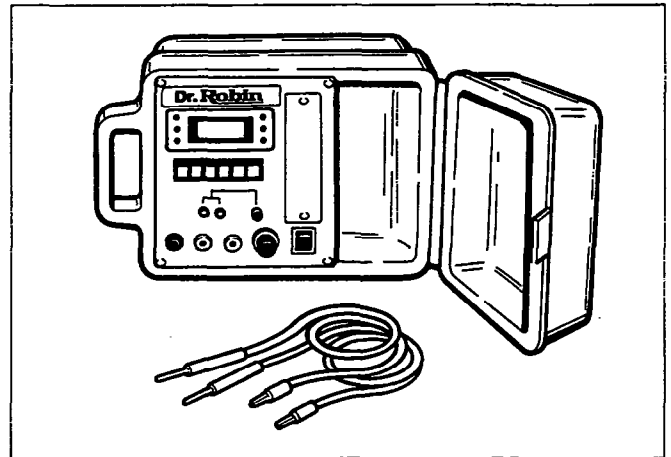

Fig. 8-1

● SPECIFICATIONS

Model		Dr. Robin
Part Number		388-47565-08
Measuring Range	Voltage	0-500V AC
	Frequency	25-70Hz
	Resistance	0.1-1,999 Ω
	Condenser Capacity	10-100 μ F
	Insulation Resistance	3M Ω
Circuit Protector		Fuse
Power Source		2 x 6F44P (006P) Dry Cell Battery
Accessories		Test leads with needle probes . . . 1 set Test leads with jack plugs 1 set
Dimensions (L x W x H)		285 mm x 200 mm x 110 mm
Weight		1.6kg

Table 8-1

The "Dr. Robin" generator tester can be ordered from Robin generator distributors by the following part number.

Dr. Robin Part Number : 388-47565-08

If you do not have a "Dr. Robin" generator tester, use the instruments described in the following section for checking generator parts.

8-1-2 INSTRUMENTS

(1) VOLTMETER

AC voltmeter is necessary. The approximate AC voltage ranges of the voltmeters to be used for various types of generators are as follows:

0 to 150V: Type with an output voltage of 110 or 120V

0 to 300V: Type with an output voltage of 220, 230 or 240V

0 to 150V, 0 to 330V: Dual voltage type

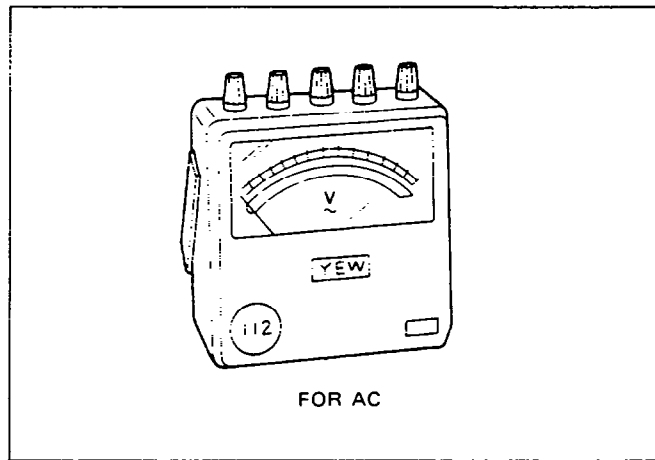

Fig. 8-2

(2) AMMETERS

AC ammeter is necessary. An AC ammeter with a range that can be changed according to the current rating of a given generator is most desirable. (About 10A, 20A, 100A)

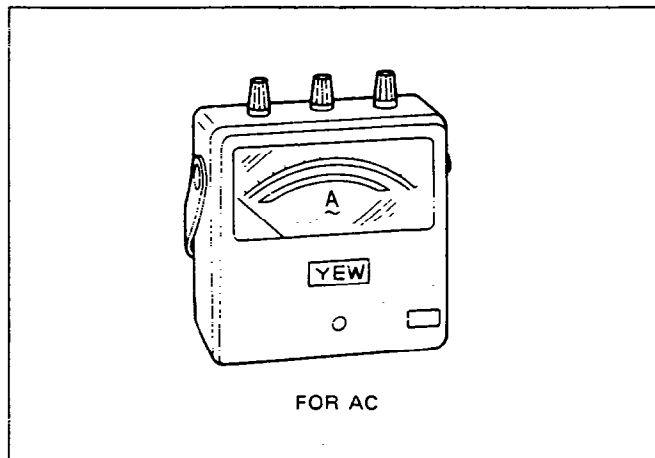

Fig. 8-3

(3) FREQUENCY METER

Frequency range : About 45 to 65Hz

NOTE: Be careful of the frequency meter's input voltage range.

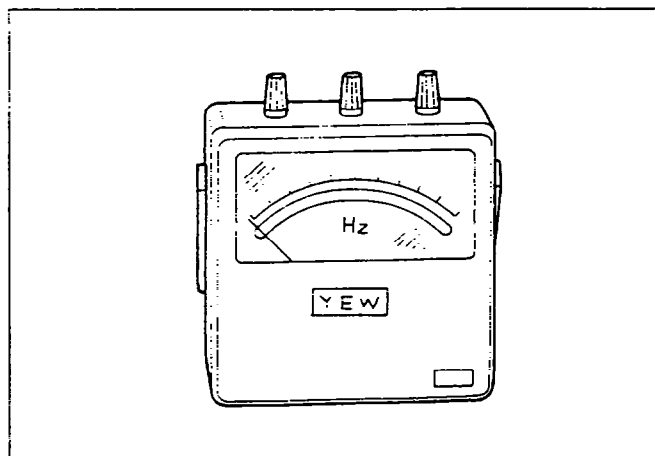

Fig. 8-4

(4) **CIRCUIT TESTER**

Used for measuring resistance, etc.

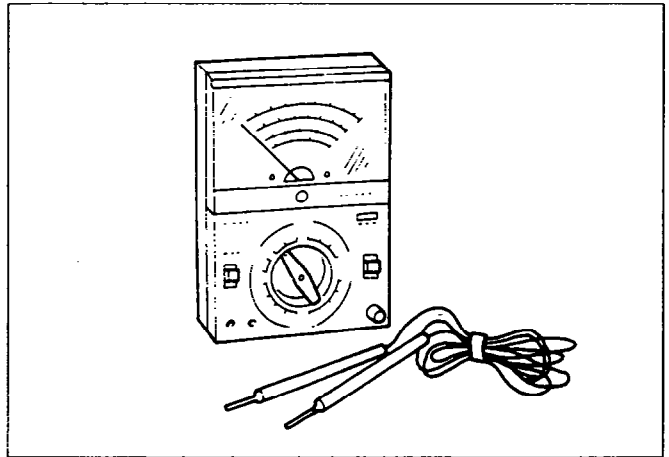

Fig. 8-5

(5) **MEGGER TESTER**

Used for measuring generator insulation resistance.

Select one with testing voltage range of 500V.

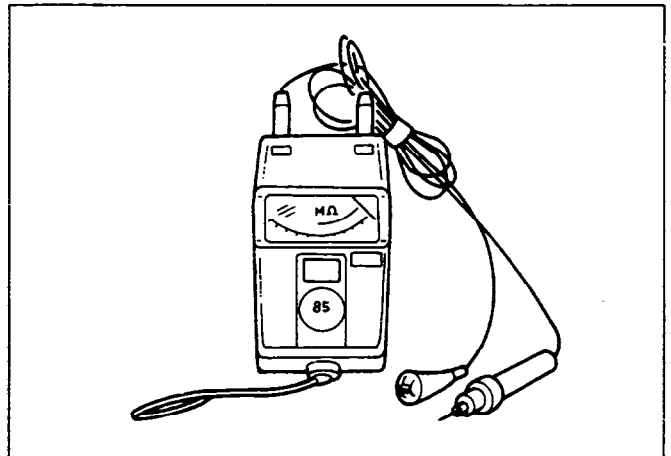

Fig. 8-6

(6) **TACHOMETER**

There are various types of tachometers, such as contactless type, contact type, and strobe type. The contact type can be used only when the generator and engine have been disassembled. The contactless type is recommended.

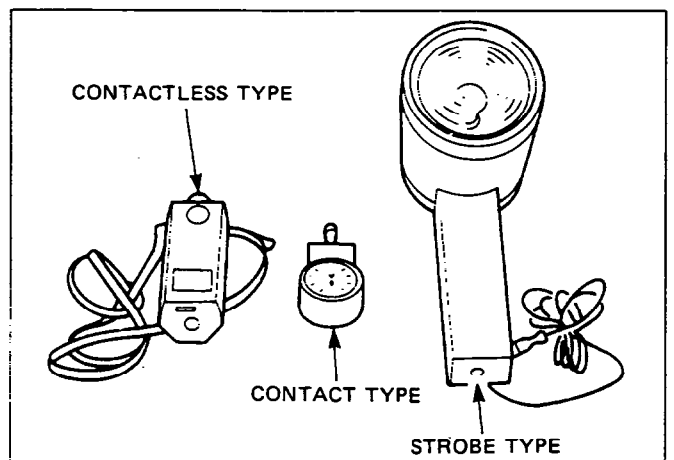

Fig. 8-7

8-2 AC OUTPUT MEASURING

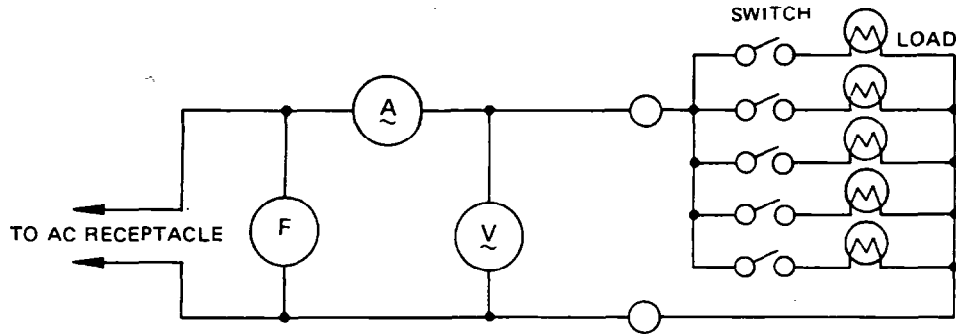

Fig. 8-8

Use a circuit like the shown in Fig.8-8 for measuring AC output. A hot plate or lamp with a power factor of 1.0 may be used as a load. Adjust the load and rpm. and check that the voltage range is as specified in Table 8-2 at the rated amperage and rated rpm.

Rated voltage	110V	120V	220V	240V
Voltage range	107~119V	117~130V	215~238V	235~280V

Table 8-2

8-3 MEASURING INSULATION RESISTANCE

Use a "Dr. Robin" generator tester in megger tester mode or use a megger tester to check the insulation resistance. Connect a megger tester to one of receptacle output terminals and the ground terminal, then measure the insulation resistance. An insulation resistance of 1 megohm or more is normal. (The original insulation resistance at the time of shipment from the factory is 10 megohm or more.)

If it is less than 1 megohm, disassemble the generator and measure the insulation resistance of the stator, rotor and control panel individually.

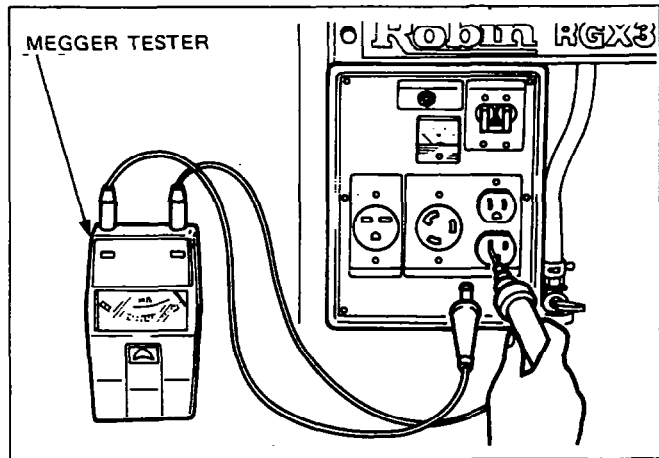

Fig. 8-9

● STATOR

- (1) Measure the insulation resistance between BLUE lead and the core.
- (2) Measure the insulation resistance between WHITE lead and the core.
- (3) Measure the insulation resistance between YELLOW lead and the core.
- (4) Measure the insulation resistance between BROWN lead and the core.

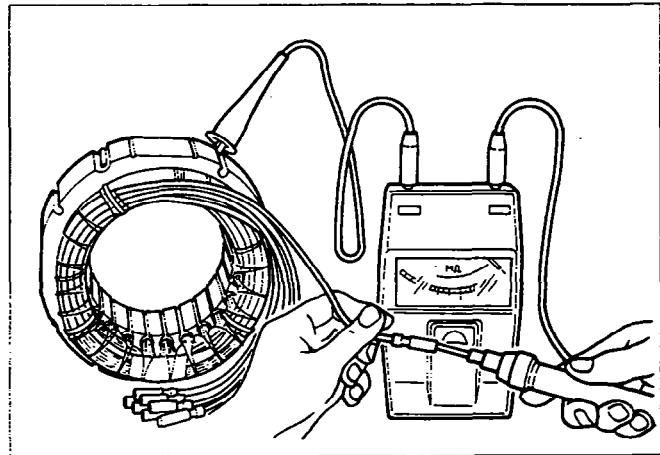

Fig. 8-10

● **ROTOR**

Measure the insulation across one of the soldered terminals of the rotor and the core.

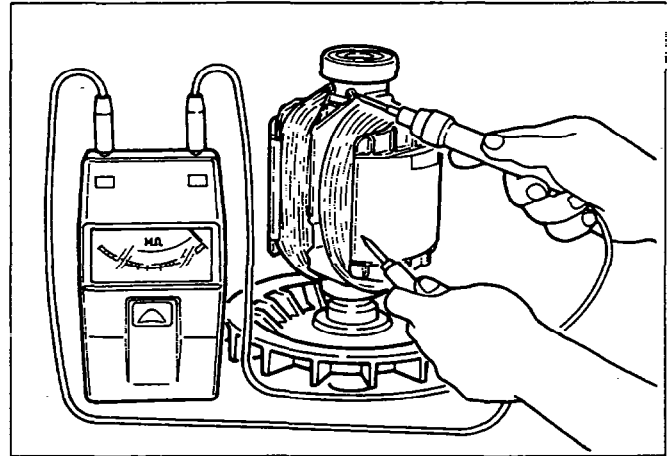

Fig. 8-11

● **CONTROL PANEL**

Measure the insulation resistances between the live parts and the grounded parts.

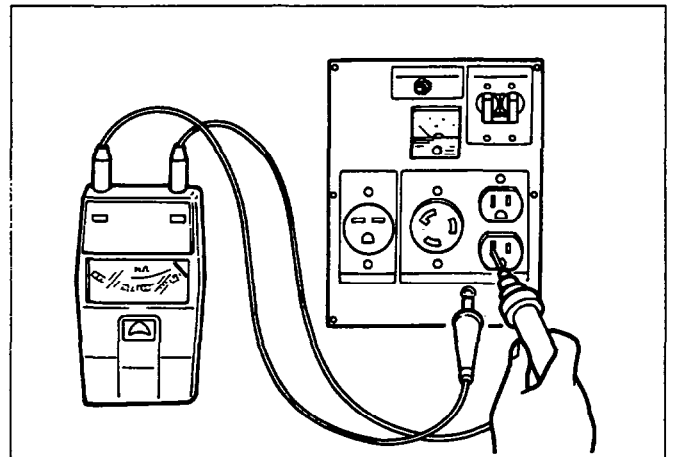

Fig. 8-12

Any part where the insulation resistance is less than $1M\Omega$ has faulty insulation, and may cause electric leakage and electric shock.

Replace the faulty part.

9. CHECKING FUNCTIONAL MEMBERS

9-1 PILOT LAMP and VOLTMETER

Check the pilot lamp and the voltmeter if it is turned on by applying specific voltage.

Pilot lamp and voltmeter cannot be checked with circuit tester because its resistance is too large. (See Fig.9-1.)

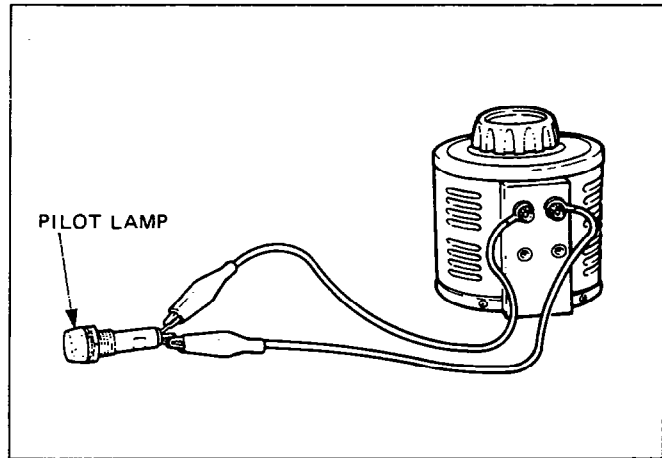

Fig. 9-1

Pilot lamp should be turned on at 70 to 120V.

9-2 AC RECEPTACLES

Using a "Dr. Robin" or a circuit tester, check continuity between the two terminals at the rear of the AC receptacles while the receptacle is mounted on the control panel. When continuity is found between the output terminals of the receptacle with a wire connected across these terminals, the AC receptacle is normal. When the wire is removed and no continuity is found between these terminals, the receptacles are also normal.

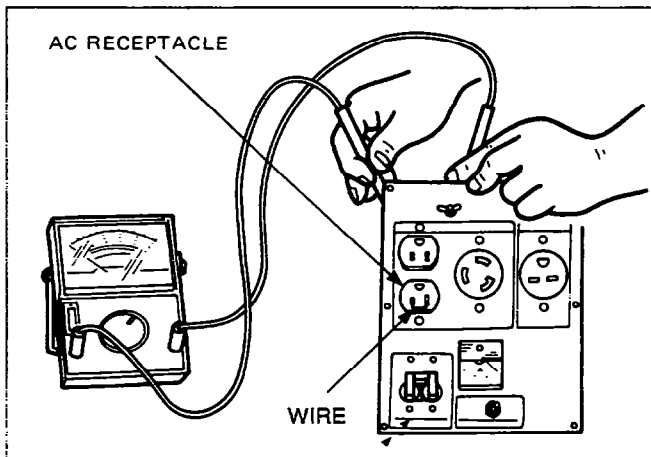

Fig. 9-2A

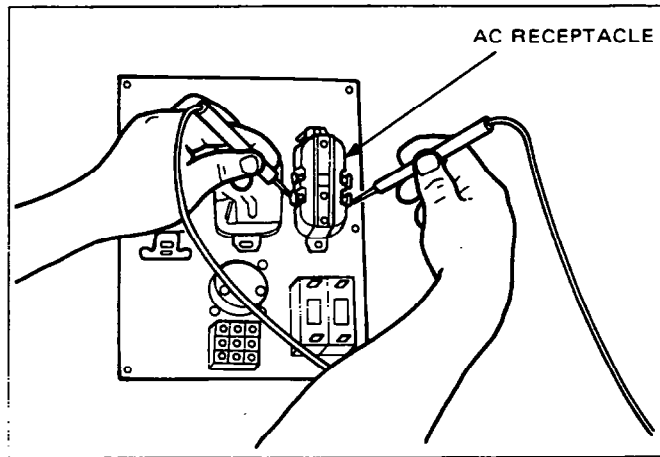

Fig. 9-2B

9-3 CIRCUIT BREAKER

Check continuity between each of two terminals at the rear of the circuit breaker while it is mounted on the control panel. Normally, there is continuity between each of the two when the circuit breaker is on while there is no continuity when the circuit breaker is off.

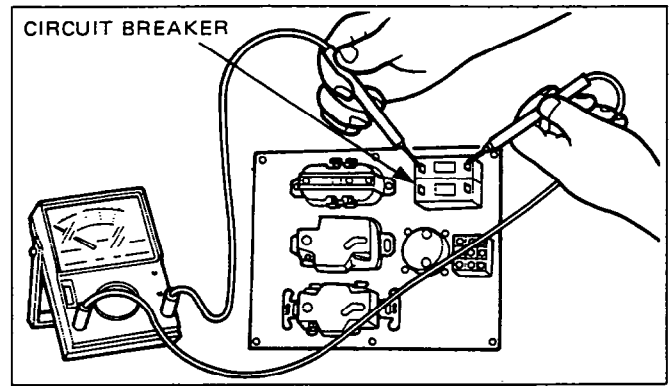

Fig. 9-3

9-4 STATOR

Disengage connectors on the wires from stator and check the resistance between wires with a "Dr. Robin" or a circuit tester referring to the following table.

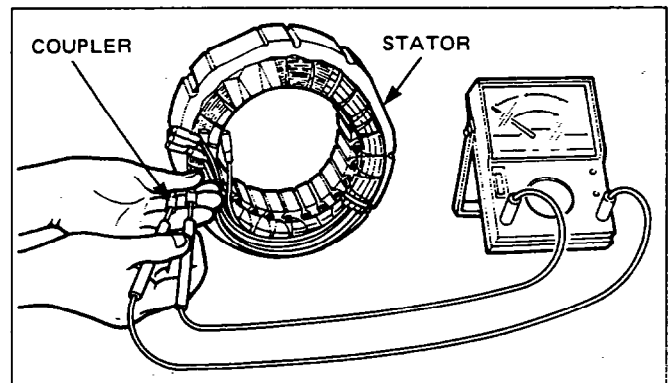

Fig. 9-4

MODEL	Specification		AC Winding		Condenser Winding
	Hz	Voltage	White / Red	Black / Blue	Yellow / Yellow
RGX1800	50	110V, 220V, 110V/220V	1.85	1.85	5.56
		240V	2.10	2.10	5.56
	60	220V, 110V/220V	1.10	1.10	3.80
		120V, 120V/240V	1.10	1.10	3.80
RGX2400	50	110V, 220V, 110V/220V	1.18	1.18	3.34
		240V	1.42	1.42	3.37
	60	220V, 110V/220V	0.84	0.84	2.51
		120V, 120V/240V	0.84	0.84	2.51
RGX3500	50	110V, 220V, 110V/220V	0.73	0.73	1.81
		240V	0.83	0.83	1.83
	60	220V, 110V/220V	0.69	0.69	1.52
		120V, 120V/240V	0.69	0.69	1.52
RGX5500	50	110V, 220V, 110V/220V	0.34	0.34	0.81
		240V	0.41	0.41	0.78
	60	220V, 110V/220V	0.26	0.26	0.58
		120V, 120V/240V	0.26	0.26	0.58

(R×1Ω ±10%)

Table 9-1

NOTE: If the circuit tester is not sufficiently accurate, it may not show the values given and may give erroneous readings.

Erroneous readings will also occur when there is a wide variation of resistance among coil windings or when measurement is performed at ambient temperatures different from 20°C(68°F).

9-5 ROTOR ASSEMBLY

(1) Using a "Dr. Robin" or a circuit tester, measure the resistance of the field coil at the terminals.

MODEL	RGX1800	RGX2400	RGX3500 (50Hz)	RGX3500 (60Hz)	RGX5500
RESISTANCE	2.5 Ω	2.7 Ω	2.1 Ω	2.2 Ω	1.6 Ω

(R×1Ω ±10%)

Table 9-2

NOTE 1: Because a diode is soldered to the coil ends at the terminals, resistance may be measured only when tester probes touche the terminals in one combination of polarity. Therefore, if no resistance reading appears, try checking in reverse polarity.

NOTE 2: If the circuit tester is not sufficiently accurate, it may not show the values given and may give erroneous readings. Erroneous reading will also occur when there is a wide variation of resistance among coil windings or when measurement is performed at ambient temperatures different from 20°C(68°F).

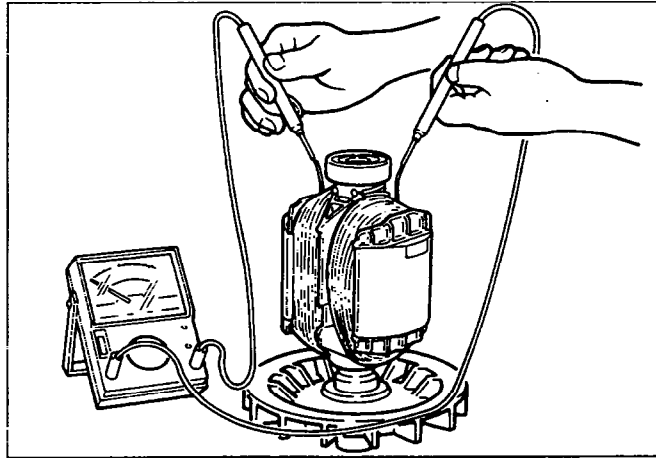

Fig. 9-5

9-6 CONDENSER

■ Use a "Dr. Robin" in capacitance meter mode to check the capacity of condensers. (See Fig.9-6).

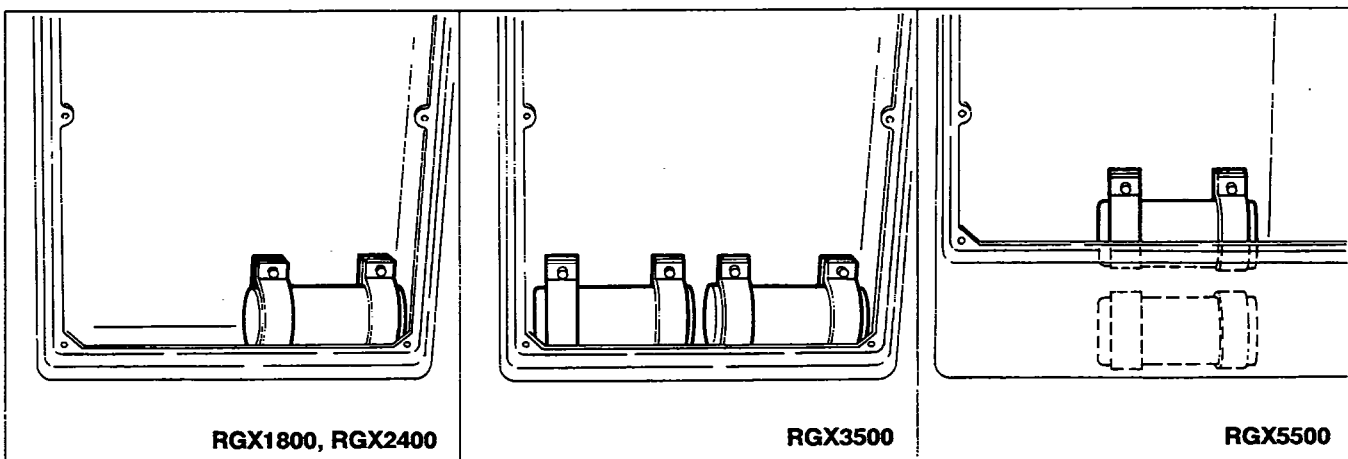

Fig. 9-6

NOTE: Be sure to discharge condensers by shorting condenser leads each other before checking their capacitance, or the accurate reading cannot be obtained.

■ **NORMAL CAPACITY OF CONDENSER**

MODEL		RGX1800	RGX2400	RGX3500	RGX5500
Resistance	①	14 μ F	20 μ F	17 μ F \times 2	28 μ F \times 2
	②	14 μ F	20 μ F	17 μ F \times 2	28 μ F \times 2

Table 9-3

- If such an instrument is unavailable, the condenser can be checked by replacing with a new one. If the generator performs good with new condenser, the cause of trouble is defect in original condenser.

9-7 DIODE RECTIFIER

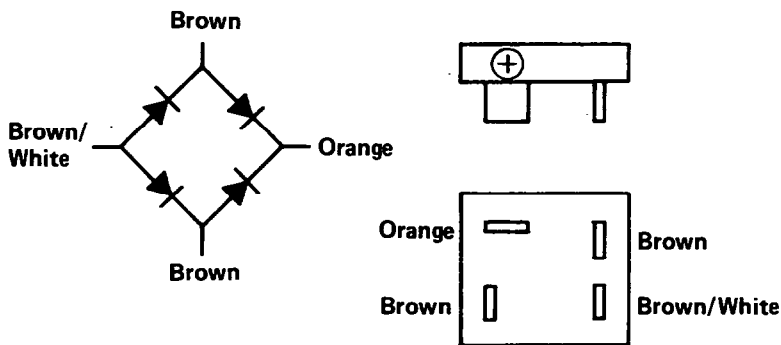

Fig. 9-9

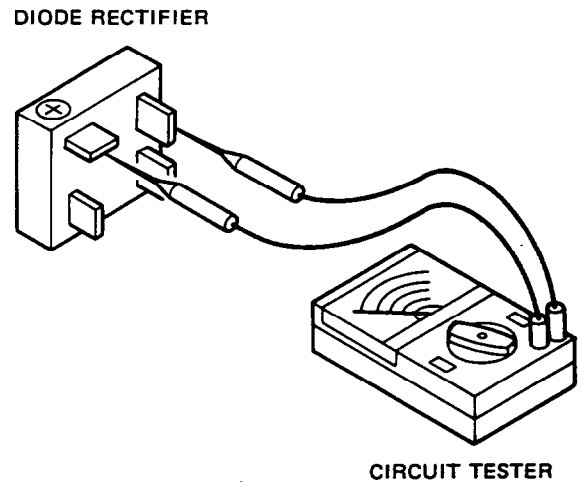

Fig. 9-10

Circuit inside of the diode rectifiers is as shown in Fig. 9-9. Check continuity between each terminal by using a circuit tester as shown in Fig. 9-10. The rectifier is normal when condtnuity is as follows:

- Checking table for analogue circuit tester.

Analogue circuit tester		Apply black \ominus needle of the circuit tester			
		Brown	Brown	Orange	Brown/White
Apply red \oplus needle of the circuit tester	Brown		No continuity	No continuity	Continuity
	Brown	No continuity		No continuity	Continuity
	Orange	Continuity	Continuity		Continuity
	Brown/White	No continuity	No continuity	No continuity	

Table 9-4-1

■ Checking table for digital circuit tester.

Digital circuit tester		Apply red ⊕ needle of the circuit tester			
		Brown	Brown	Orange	Brown/White
Apply black ⊖ needle of the circuit tester	Brown	/	No continuity	No continuity	Continuity
	Brown	No continuity	/	No continuity	Continuity
	Orange	Continuity	Continuity	/	Continuity
	Brown/White	No continuity	No continuity	No continuity	/

Table 9-4-2

NOTE 1: Because of the difference of measuring method between the analogue circuit tester and the digital circuit tester, polarity of tester needles should be reversed.

NOTE 2: "Continuity" means forward direction characteristics of the diode, and different from short circuit condition (in which a pointer of the tester goes out of its normal scale), shows resistance to some extent. When results of the checking indicates failure even in one section, replace with a new one.

NOTE 3: Simpson brand analogue testers are digital.

10. DISASSEMBLY AND ASSEMBLY

10-1 PREPARATION and PRECAUTIONS

- 1) Be sure to memorize the location of individual parts when disassembling the generator so that the generator can be reassembled correctly. Tag the disassembled part with the necessary information to facilitate easier and smoother reassembly.
- 2) For more convenience, divide the parts into several groups and store them in boxes.
- 3) To prevent bolts and nuts from being misplaced or installed incorrectly, place them temporarily back at their original position.
- 4) Handle disassembled parts with care; clean them before reassembly using a neutral cleaning fluid.
- 5) Use all disassembly/assembly tools properly, and use the proper tool for each specific job.

10-2 SPECIAL TOOLS for DISASSEMBLY and ASSEMBLY

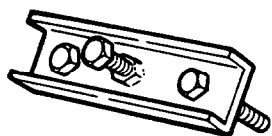

REAR COVER PULLER

10-3 DISASSEMBLY PROCEDURES

Step	Part to remove	Description	Remarks	Tool
1.	Fuel Tank	<p>(1) Discharge fuel from the tank.</p> <ol style="list-style-type: none"> 1. Shut the fuel strainer. 2. Remove the strainer cup. 3. Put a vessel to receive fuel under the strainer and open the fuel cock to discharge fuel. (See Fig. 10-1.) 4. Attach the strainer cup to the strainer body. 	<p>Use utmost care about fire hazard.</p> <p>Wipe off sprit fuel thoroughly.</p> <p>Do not lose the filter screen.</p>	
		<p>(2) Disconnect fuel hose from the strainer. Loosen the hose clamp on top of the strainer and pull out the fuel hose from the strainer. (See Fig. 10-2.)</p>		Pliers
		<p>(3) Take off the four nuts and remove the fuel tank. (See Fig. 10-3.)</p>		13 mm spanner or box wrench

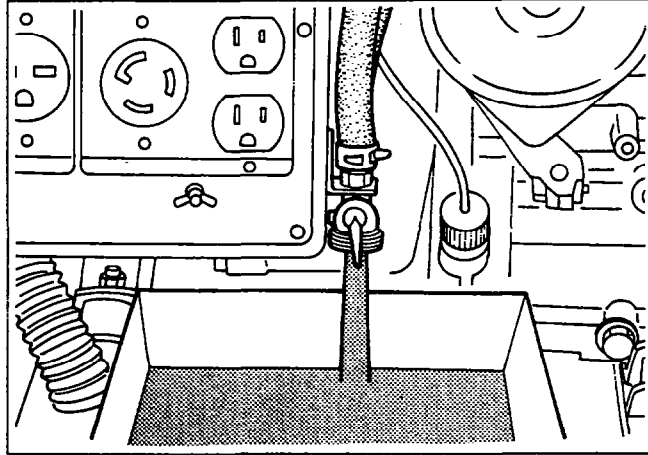

Fig. 10-1

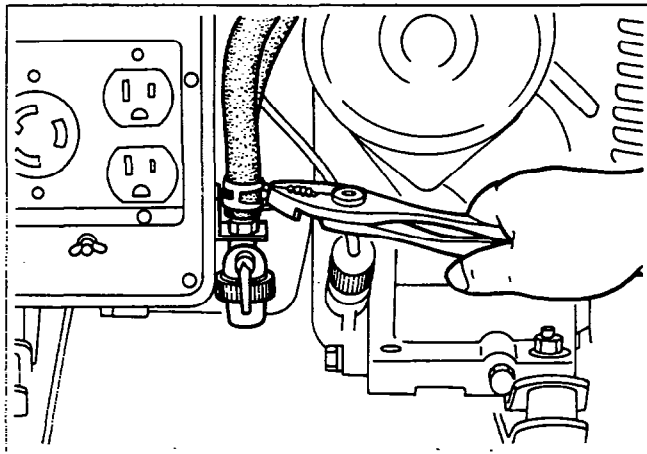

Fig. 10-2

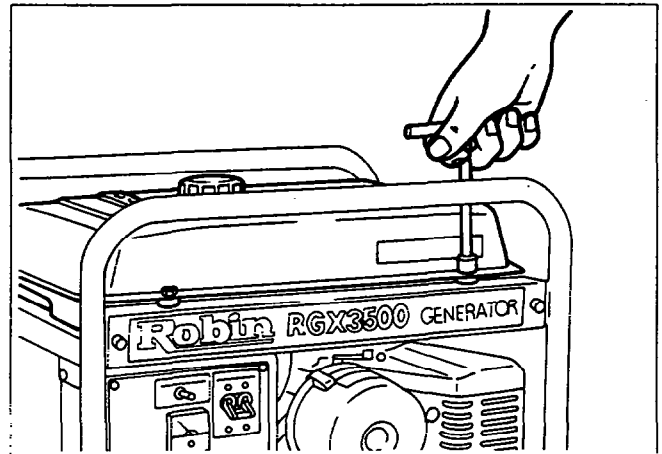

Fig. 10-3

Step	Part to remove	Description	Remarks	Tool
2.	Control Box	(1) Take off the grommet from the rear pannel of control box. (See Fig. 10-4.)		
		(2) Disconnect the connectors on the wiring from the control box to the alternator.		
		(3) Remove the fuel strainer. Remove the nut on top of the fuel strainer located beside the control box. (See Fig. 10-5.)		

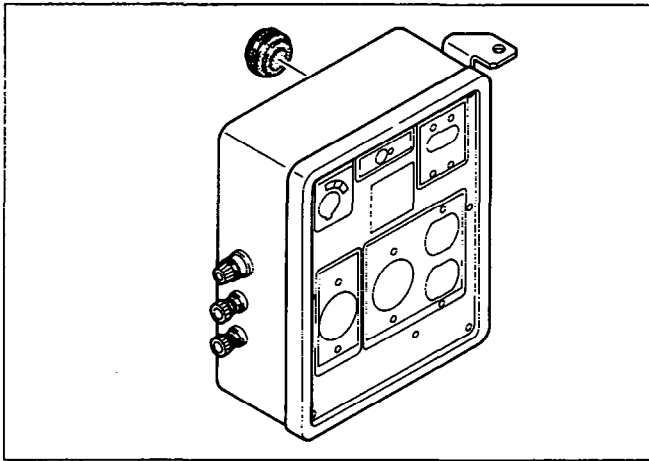

Fig. 10-4

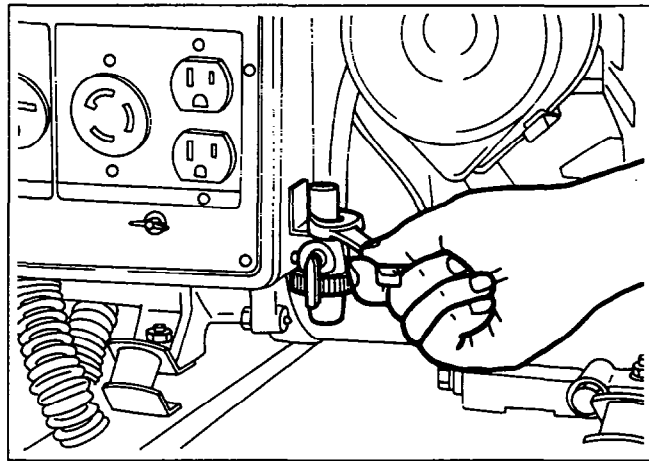

Fig. 10-5

(4) Take off the three bolts and remove the control box from the frame. (See Fig. 10-6.)		10 mm spanner or box wrench
(5) Take off the bushing from the bottom of the control box. (See Fig. 10-7.)	Press the upper end of the bushing and pull out.	

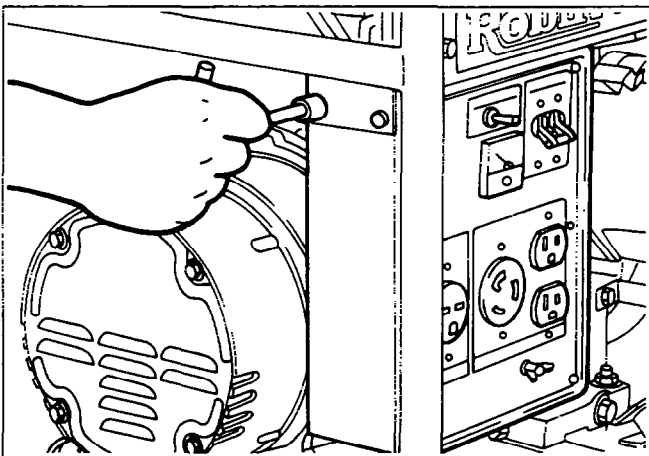

Fig. 10-6

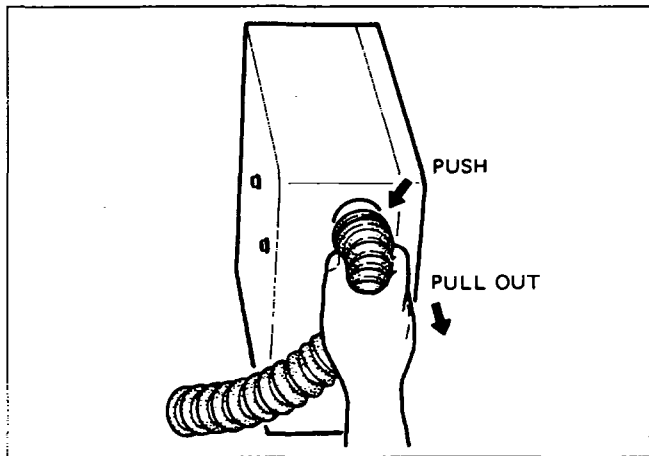

Fig. 10-7

Step	Part to remove	Description	Remarks	Tool
3.	Pipe Frame	(1) Remove SIDE PLATE from frame. (See Fig. 10-8.) 6φ bolt 2 pcs. Remove the mount rubbers from SIDE PLATE.		10 mm spanner or box wrench
		(2) Remove the nuts which fix the engine and alternator on the mount rubbers.		12 mm spanner or box wrench
		(3) Dismount the engine and alternator from the frame.	Take out the engine and alternator assy from the side of the frame. (See Fig. 10-9.)	

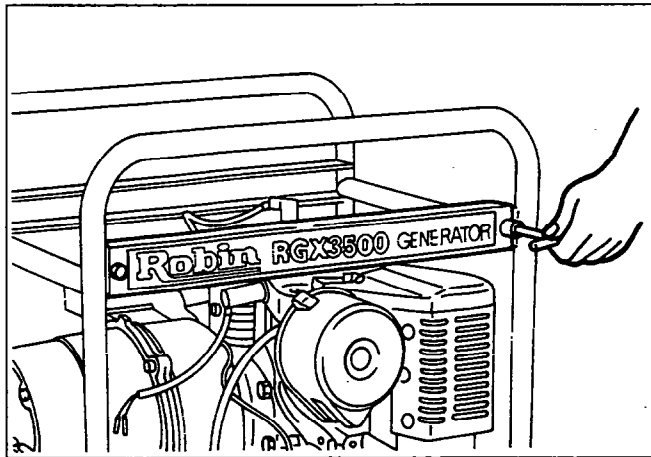

Fig. 10-8

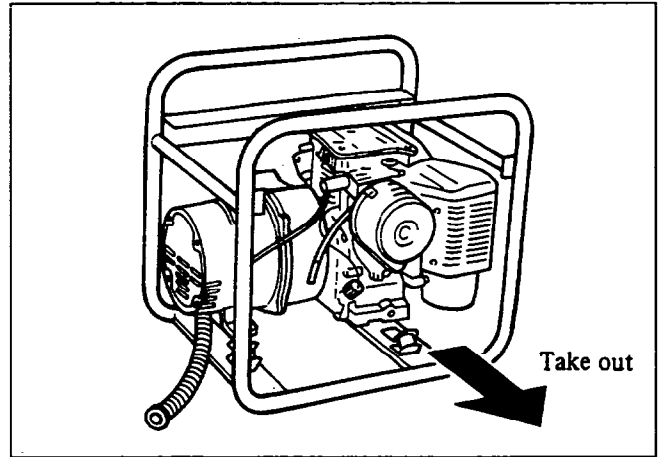

Fig. 10-9

(4) Remove the mount rubbers from frame.
Loosen the nuts on the bottom side of the frame.

12 mm spanner or box wrench

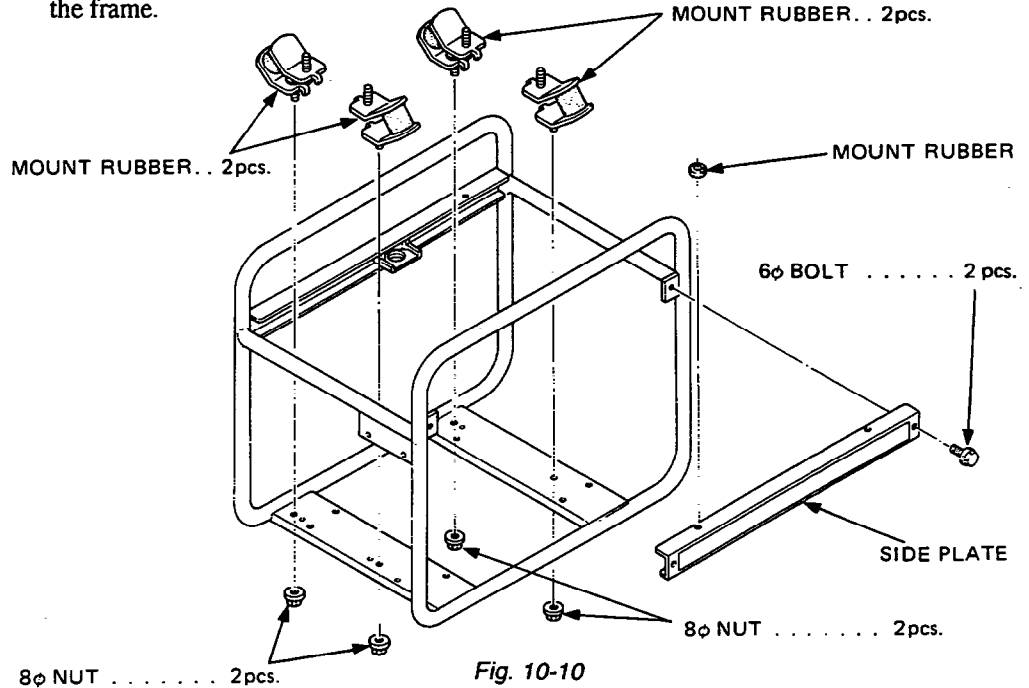

Fig. 10-10

Step	Part to remove	Description	Remarks	Tool
4.	Rear Cover	(1) Remove the end cover. (See Fig. 10-11.) 6φ bolt 4 pcs.		10 mm spanner or box wrench
		(2) Take off the rear cover. 1. Remove the four bolts which fasten the rear cover to the front cover. 6φ bolt 4 pcs. 2. Use a special tool "REAR COVER PULLER" to remove the rear cover. a) Insert the two screws of the special tool into the thread holes of the rear cover. b) Apply the center bolt of the special tool on the head of the through bolt. c) Tighten the center bolt to pull out the rear cover.	Insert the two screws sufficiently and evenly, or the thread hole may be damaged at removing.	10 mm spanner or box wrench

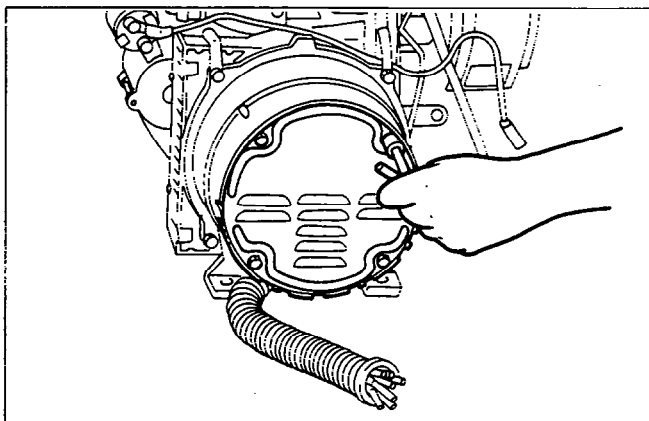

Fig. 10-11

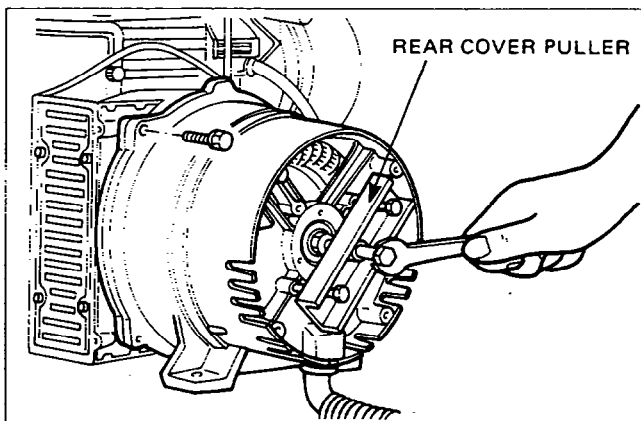

Fig. 10-12

In the case that "REAR COVER PULLER" is unavailable, remove the rear cover by the following instructions.

2'. Hit on the boss and legs of rear cover with a plastic hammer to loosen.

Do not give a strong hit on the boss or legs.

Box wrench
Plastic hammer

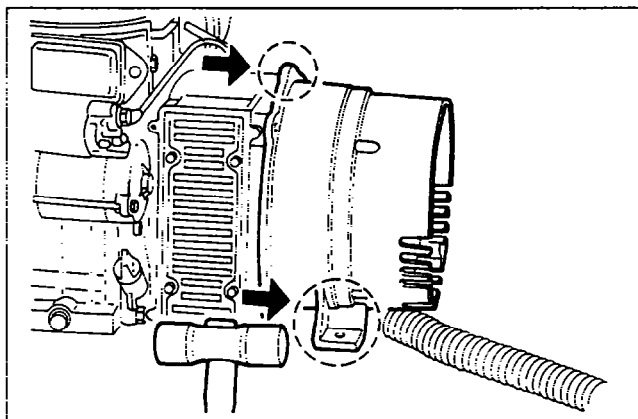
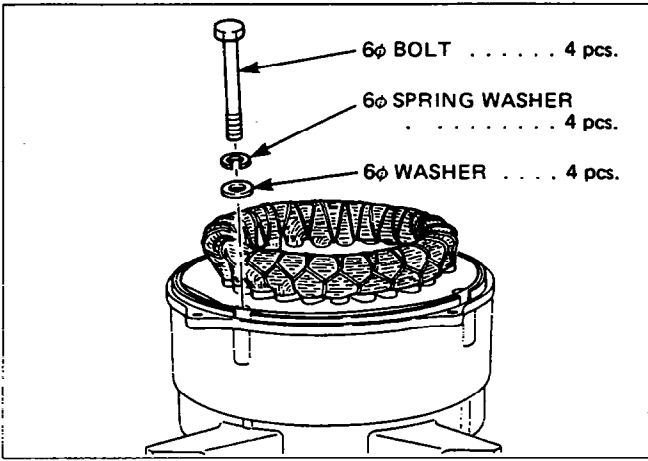

Fig. 10-13

Step	Part to remove	Description	Remarks	Tool
5.	Stator	<p>(1) Remove the four bolts which fasten the stator to the rear cover. (See Fig. 10-14.)</p>  <p style="text-align: center;">Fig. 10-14</p>		10 mm socket wrench
		<p>(2) Put a piece of lumber on the floor in upright position. (See Fig. 10-15.)</p>		
		<p>(3) Hold the rearcover and stator upside down with both hands.</p>		
		<p>(4) Down the rear cover and stator over the lumber lightly hitting the bottom of rear cover to the top end of lumber to pull out the stator. (See Fig. 10-16.)</p>		
<p>[NOTES]</p> <ol style="list-style-type: none"> 1. Apply fingers to stator coil to keep the stator from dropping on the floor. 2. Gently hit the bottom of rear cover to the top end of lumber several times until the stator comes out loose. 				

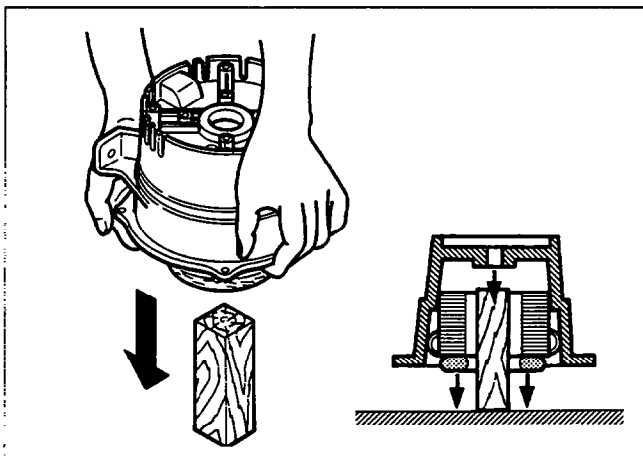

Fig. 10-15

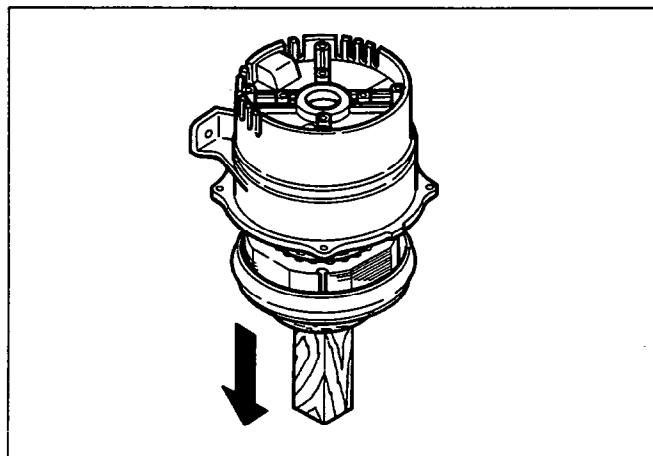
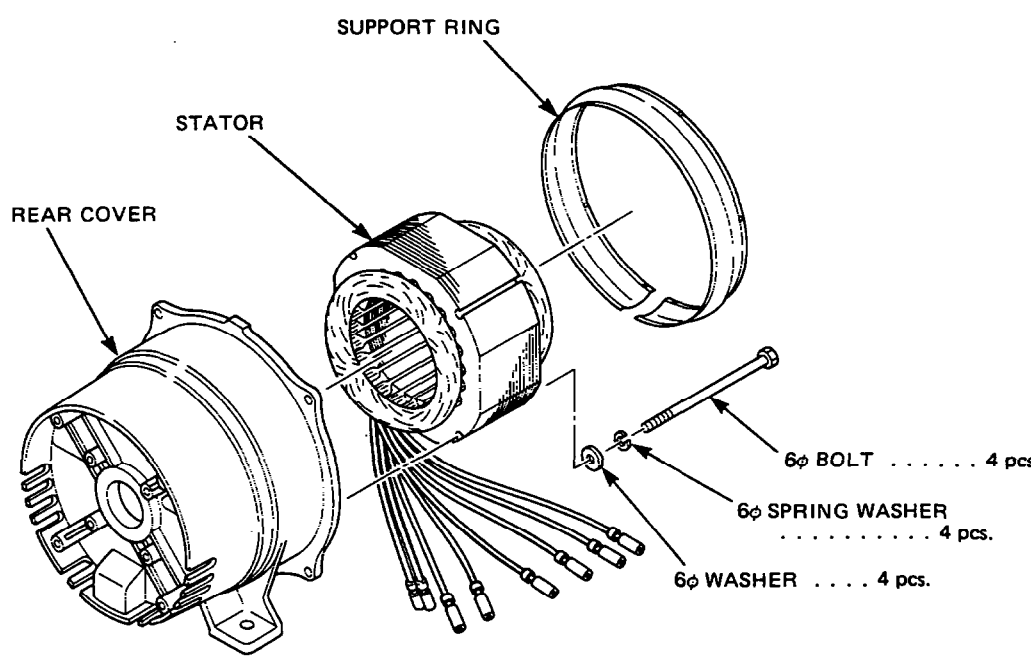
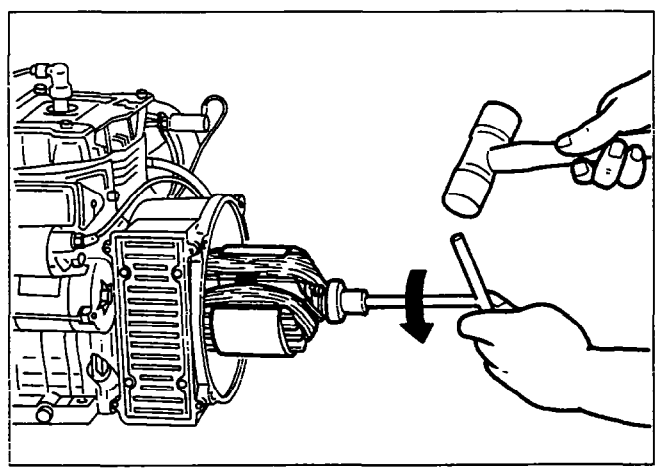

Fig. 10-16

Step	Part to remove	Description	Remarks	Tool
5.	Stator	<p>(5) Take apart the support ring and stator from rear cover.</p>  <p style="text-align: center;">Fig. 10-17</p>		
6.	Rotor	<p>(1) Take off the through bolt. Apply a box wrench on the head of through bolt. Hit the wrench handle with a hammer counter-clockwise to loosen.</p>  <p style="text-align: center;">Fig. 10-18</p> <p>(2) Put the engine on the working table recoil starter side down.</p>		<p>Box wrench Plastic hammer</p>

Step	Part to remove	Description	Remarks	Tool
6.	Rotor	<p>(3) Use a bolt and oil as a tool for pulling out rotor in the following procedures :</p> <ol style="list-style-type: none"> 1. Pour engine oil into the center hole of rotor shaft. Fill with oil to the shaft end. (See Fig. 10-19.) 2. Prepare a bolt with the following thread size: RGX1800, 2400, 3500 ··· M10×P1.25 RGX5500 ········· M12×P1.50 3. Apply a few turns of seal tape around the tip of the bolt. (See Fig. 10-20.) 		

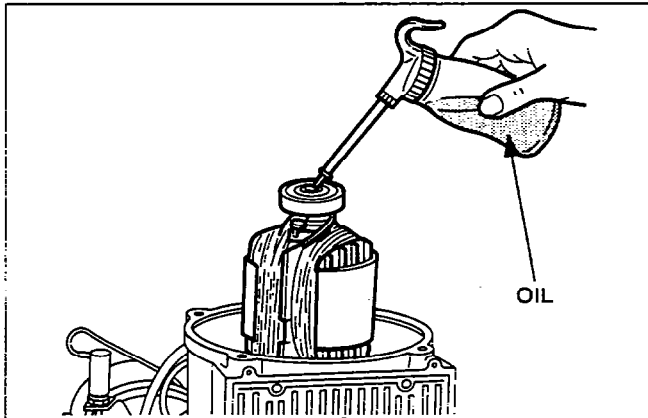

Fig. 10-19

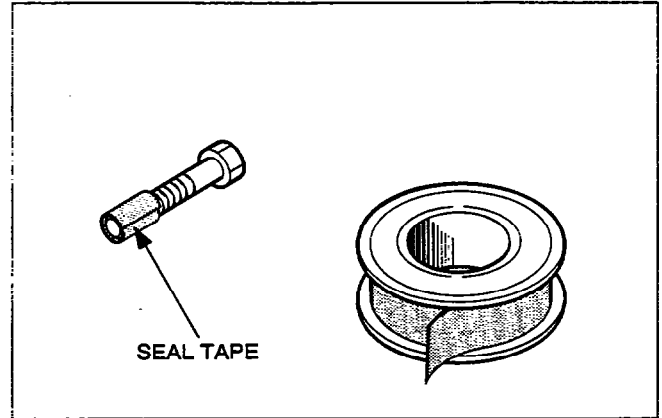
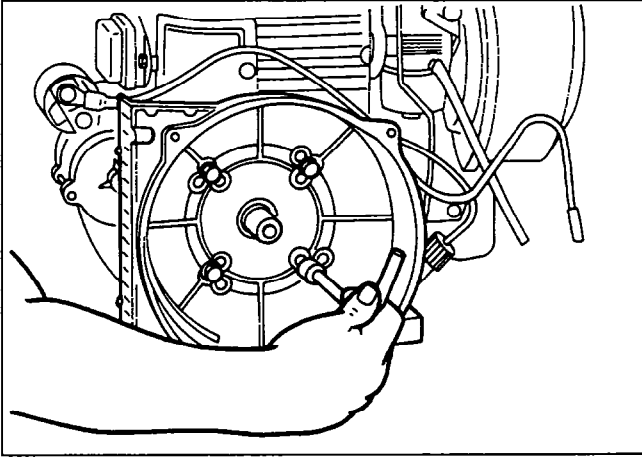

Fig. 10-20

		<ol style="list-style-type: none"> 4. Screw the bolt into the thread of the rotor shaft. 5. Torque the bolt using a socket wrench until the rotor comes off loose. * The hydraulic pressure inside the rotor shaft takes apart the rotor from the engine shaft. 		Socket wrench
--	--	---	--	---------------

		<p>(4) Wipe off oil thoroughly from rotor shaft and engine PTO shaft.</p>		

Fig. 10-21

Step	Part to remove	Description	Remarks	Tool
7.	Front Cover	<p>(1) Remove the front cover. Loosen the four bolts and remove the front cover. 8ϕ bolt 4 pcs.</p>  <p style="text-align: center;">Fig. 10-22</p>		12 mm Socket wrench

10-4 ASSEMBLY PROCEDURES

10-4-1 FRONT COVER

Attach the front cover to the engine main bearing cover. Match the faucet joint and tighten the bolts.

M8 × 18mm bolt 4 pcs.

M8 spring washer 4 pcs.

Tightening torque : 120 ~ 140 kg-cm
8.7 ~ 10.1 ft·lbs.

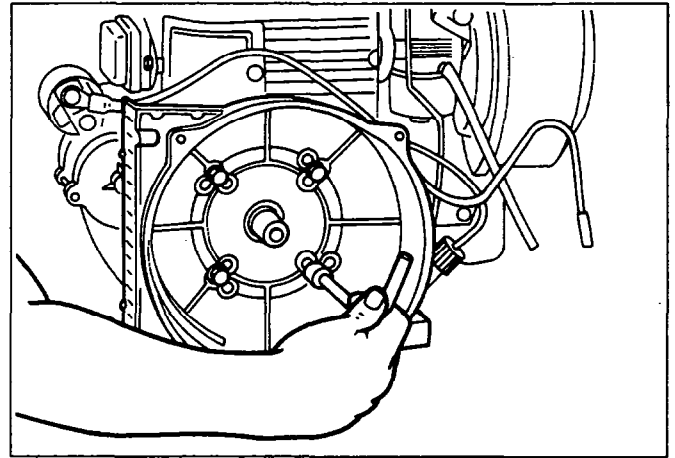

Fig. 10-23

10-4-2 ROTOR

(1) Wipe off oil, grease and dust from the tapered portion of engine shaft and matching tapered hole of rotor shaft.

(2) Mount the rotor to the engine shaft.

Tighten the through bolt.

Apply a wrench on the through bolt and hit wrench handle clockwise with a hammer to tighten.

If an impact wrench is available, use it.

Tightening torque :

RGX1800, 2400 : 115 ~ 135 kg-cm
8.7 ~ 10.8 ft·lbs.

RGX3500, 5500 : 230 ~ 250 kg-cm
16.6 ~ 19.5 ft·lbs.

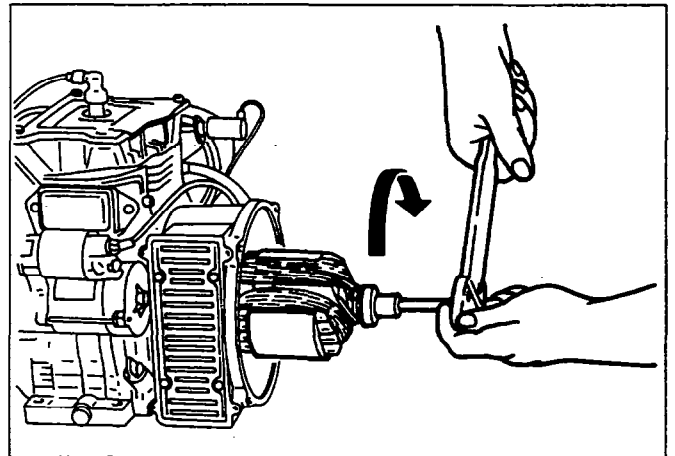

Fig. 10-24

10-4-3 STATOR

(1) Put the stator in the rear cover setting the four grooves on the side of stator with thread holes of the rear cover.

Tighten the four bolts tentatively to check if the grooves and thread holes are aligned correctly. (See Fig.10-25.)

(2) Remove the four bolts.

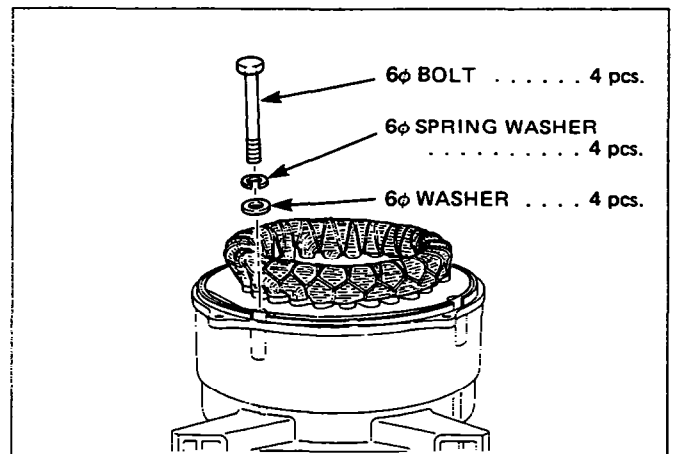

Fig. 10-25

(3) Apply the support ring between the rear cover and the stator.

Tap on the support ring evenly using an aluminum bar and a hammer to press into the rear cover. (See Fig.10-26.)

CAUTION: Be careful of the position of hooking holes of the support ring.

(4) Join the stator to rear cover with four bolts, washers and spring washers. (See Fig.10-25.)

M6 bolt 4 pcs.

M6 washer 4 pcs.

M6 spring washer 4 pcs.

Tightening torque : 80 ~ 100 kg·cm

5.8 ~ 7.2 ft· lbs.

NOTE : Tighten four bolts evenly taking several steps.

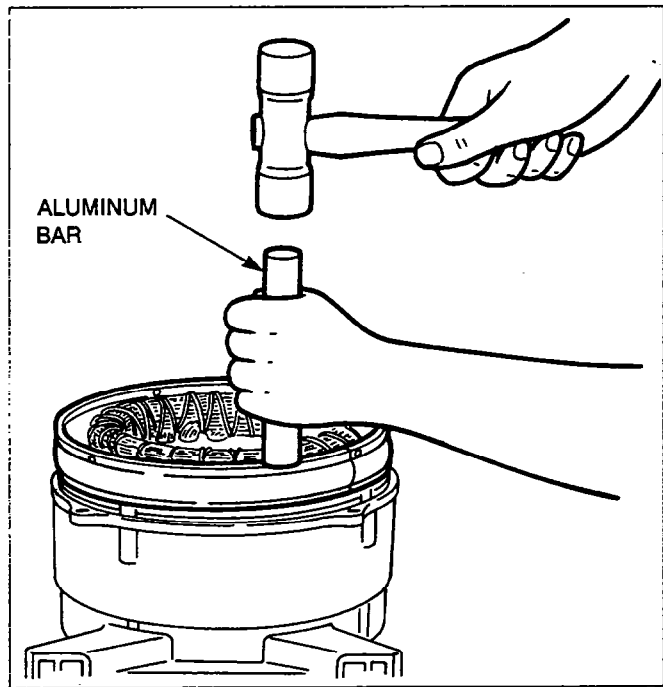
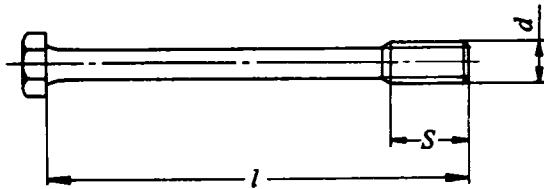

Fig. 10-26

• The dimensions of the stator bolts are shown in Table 10-1.



MODEL	<i>l</i>	<i>s</i>	<i>d</i>
RGX1800	65 mm 25.6 inch	65 mm 25.6 inch	M8 × 1.25
RGX2400	75 mm 29.5 inch	15 mm 0.59 inch	M8 × 1.25
RGX3500 (50Hz)	85 mm 3.35 inch	85 mm 3.35 inch	M8 × 1.25
RGX3500 (60Hz)	90 mm 3.54 inch	25 mm 0.98 inch	M10 × 1.5
RGX5500	115 mm 4.53 inch	40 mm 1.57 inch	M10 × 1.5

Table 10-1

10-4-4 REAR COVER

- (1) Attach the bushing over the lead wire drawn out from the rear cover.
Press the smaller end of the bushing into the window of the rear cover. (See Fig.10-27.)

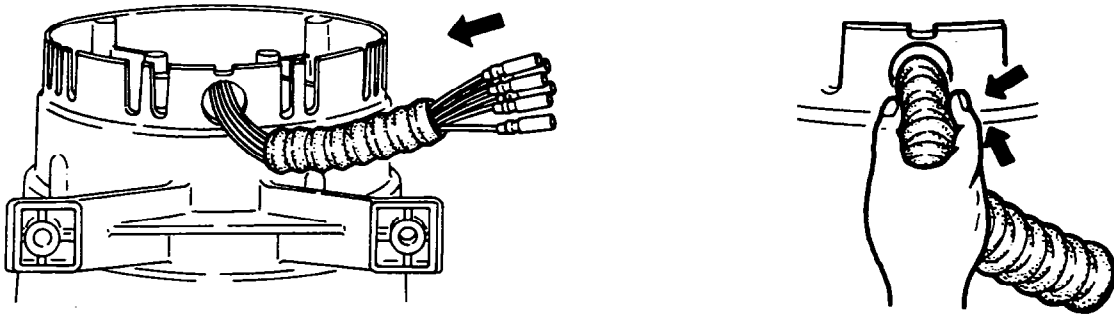

Fig. 10-27

- (2) Put the rear cover with stator over the rotor.
Tap on the rear cover evenly with a plastic hammer to press the rotor bearing into the rear cover.

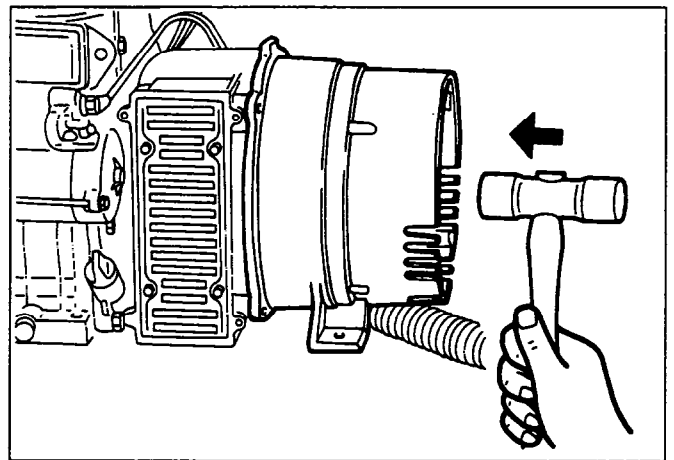

Fig. 10-28

- (3) Fix the rear cover to the adaptor with four bolts, spring washers, and washers.

M6 × 25 mm bolt 4 pcs.

M6 spring washer 4 pcs.

M6 washer 4 pcs.

Tightening torque : 50 ~ 60 kg-cm
3.6 ~ 4.3 ft·lbs.

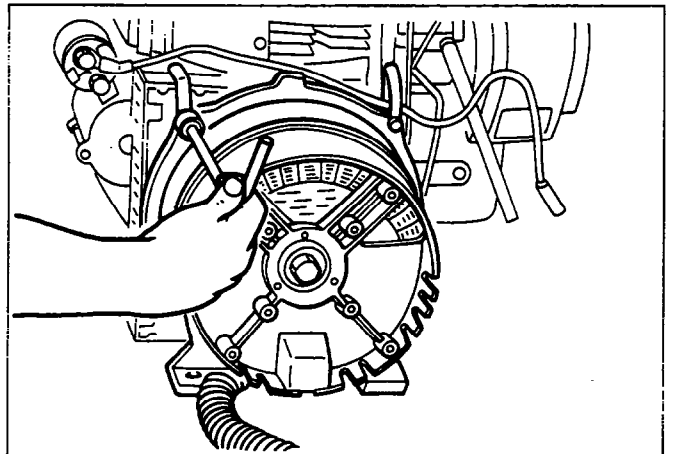

Fig. 10-29

10-4-5 END COVER

Attach the end cover to the rear cover.

M6 × 8mm flange bolt 4 pcs.

Tightening torque : 40 ~ 60 kg-cm
2.9 ~ 4.3 ft·lbs.

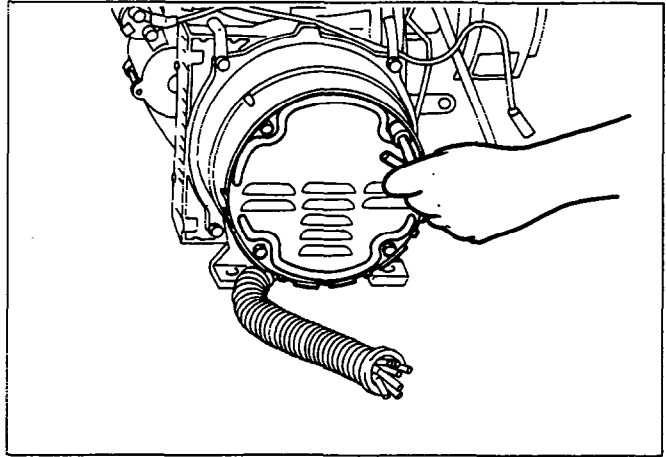

Fig. 10-30

10-4-6 FRAME

(1) Attach the mount rubbers to the frame.

Insert the setting tongue of mount rubber into the hole on the frame and tighten the nut from the bottom of the frame.

M8 flange nut 4 pcs.

Tightening torque : 120 ~ 140 kg-cm
8.7 ~ 10.8 ft·lbs

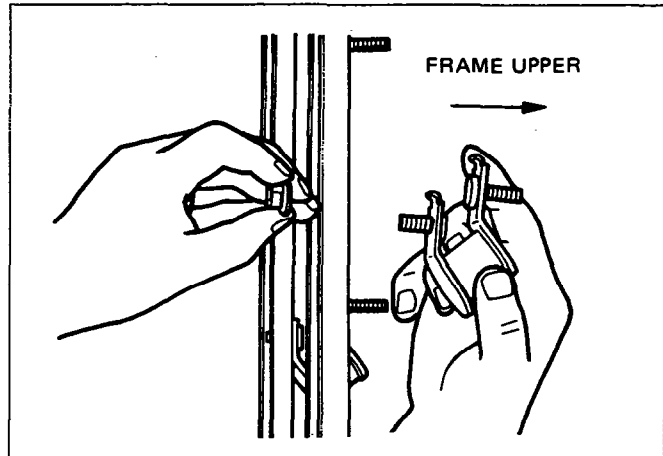

Fig. 10-31

NOTE : The mount rubbers are selected to reduce vibration most effectively by model and its frequency.

Be sure to use the correct mount rubber for your generator.

Although mount rubbers have the same appearance, their characteristics are different.

(2) Attach the 5φ terminal of the grounding wires (green/yellow) to the unpainted thread hole of the frame base plate using a 5 mm brass screw.

- (3) Install the engine and alternator assembly into the frame.
 Put the engine and alternator assembly into the frame from the side of it.
 Tighten the nuts over the mount rubber bolts to fix.

M8 nuts

Tightening torque : 120 ~ 140 kg-cm
 8.7 ~ 10.1 ft-lbs.

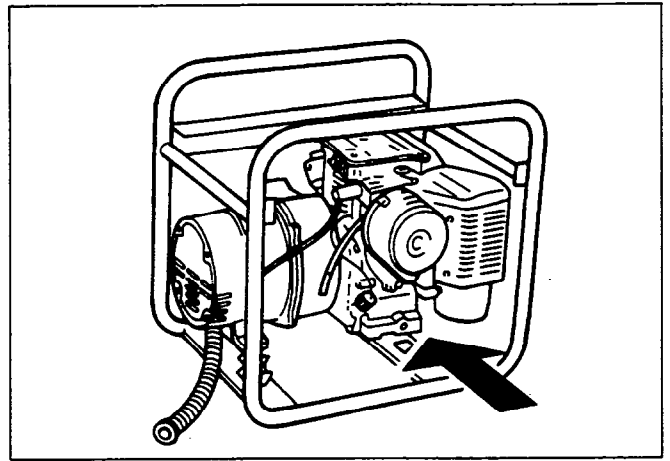

Fig. 10-32

NOTE : When tightening the nuts, slightly lift the engine and alternator assembly so that the weight is not applied to the mount rubbers.

- (4) Attach the side plate frame.
 M6 × 10 mm bolt 2 pcs.
 Attach fuel tank mount rubbers to side plates.
 The nuts for mount rubbers are welded to side plates.
 Tightening torque : 40 ~ 60 kg-cm
 2.9 ~ 4.3 ft-lbs.

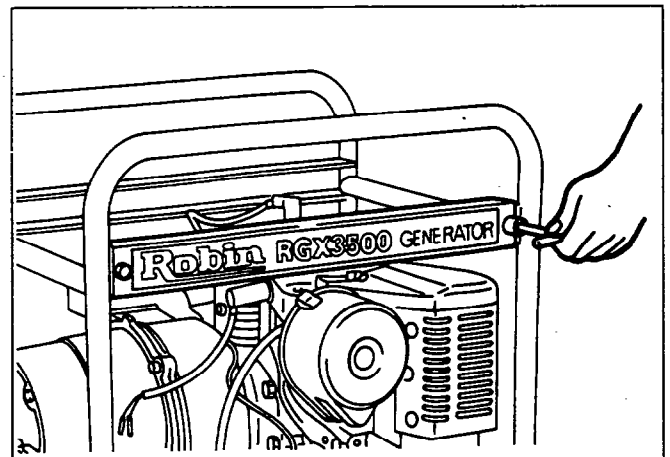

Fig. 10-33

10-4-7 CONTROL BOX

Mount the control box assembly to the frame.
 Refer to Section 10-5 for disassembly, checking and reassembly procedures of the control box.

- (1) Attach the 4 ϕ terminal of the grounding wires to the rear panel of the control box.
 M4 nut (brass) 1 pce.
- (2) Connect the wires drawn out from the stator to the wires from the control box.
 Connect the oil sensor wires at the same time.

NOTE : Connect the wires of the same color.

- (3) Press the upper end of the bushing into the bottom window of the control box.

Attach the grommet for the oil sensor wires to the rear panel of the control box.

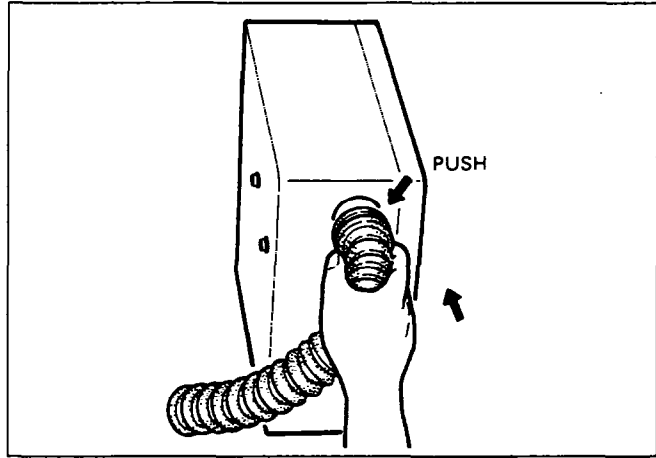

Fig. 10-34

- (4) Mount the control box to the frame.

M6 × 12 mm flange bolt 3 pcs.

Tightening torque : 40 ~ 60 kg-cm
2.9 ~ 4.3 ft-lbs.

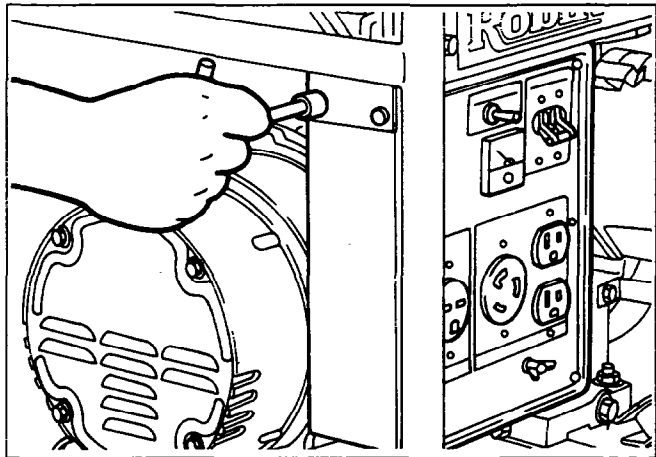

Fig. 10-35

- (5) Fasten the one earth cable with 8φ terminal drawn out from the control box to the rear cover leg.

M8 nut 1 pce.

Tightening torque : 80 ~ 100 kg-cm
5.8 ~ 7.2 ft-lbs.

Fasten the other earth cable with 5φ terminal to the unpainted bolt hole on the frame. (See Fig.10-36.)

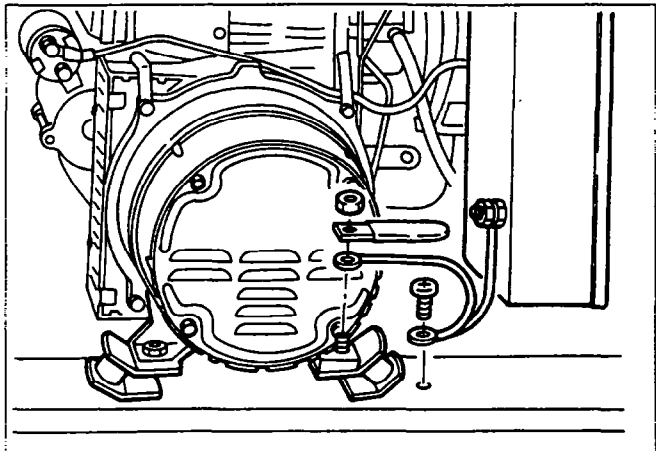
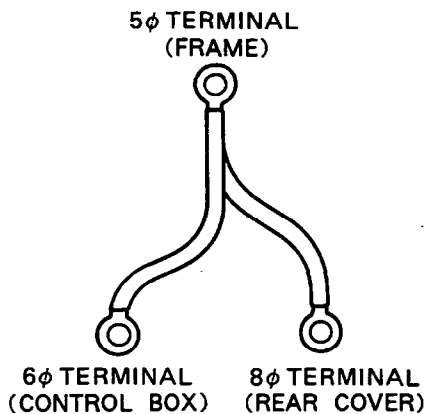

Fig. 10-36

10-4-8 FUEL TANK

- 1) Connect the rubber pipe to the engine carburetor and fasten it with a hose clamp. Attach the banjo to the opposite end of the rubber pipe, tighten it with a hose clamp, and fasten the pipe to the fuel strainer with the banjo bolt.
- 2) Fasten the strainer to the strainer bracket with the joint nuts.
- 3) Mount the fuel tank on the side plates with rubber washers between them.
M6 ×20 mm black bolts4 pcs.
M6 washers4 pcs.
M6 spring washers4 pcs.

NOTE : For easy tank assembly, glue the rubber washers over the holes on the side plates.

- 4) Connect the rubber pipe
First, fit the hose clamps on the rubber pipe, connect the strainer and fuel tank, then fasten the rubber pipe with the hose clamps.

NOTE : Apply a drop of oil to the rubber pipe so that it may easily be connected to the strainer and the fuel tank.

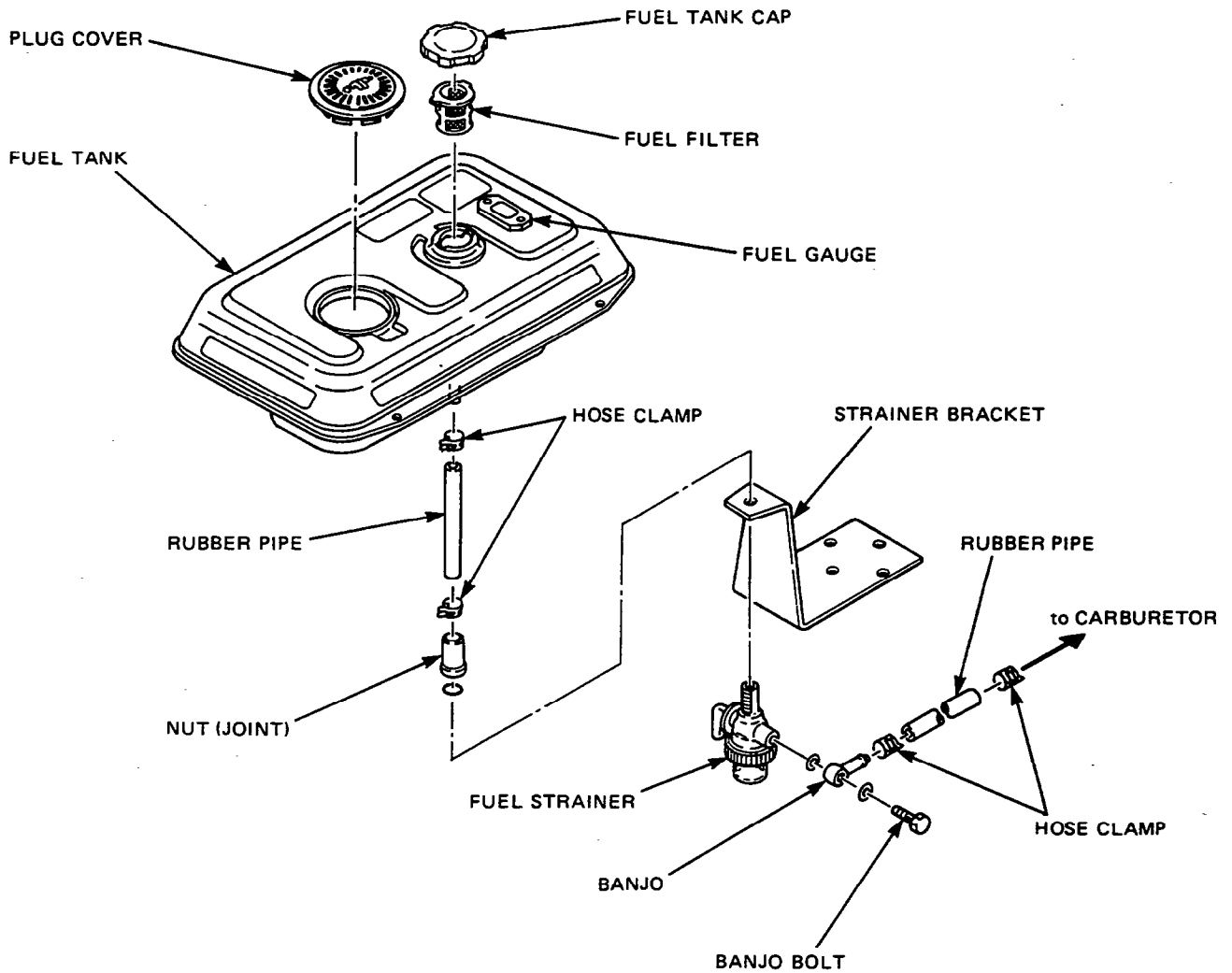

Fig. 10-37

10-5 CHECKING, DISASSEMBLY and REASSEMBLY of the CONTROL BOX

10-5-1 CHECKING OF THE CONTROL BOX

Dismount the control box from frame.

Remove the control panel and check each components and wiring.

Refer to Section 9 for the detail of checking procedure for the components in the control box.

10-5-2 DISASSEMBLY

(1) Remove the control panel from the control box.

M4 screw 6 pcs. (RGX1800, RGX2400, RGX3500)

M4 screw 8 pcs. (RGX5500)

(2) Disconnect the connectors on the wires to detach the control panel and box.

(3) Remove the condensers and diode rectifier from the control box.

(4) After disconnecting individual wires, remove the control panel components.

NOTE: DC fuse, full power switch and pilot lamp have their wires soldered. Unsolder them to remove those parts if necessary.

10-5-3 REASSEMBLY

(1) Install the receptacles, no-fuse breaker, fuse, terminals, switches, etc. on the control panel and wire them.

NOTE: Circuit diagrams are shown in Section 12. Colored wires are used for easy identification, and are of the correct capacity and size. Use heat-resistant type wires (permissible temperature range 75°C or over) in the specified gauge shown in the circuit diagrams.

(2) Install condensers, and diode rectifier into the control box.

(3) Connect the wires of control panel components and control box.

Fasten the earth wires to the rear of the control box using a M4 nut to the bolt which fixes the condenser bracket to the inside of the control box. (See Fig.10-38.)

(4) Attach the control panel to the control box.

M4 screw 6 pcs. (RGX1800, RGX2400, RGX3500)

M4 screw 8 pcs. (RGX5500)

Tightening torque 12 ~ 15 kg-cm

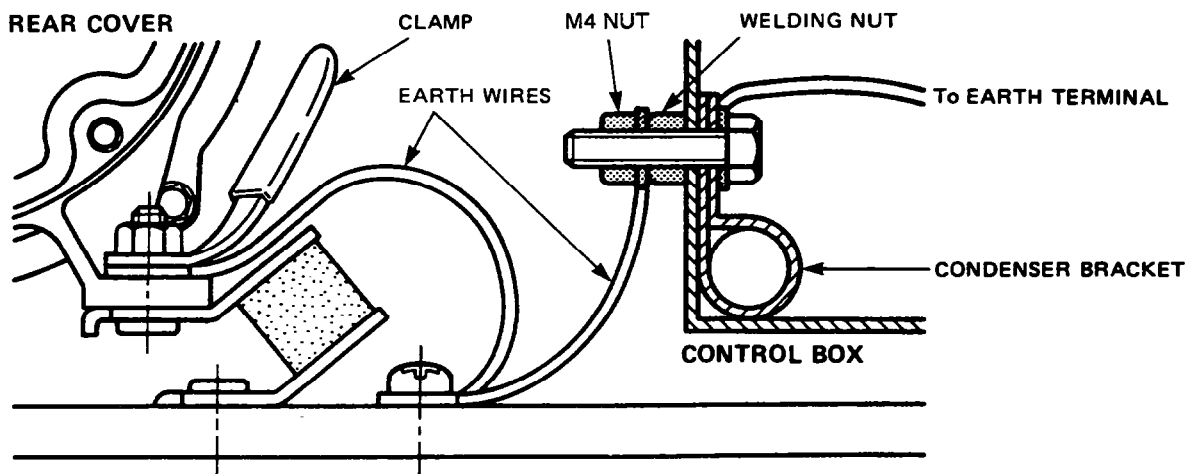

Fig. 10-38

11. TROUBLESHOOTING

11-1 NO AC OUTPUT

11-1-1 CHECKING CONDENSER

Check the capacity of condensers using a "Dr. Robin" generator tester in capacitance meter mode.

NOTE : Be sure to discharge condensers by shorting condenser leads each other before checking their capacitance, or the accurate reading cannot be obtained.

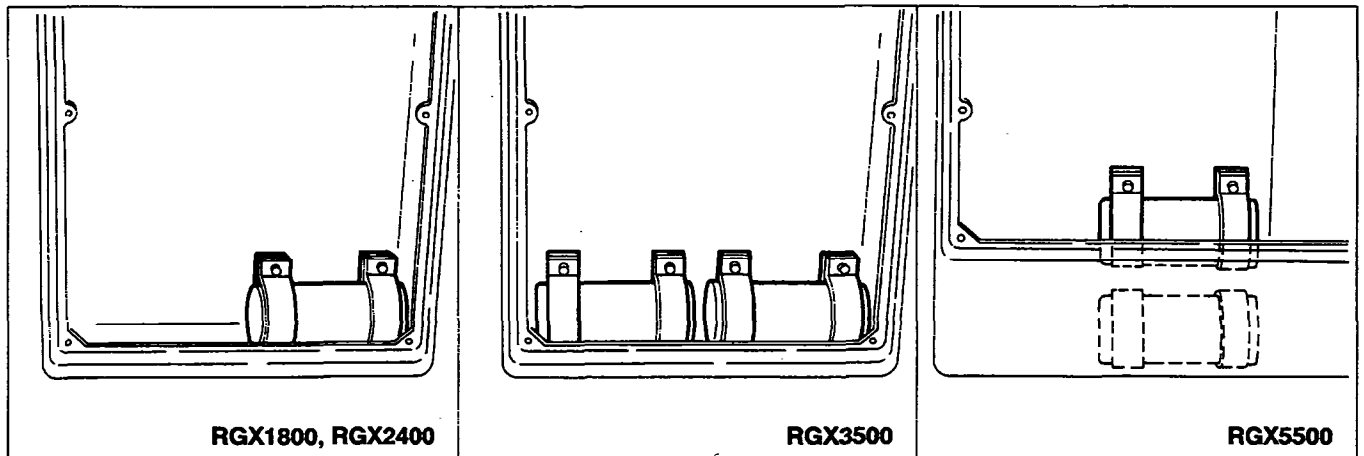

Fig. 11-1

■ NORMAL CAPACITY OF CONDENSER

MODEL	RGX1800	RGX2400	RGX3500	RGX5500
CAPACITY	14 μ F	20 μ F	17 μ F \times 2	28 μ F \times 2

Table 11-1

- If such an instrument is unavailable, the condenser can be checked by replacing with a new one. If the generator performs good with new condenser, the cause of trouble is defect in original condenser.

11-1-2 CHECKING STATOR

- Remove control panel and disconnect stator wires at the connectors.
- Measure the resistance between terminals on stator leads. (See Fig.11-2)
Refer to Table 9-1 for normal resistance.
If stator is faulty, replace it with a new one.

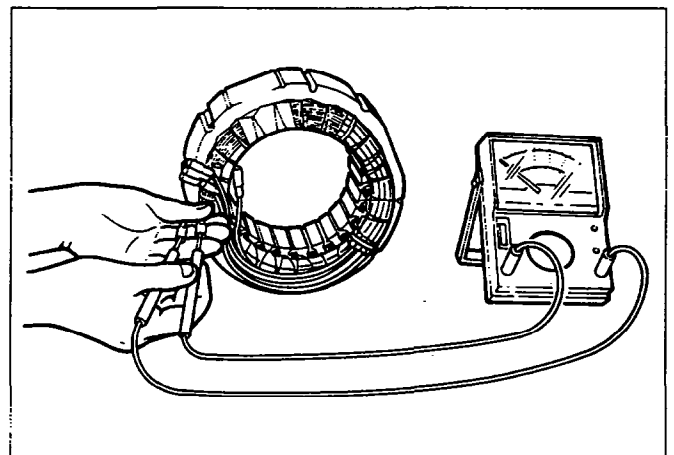

Fig. 11-2

- Check the insulation resistance between stator core and each stator lead using a Dr. Robin generator tester in megger tester mode or a megger tester. (Fig. 11-3)
If insulation is bad, replace stator with a new one.

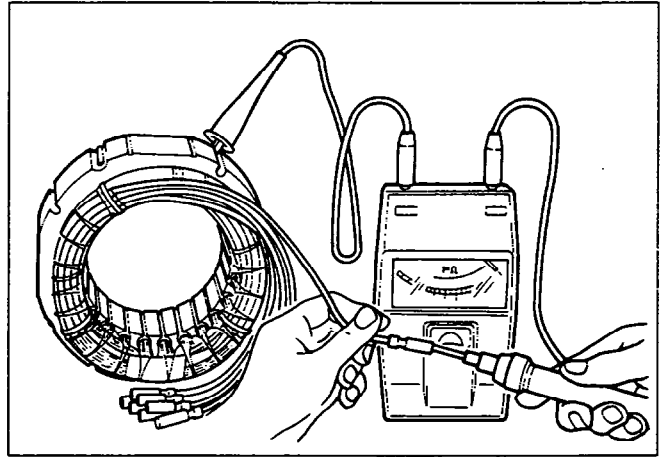

Fig. 11-3

11-1-3 CHECKING ROTOR

(1) CHECKING FIELD COIL

- Remove rear cover and stator.

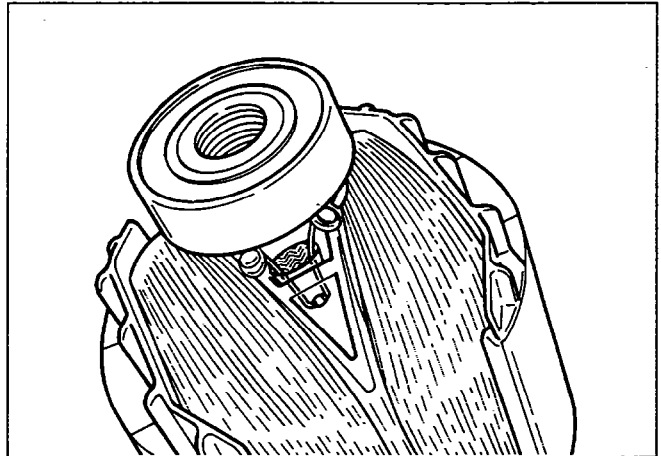

Fig. 11-4

- Using a Dr. Robin or a circuit tester, measure the resistance of the field coil at the terminals.

($R \times 1\Omega \pm 10\%$)

MODEL	RGX1800	RGX2400	RGX3500 (50Hz)	RGX3500 (60Hz)	RGX5500
RESISTANCE	2.5 Ω	2.7 Ω	2.1 Ω	2.2 Ω	1.6 Ω

Table 11-2

NOTE 1 : Because a diode is soldered to the coil ends at the terminals, resistance may be measured only when tester probes touch the terminals in one combination of polarity. Therefore, if no resistance reading appears, try checking in reverse polarity.

[Remedy]

If the resistance is not normal, replace rotor with a new one.

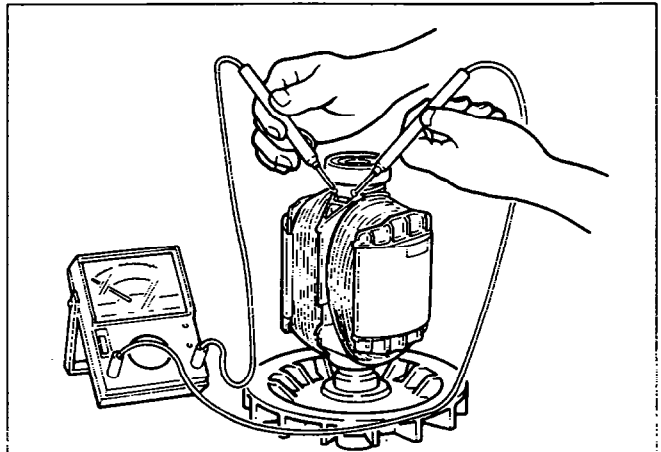

Fig. 11-5

- Measure the insulation across one of the soldered terminals of the rotor and the core. (Fig.11-6)

If insulation is bad, replace rotor with a new one.

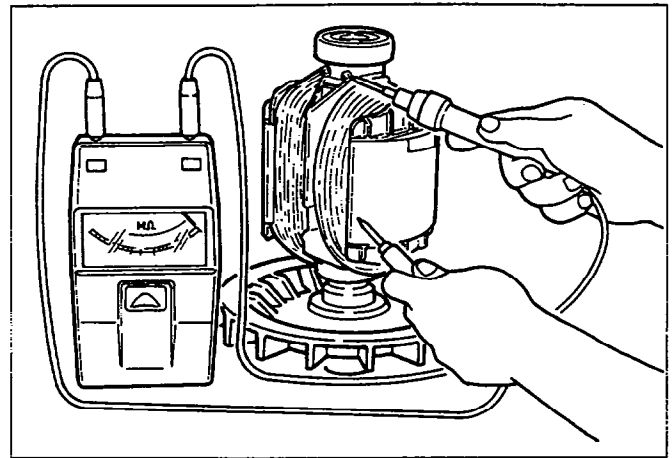

Fig. 11-6

11-2 AC VOLTAGE IS TOO HIGH OR TOO LOW

11-2-1 CHECKING ENGINE SPEED

If the engine speed is too high or too low, adjust it to the rated r.p.m.

[How to adjust engine r.p.m.]

- Loosen the lock nut on the adjusting screw.
- Turn the adjusting screw clockwise to decrease engine speed or counter-clockwise to increase engine speed.

Normal engine speed at no load is :

- 3100 ~ 3150 r.p.m. for 50Hz type
- 3700 ~ 3750 r.p.m. for 60Hz type

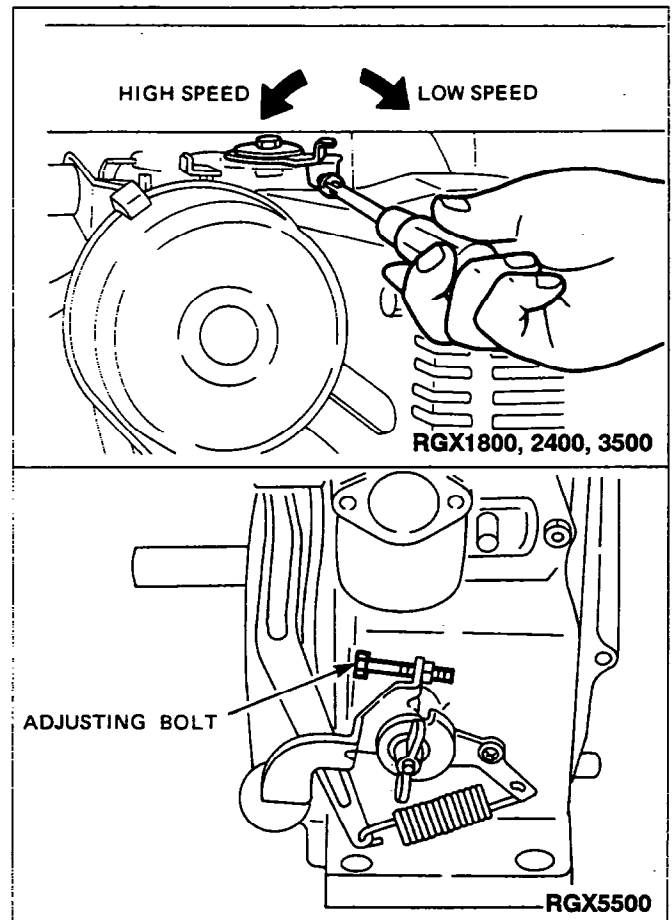

Fig. 11-7

11-2-2 CHECKING CONDENSER

Check condenser referring to Step 11-1-1.

11-2-3 CHECKING STATOR

Check stator referring to Step 11-1-2.

11-2-4 CHECKING ROTOR

Check rotor referring to Step 11-1-3.

11-3 AC VOLTAGE IS NORMAL AT NO-LOAD, BUT THE LOAD CANNOT BE APPLIED.

11-3-1 CHECK THE ENGINE SPEED.

If the engine speed is low, adjust it to the rated r.p.m.

* Refer to Step 11-2-1 for engine speed adjustment.

11-3-2 CHECK THE TOTAL WATTAGE OF APPLIANCES CONNECTED TO THE GENERATOR.

Refer to Section 7 "RANGE OF APPLICATIONS" for the wattage of the appliances.

If the generator is over-loaded, reduce the load to the rated output of the generator.

11-3-3 CHECK THE APPLIANCE FOR TROUBLE.

If the appliance is faulty, repair it.

11-3-4 CHECK IF THE ENGINE IS OVER-HEATED.

If the cooling air inlet and/or cooling air outlet is clogged with dirt, grass, chaff or other debris, remove it.

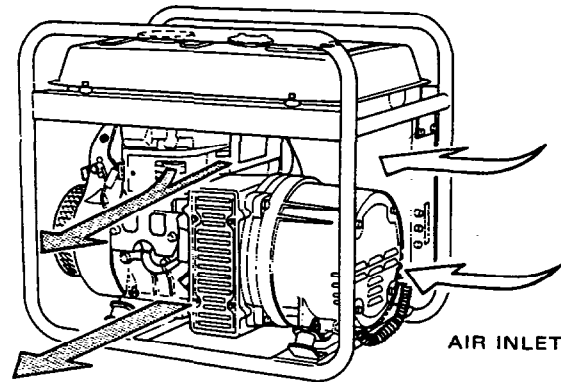

AIR OUTLET

AIR INLET

Fig. 11-8

11-3-5 CHECK THE INSULATION OF THE GENERATOR.

Stop the engine. Measure the insulation resistance between the live terminal of the receptacle and the ground terminal.

If the insulation resistance is less than $1\text{ M}\Omega$, disassemble the generator and check the insulation resistance of the stator, rotor and the live parts in the control box. (Refer to Section 8-3.)

Any part where the insulation resistance is less than $1\text{ M}\Omega$, the insulation is faulty and may cause electric leakage.

Replace the faulty part.

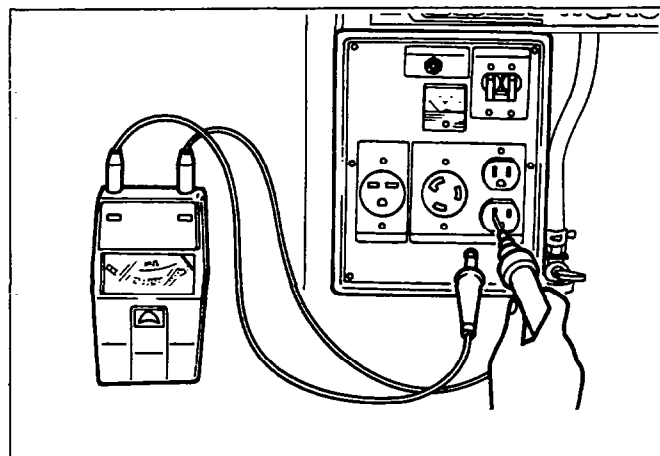

Fig. 11-9

11-4 NO DC OUTPUT

11-4-1 CHECK THE AC OUTPUT.

Check the generator by following Step 11-1-1 through Step 11-1-3.

11-4-2 CHECK THE DC FUSE.

Check the fuse in the fuse holder.

If the fuse is blown, check for the cause of fuse blowing, and then replace with a new one.

FUSE : 10A

NOTE : If the DC output is used to charge a large capacity battery or an over-discharged battery, an excessive current may flow causing fuse blow.

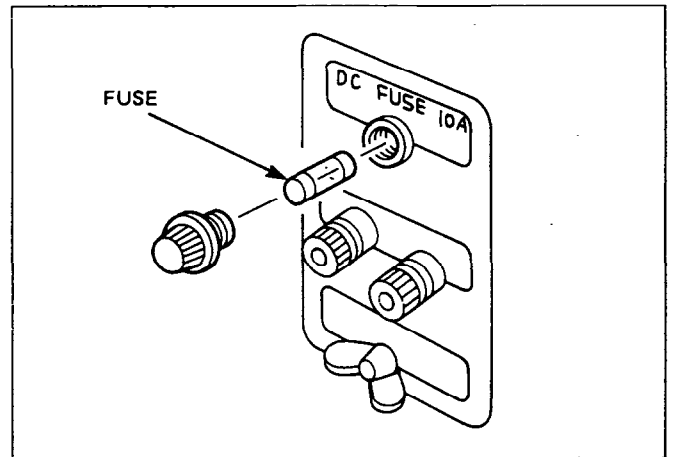

Fig. 11-10

11-4-3 CHECK THE WIRING.

Check all the wires to be connected correctly.

11-4-4 CHECK THE DIODE RECTIFIER.

Remove the control panel and check the diode rectifier with a circuit tester.

Refer to Section 9-7 "DIODE RECTIFIER" for the checking procedure.

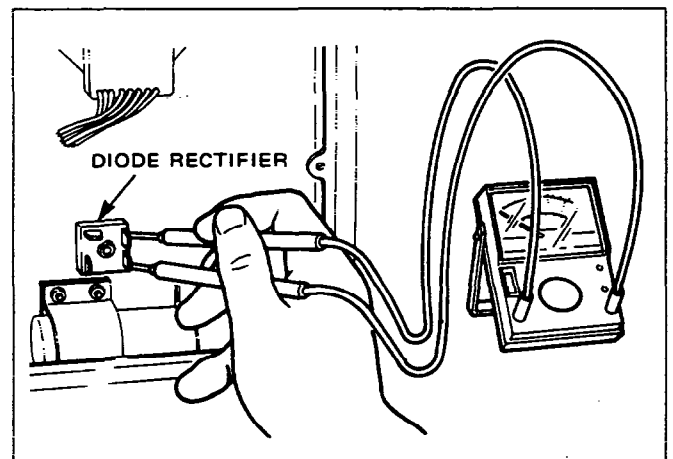

Fig. 11-11

11-4-5 CHECK THE DC COIL

Check the resistance between two brown leads from stator with a circuit tester.

MODEL		SPECIFICATION	RESISTANCE
RGX1800	50Hz	110V, 220V, 240V, 110V/220V	0.41Ω
	60Hz	120V, 220V, 110V/220V, 120V/240V	0.35Ω
RGX2400	50Hz	110V, 220V, 240V, 110V/220V	0.29Ω
	60Hz	120V, 220V, 110V/220V, 120V/240V	0.27Ω
RGX3500	50Hz	110V, 220V, 240V, 110V/220V	0.26Ω
	60Hz	120V, 220V, 110V/220V, 120V/240V	0.22Ω
RGX5500	50Hz	110V, 220V, 240V, 110V/220V	0.15Ω
	60Hz	120V, 220V, 110V/220V, 120V/240V	0.14Ω

Table 11-3

If the resistance reading is much larger or smaller than the specified value, the DC coil of the stator is faulty. Replace stator with a new one.

11-5 IDLE CONTROL (OPTIONAL EQUIPMENT)

11-5-1 ENGINE SPEED IS NOT INCREASED WHEN A LOAD IS APPLIED

- (1) Inspect the solenoid bracket.
Check the bend angle of solenoid bracket.
If the bracket is distorted, correct the angle with proper tool.

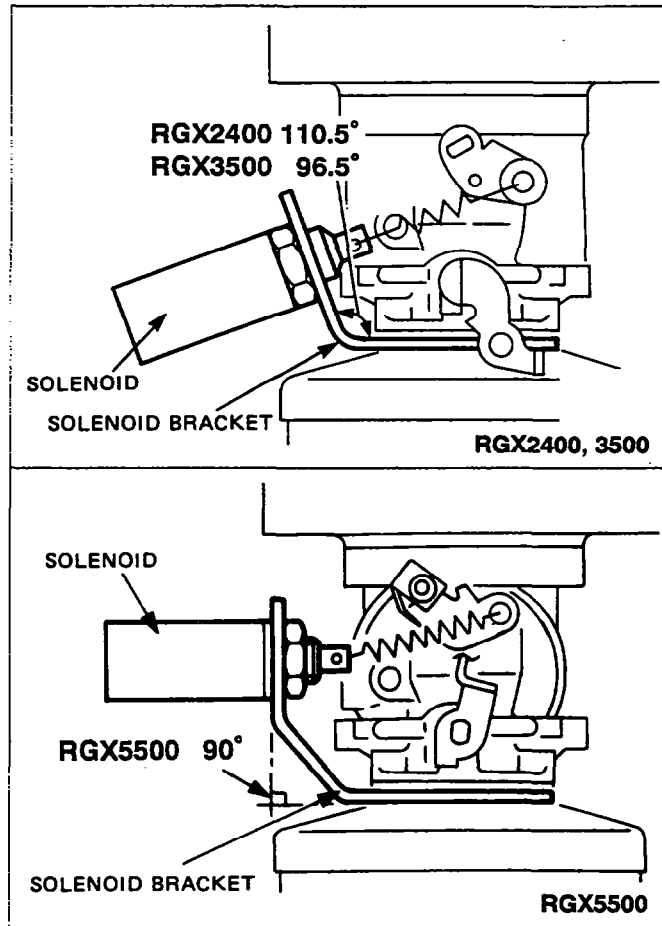

Fig. 11-12

- (2) Check the wattage of load applied to the generator.
If the generator is loaded over the rated wattage, the engine speed can not be increased.
Most induction loads such as electric motor or electric tools or welding machine require three to five times large wattage of their ratings at starting.
This starting wattage must not exceed the rated output of the generator.

- (3) Check the slow set r.p.m.
The normal idling speed by the IDLE CONTROL is as follows :

RGX2400, 3500 3150 ~ 3200 r.p.m.

RGX5500 2700 ~ 2800 r.p.m.

Adjust the idling speed monitoring the volt-meter so that it indicates between 75 volt and 85 volt.

- Turn the adjusting screw to adjust the slow speed.

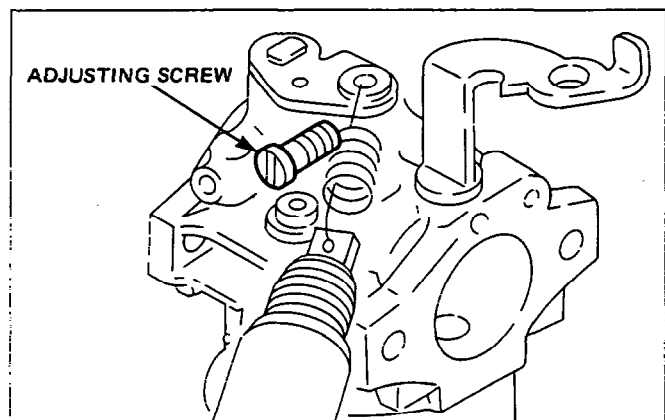

Fig. 11-13

(4) Check the wiring through ZCT on the IDLE CONTROL UNIT BOARD.

A) Single Voltage Type

Make sure that an output wire from main coil is passing through the ZCT on the IDLE CONTROL UNIT.

B) Dual Voltage Type

Check that two output wires (black wire and red wire) from main coils are passing through the ZCT on the IDLE CONTROL UNIT in the same direction.

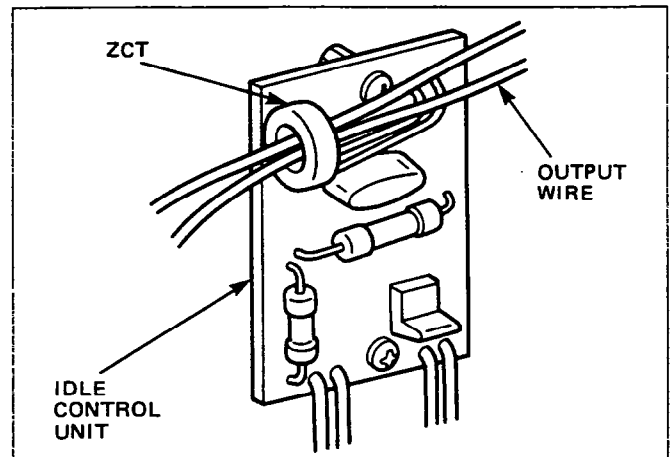

Fig. 11-14

(5) Checking the IDLE CONTROL UNIT

Check the resistance between six leads of IDLE CONTROL UNIT with circuit tester.

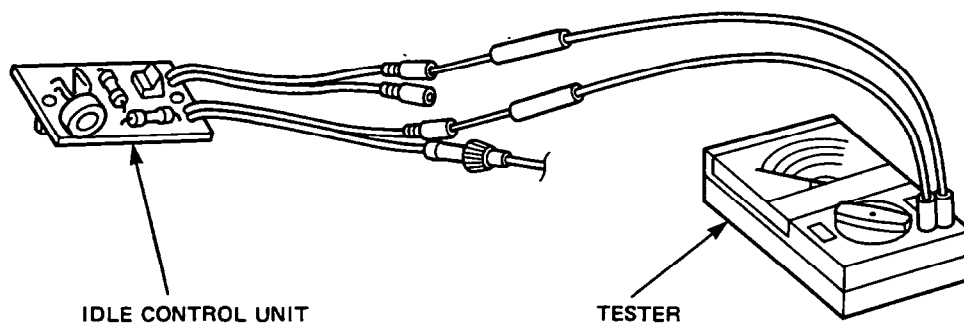

Fig. 11-15

Tester Polarity	WHITE	LIGHT BLUE (FUSE)	LIGHT BLUE	RED
	(+)	(-)	(+)	(-)
WHITE		Larger than 190kΩ	Larger than 85kΩ	Larger than 85kΩ
LIGHT BLUE (FUSE)	∞		∞	∞
LIGHT BLUE	20-50kΩ	2-16kΩ		0
RED	20-50kΩ	2-16kΩ	0	

Table 11-4

NOTE : Take $\pm 10\%$ tolerance on above resistance value.

If the measurement differs largely from normal value, the IDLE CONTROL UNIT is defective. Replace with a new one.

11-5-2 ENGINE SPEED IS NOT REDUCED WHEN LOAD IS OFF.

- (1) Check the distortion of the SOLENOID BRACKET as shown in step 11-5-1-(1).
- (2) Check the FUSE on wiring of IDLE CONTROL UNIT.
 - Remove the control panel from control box.
 - Check the FUSE in the fuse holder of IDLE CONTROL UNIT.If fuse is blown, replace with a new one. (FUSE : 0.3A)

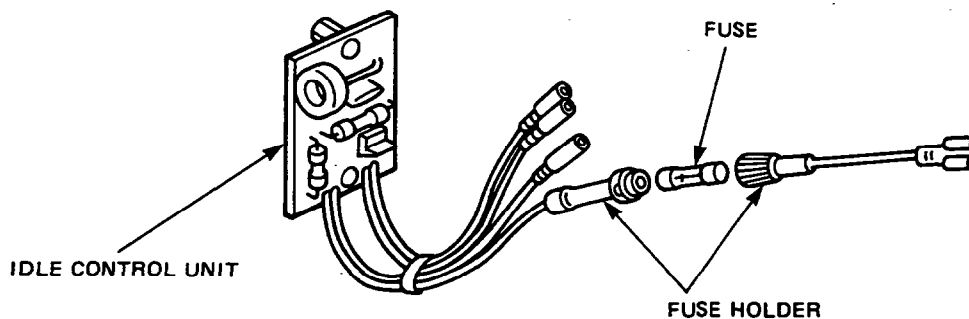

Fig. 11-16

- (3) Check the wiring of SOLENOID.
Check two leads from SOLENOID are securely connected.
- (4) Check the wiring of IDLE CONTROL UNIT.
Check all leads from IDLE CONTROL UNIT are securely and correctly connected.

- (5) Checking the SOLENOID.
Measure the resistance between two leads from SOLENOID.

NORMAL RESISTANCE
235 ~ 290 Ω

If the resistance is larger or smaller than this range, SOLENOID is defective,
Replace with a new one.

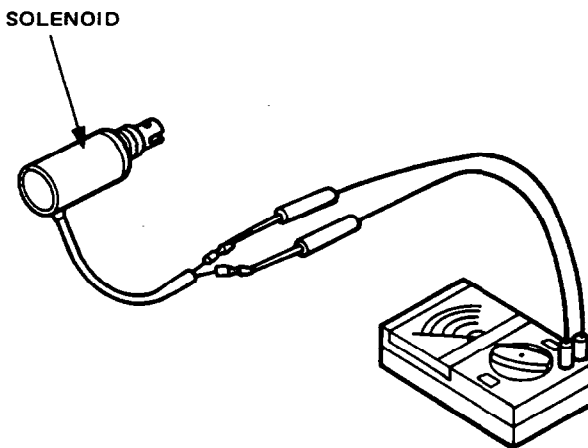
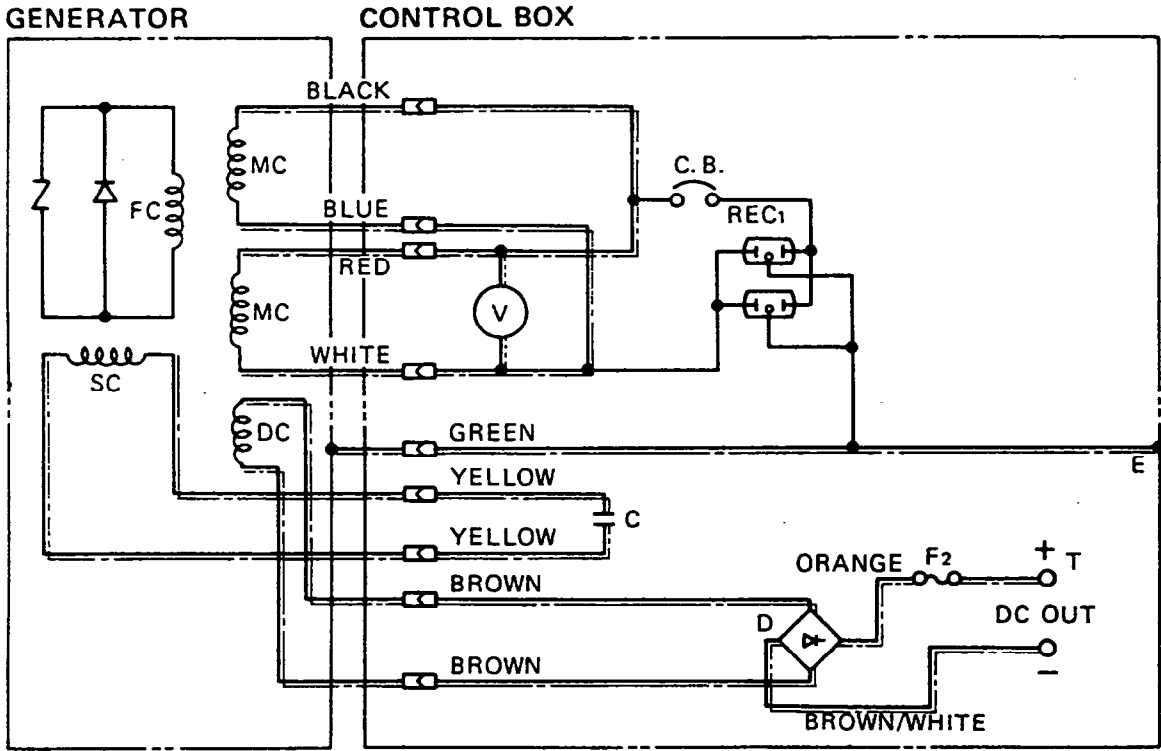

Fig. 11-17

12. WIRING DIAGRAM

- RGX1800 : 50Hz-110V, 60Hz-120V TYPE



- RGX2400 : 50Hz-110V, 60Hz-120V TYPE

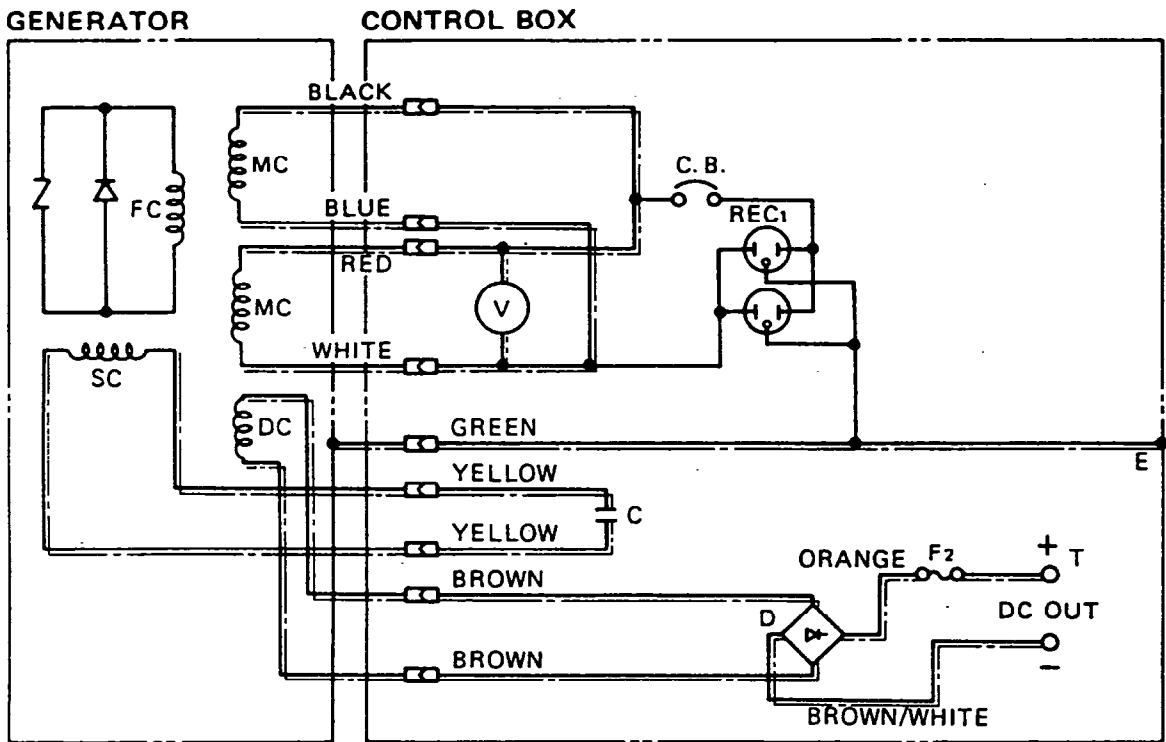



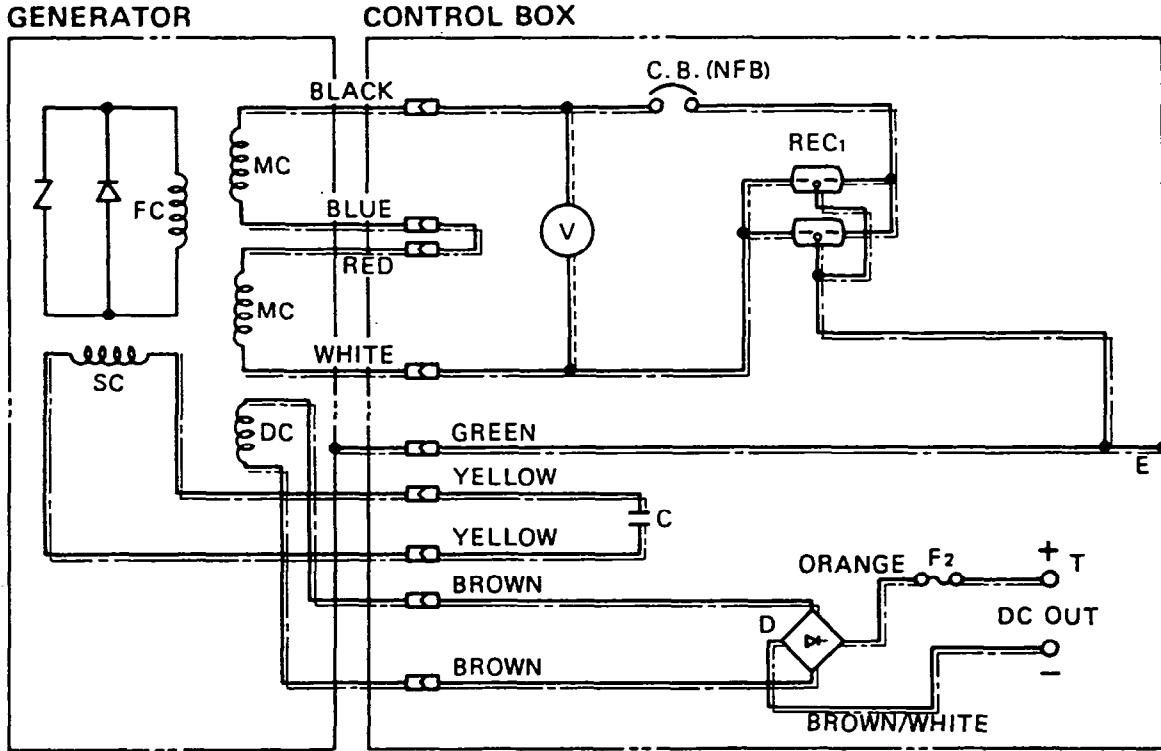

0.75 mm²
 2.0 mm²
 1.25 mm²
 3.5 mm²

● RGX1800, 2400 : 50Hz-220V, 240V, 60Hz-220V TYPE

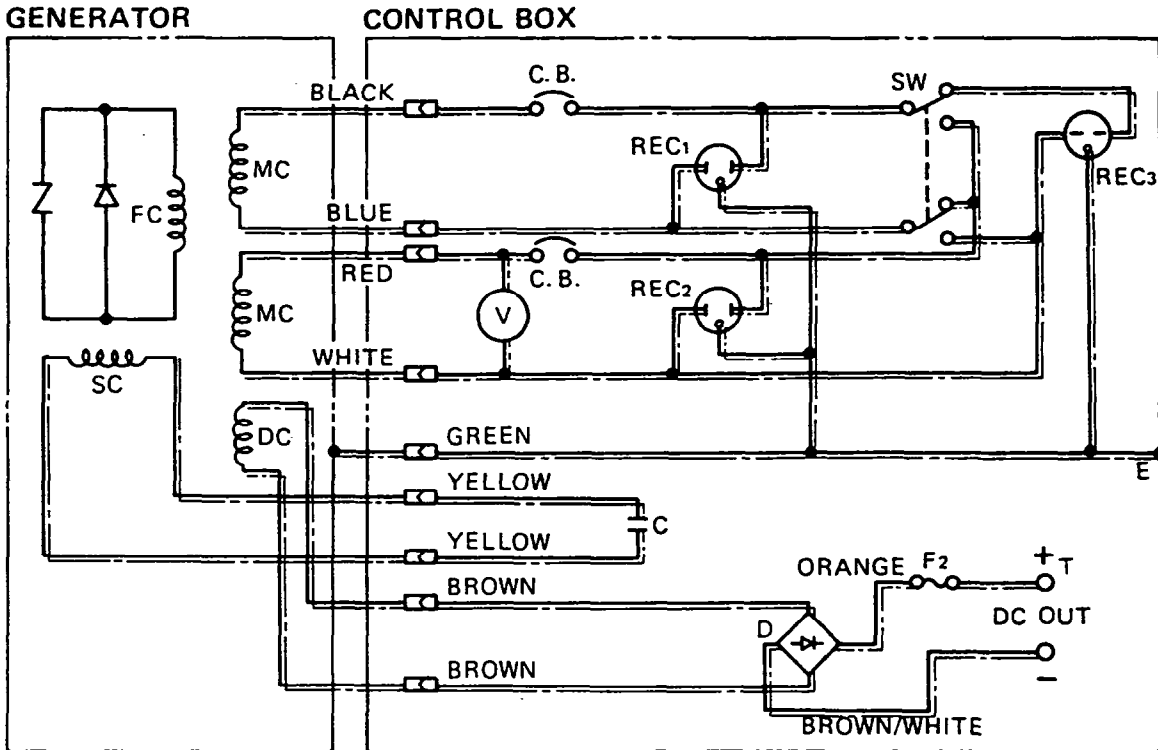

● RGX1800, 2400 : 50Hz, 60Hz-110V/220V TYPE



	0.75 mm ²		2.0 mm ²
	1.25 mm ²		3.5 mm ²

● RGX1800, 2400 : U.K., 50Hz-110V/220V [BS RECEPTACLE]

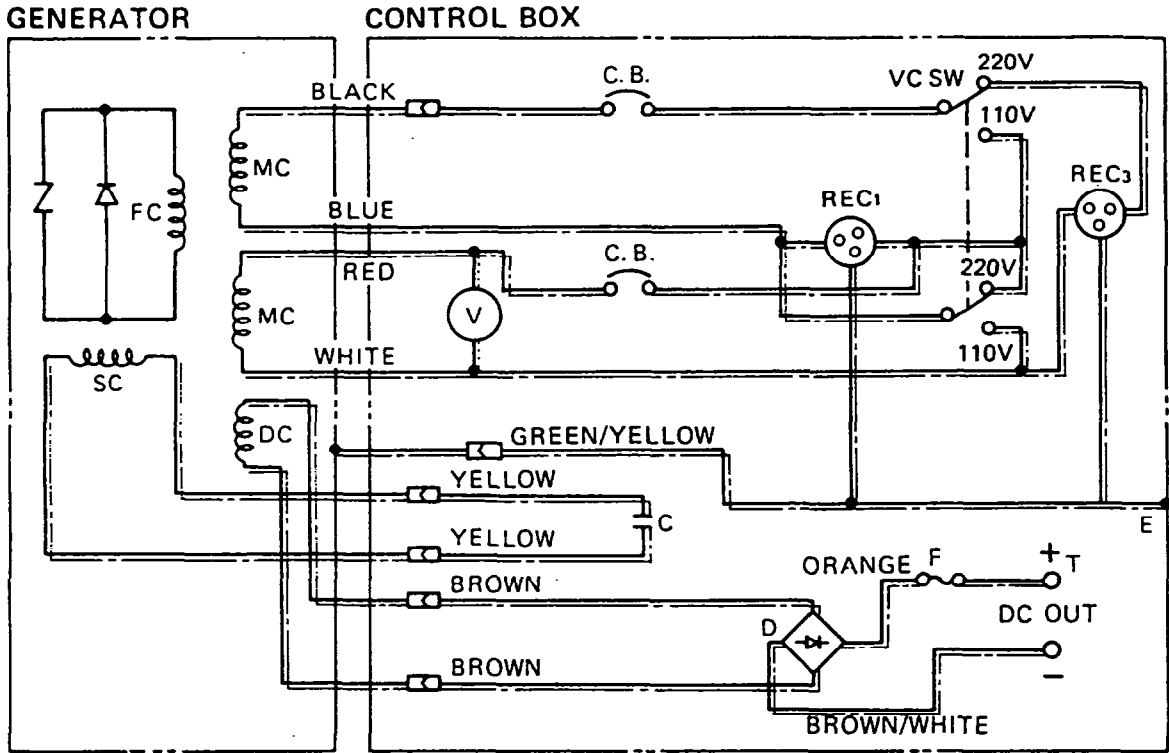

● RGX2400 : U.S.A., 60Hz-120V [NEMA RECEPTACLE with IDLE CONTROL]

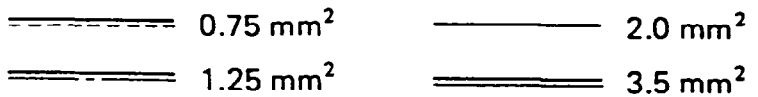
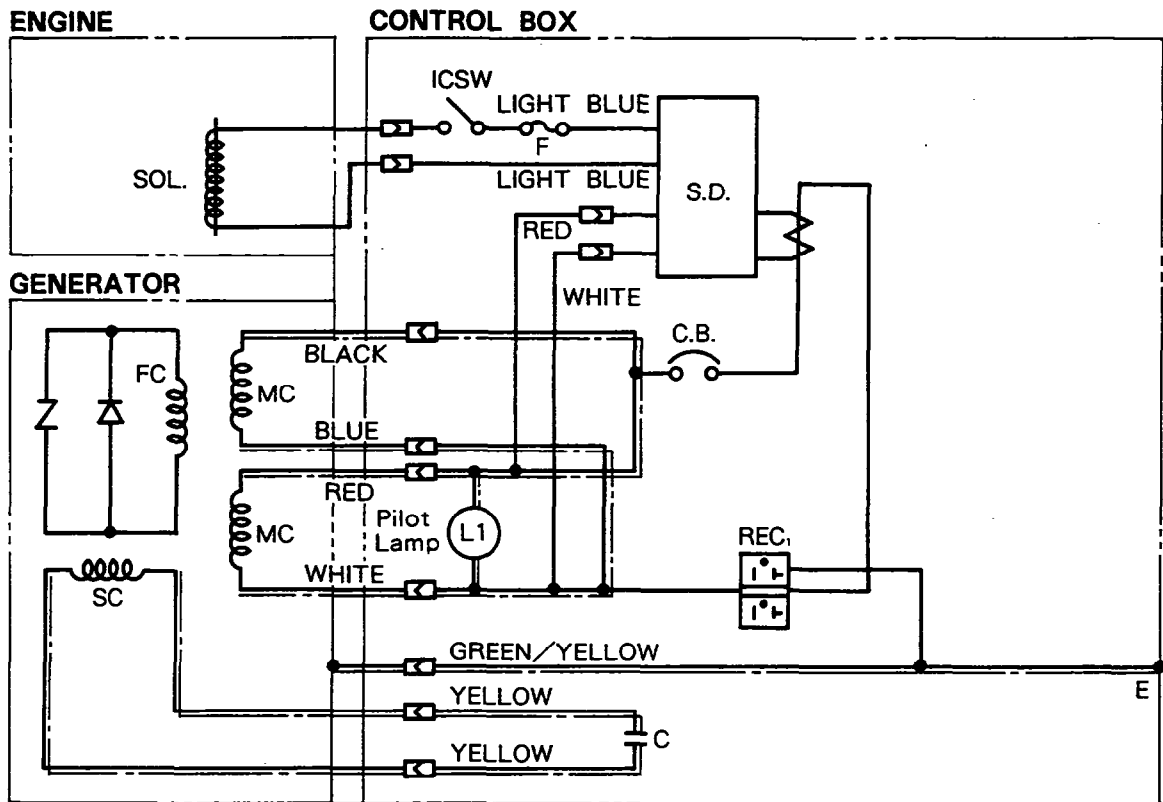

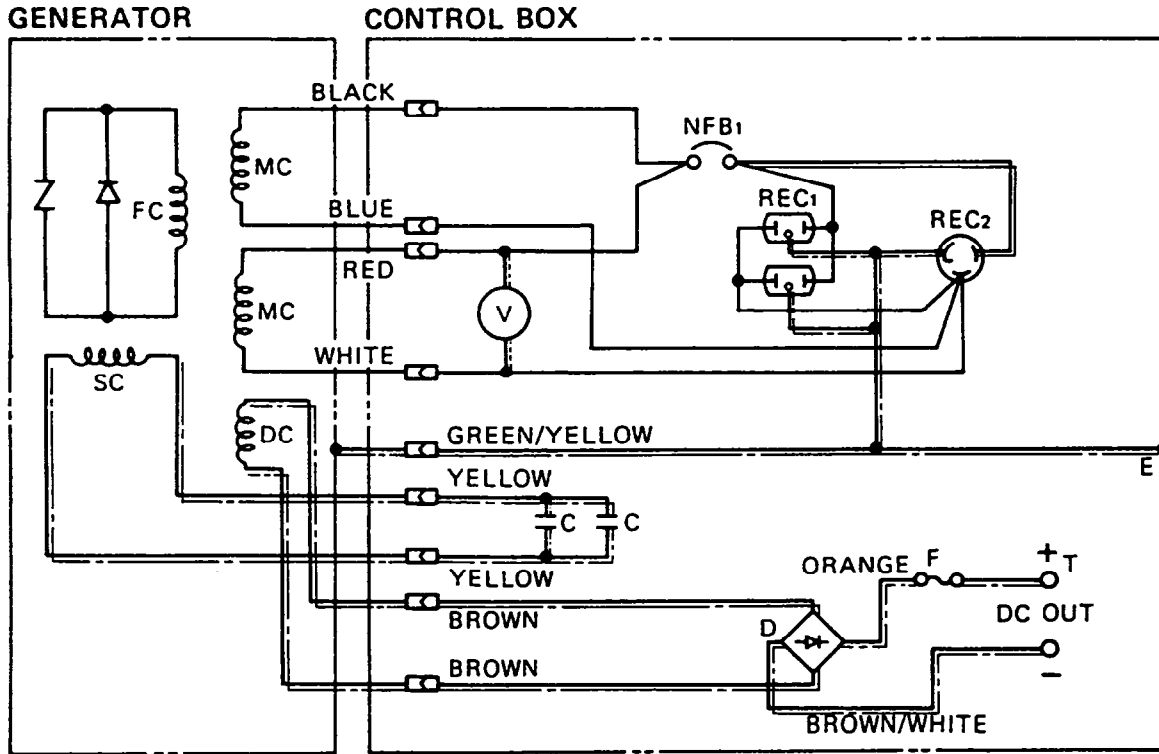

● RGX3500 : 50Hz-110V, 60Hz-120V TYPE

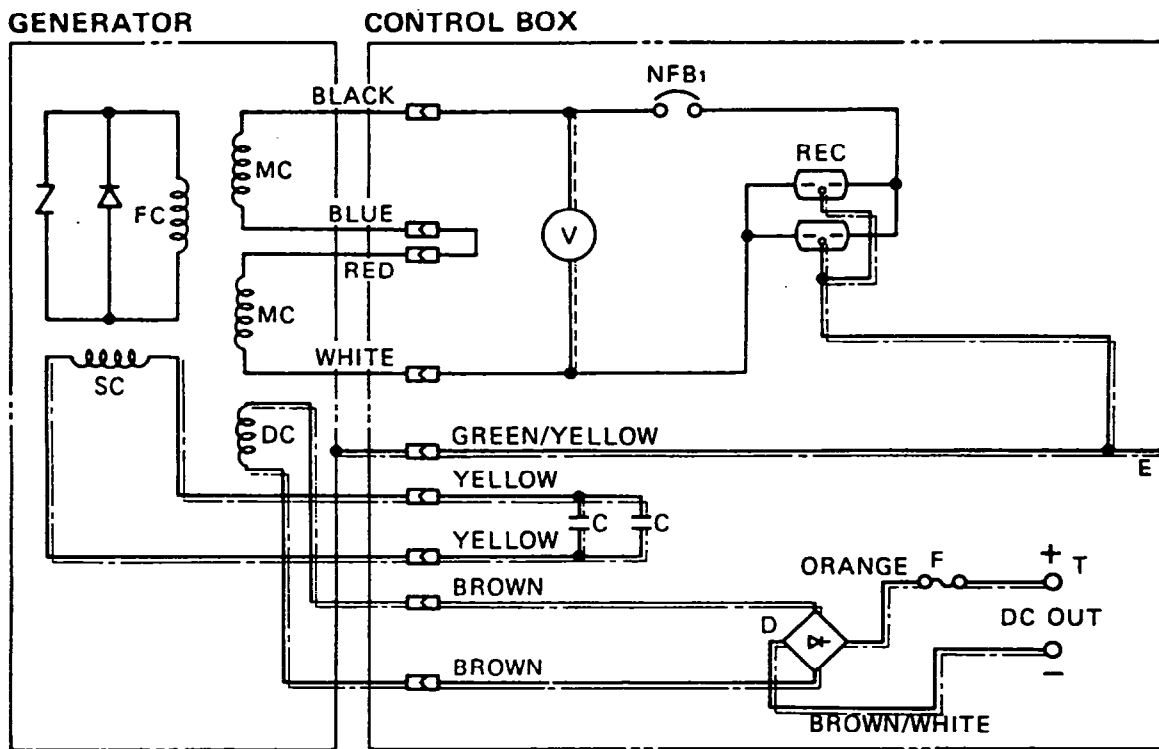

● RGX3500 : 50Hz-220V, 240V, 60Hz-220V TYPE

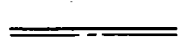
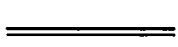

	0.75 mm ²		2.0 mm ²
	1.25 mm ²		3.5 mm ²

● RGX3500 : 50Hz, 60Hz-110V/220V TYPE

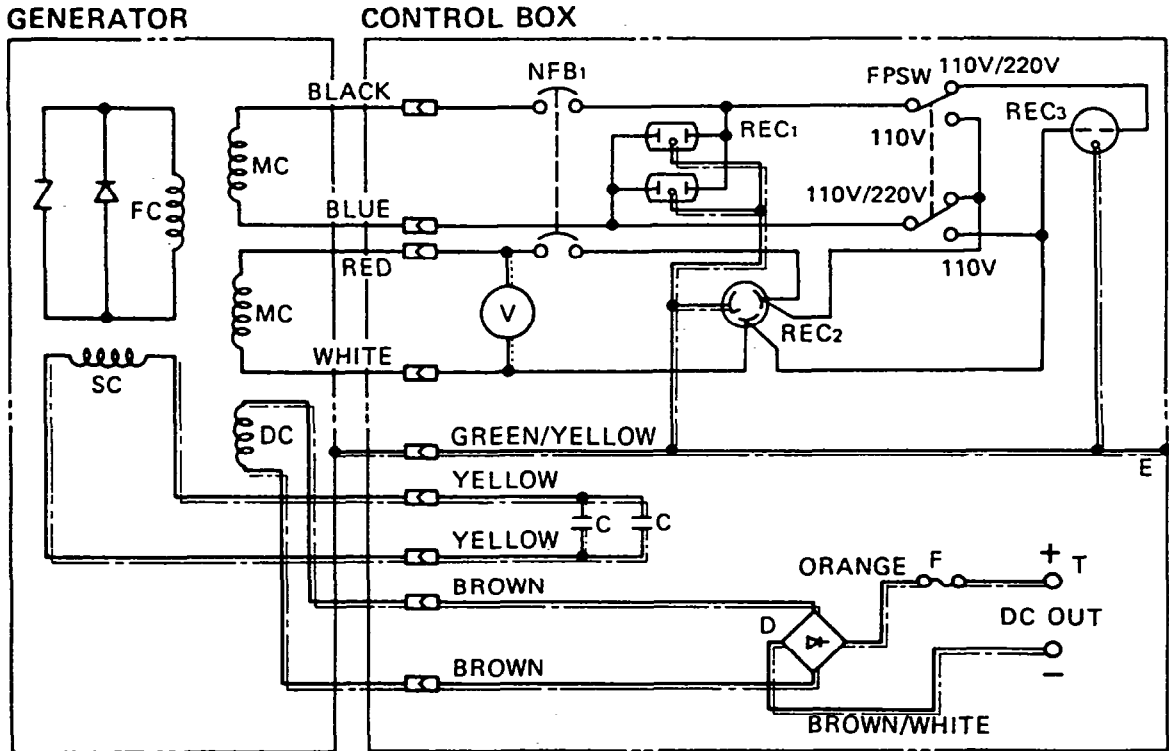

● RGX3500 : U.K., 50Hz-110V/220V [BS RECEPTACLE]

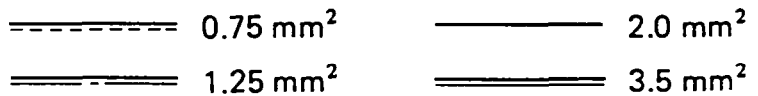
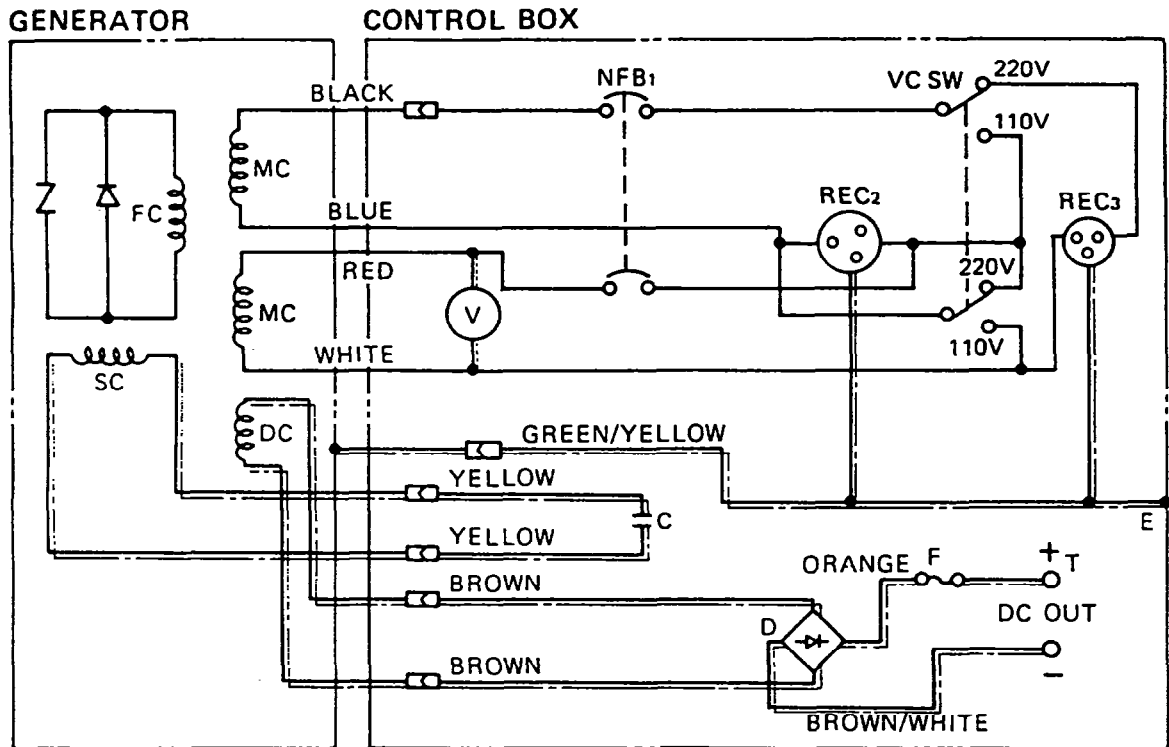

● RGX3500 : U.S.A., 60Hz-120V/240V [NEMA RECEPTACLE with IDLE CONTROL]

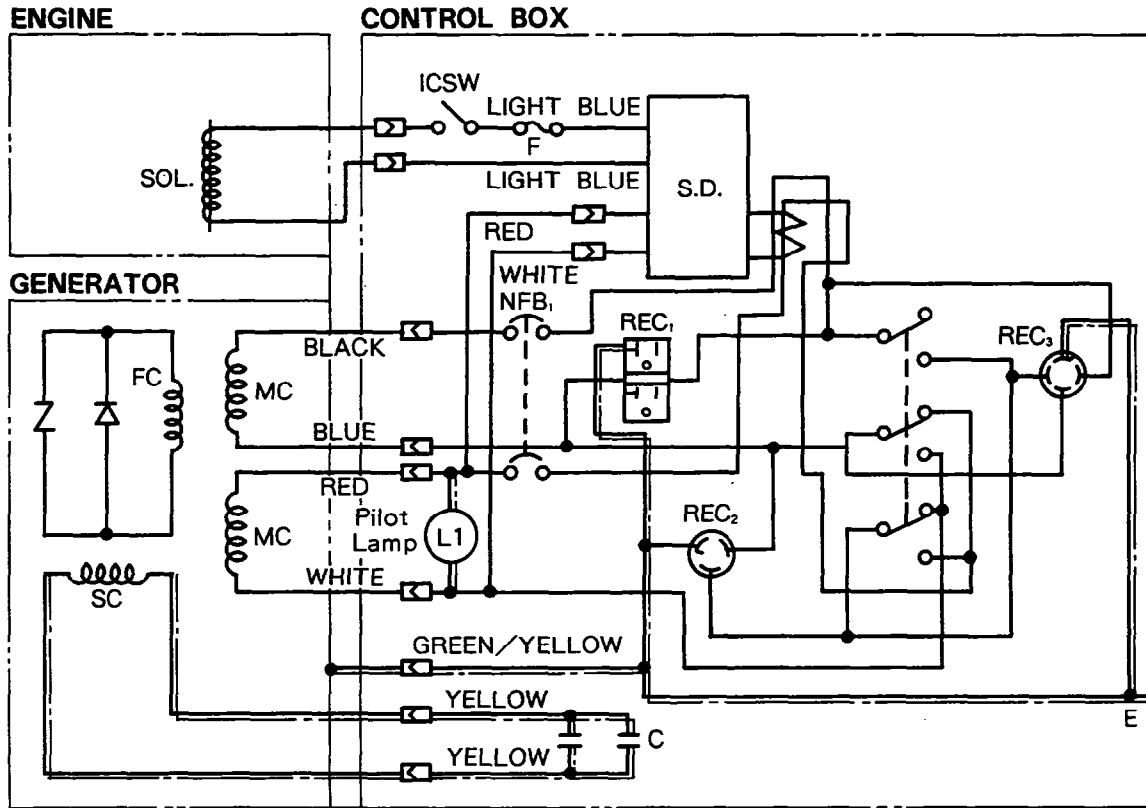

● RGX5500 : 50Hz-110V, 60Hz-120V TYPE

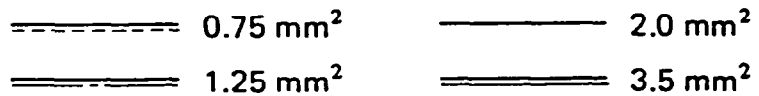
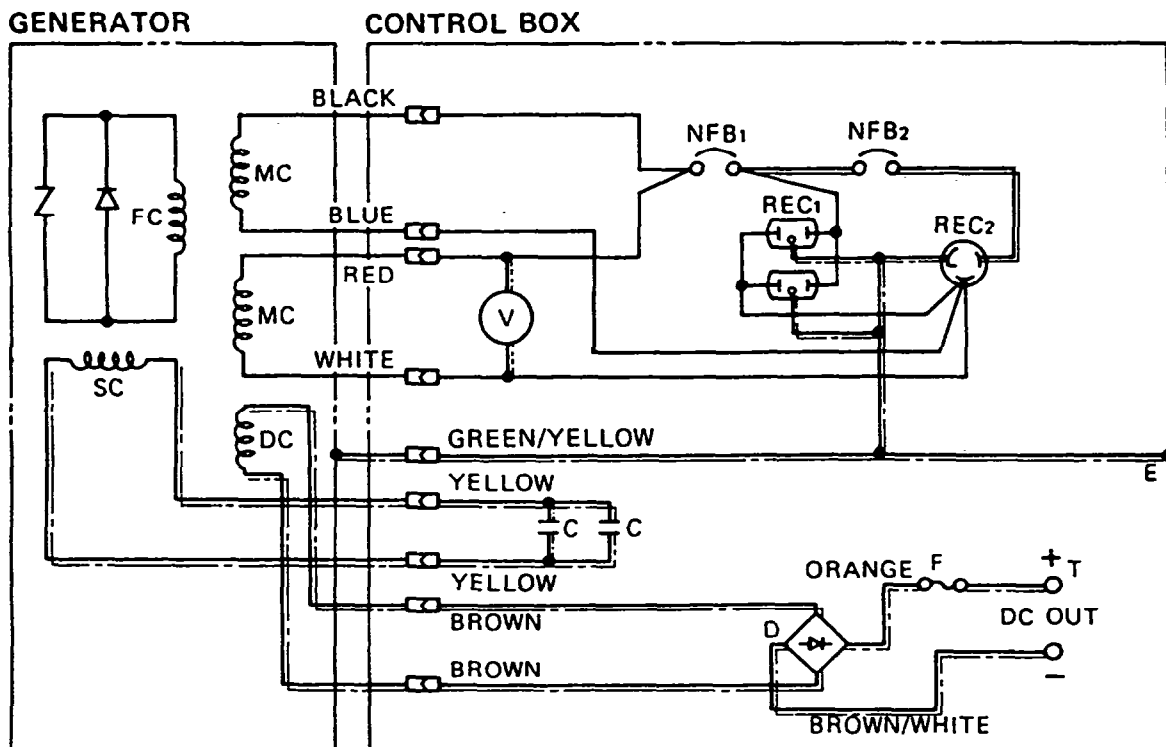

● RGX5500 : 50Hz-220V, 240V, 60Hz-220V TYPE

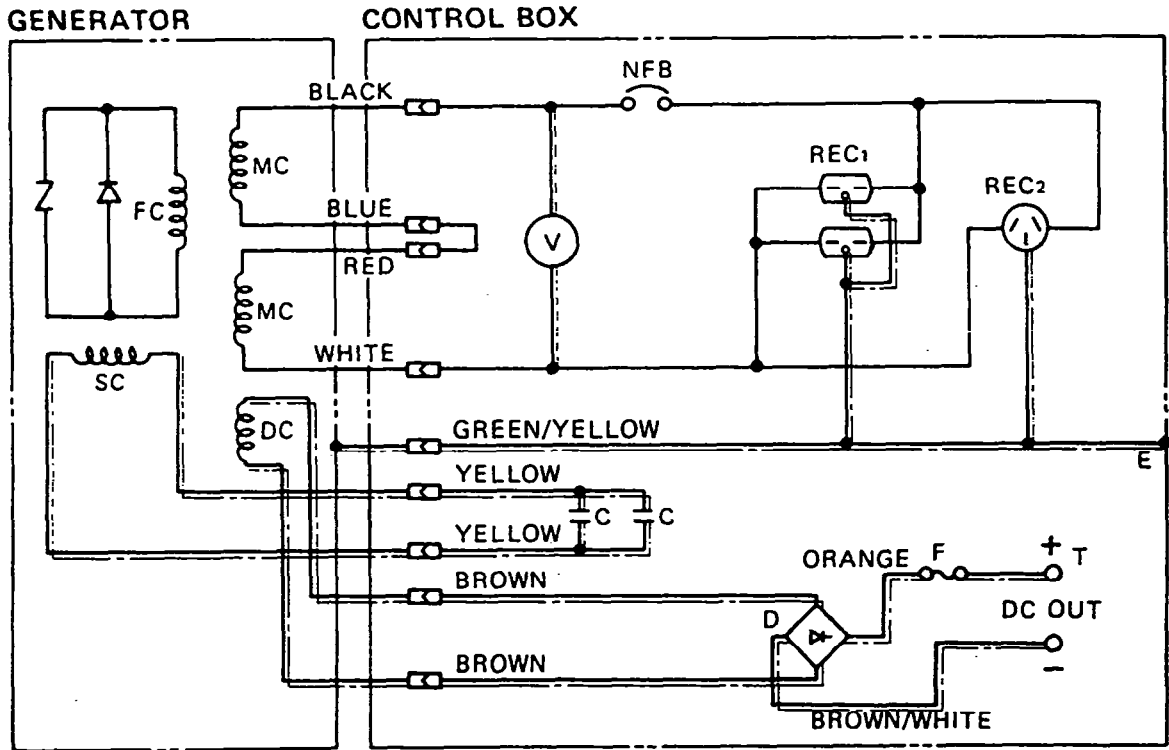

● RGX5500 : 50Hz, 60Hz-110V/220V TYPE

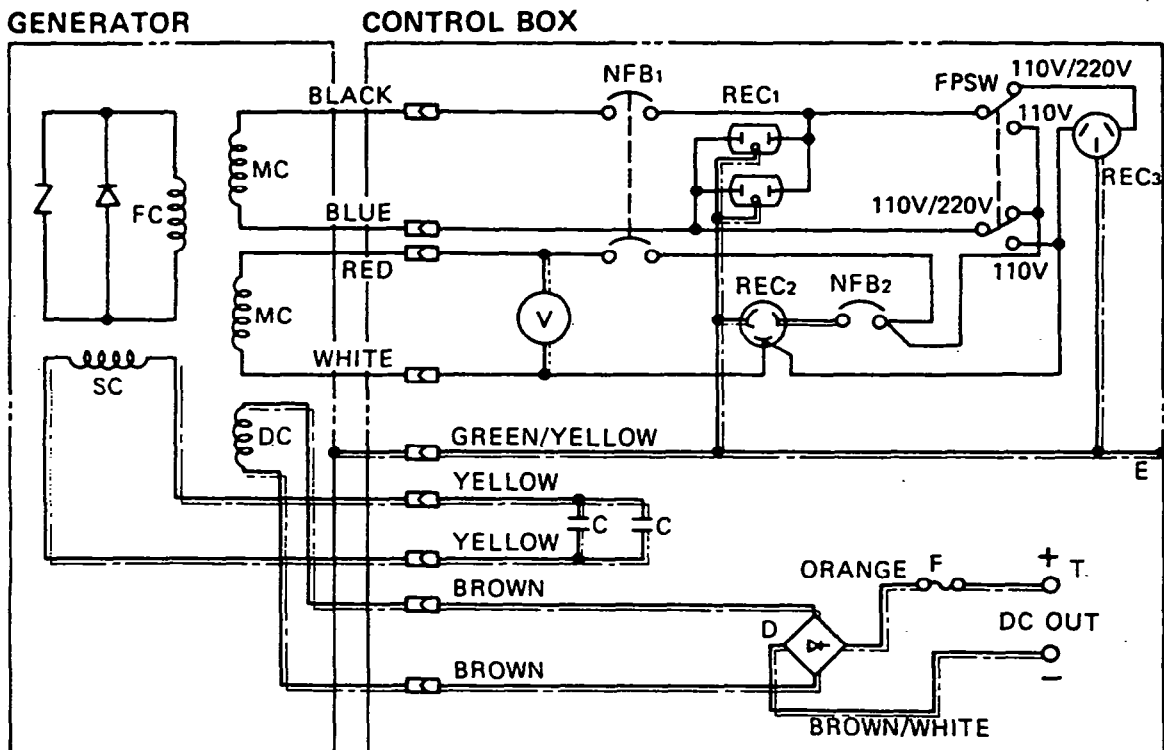

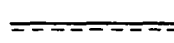
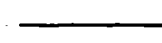
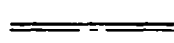
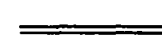
	0.75 mm ²		2.0 mm ²
	1.25 mm ²		3.5 mm ²

● RGX5500 : U.K., 50Hz-110V/220V [BS RECEPTACLE]

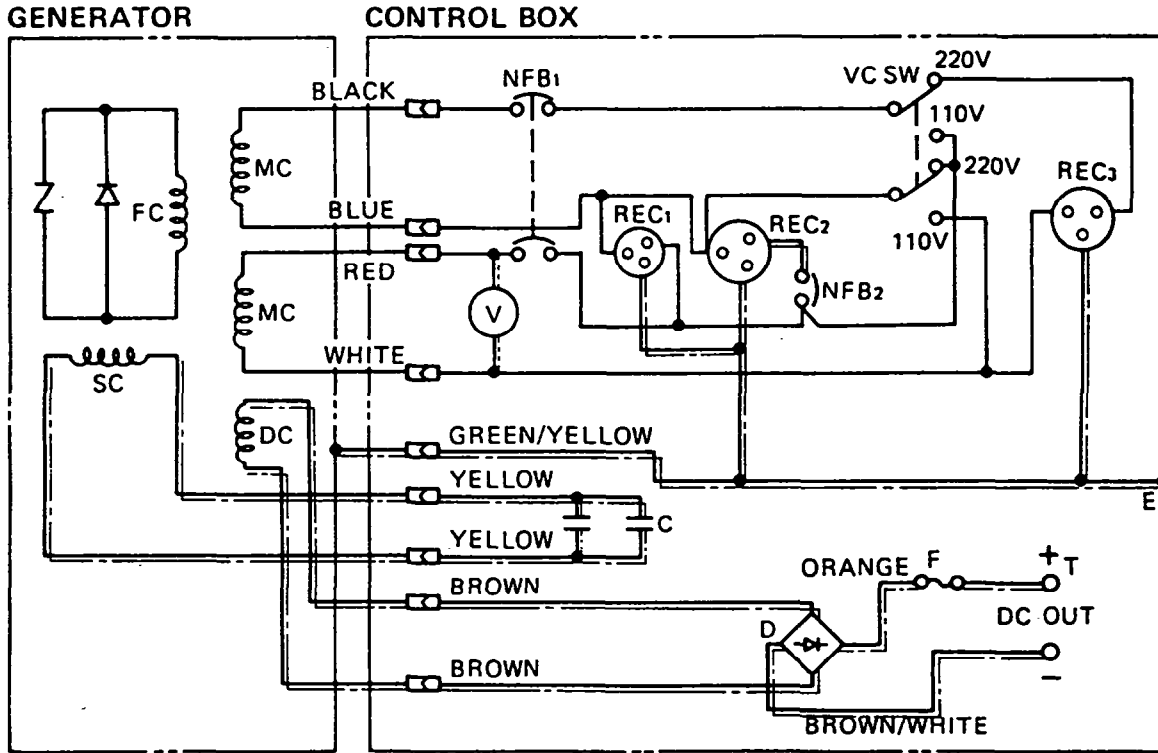

● RGX5500 : U.S.A., 60Hz-120V/240V [NEMA RECEPTACLE with IDLE CONTROL]

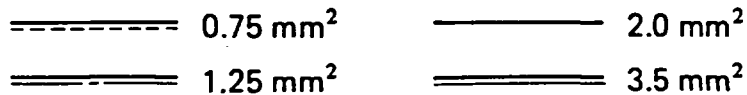
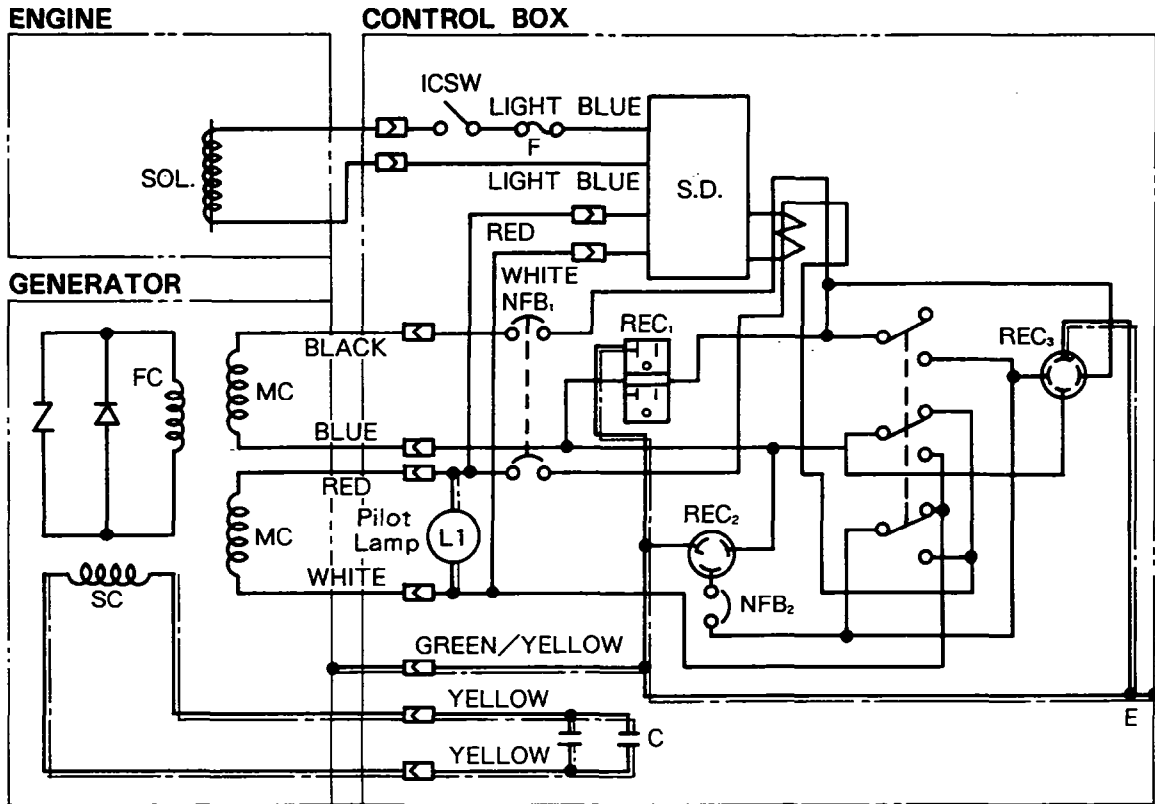

● TYPE WITH OIL SENSOR (Optional Equipment)

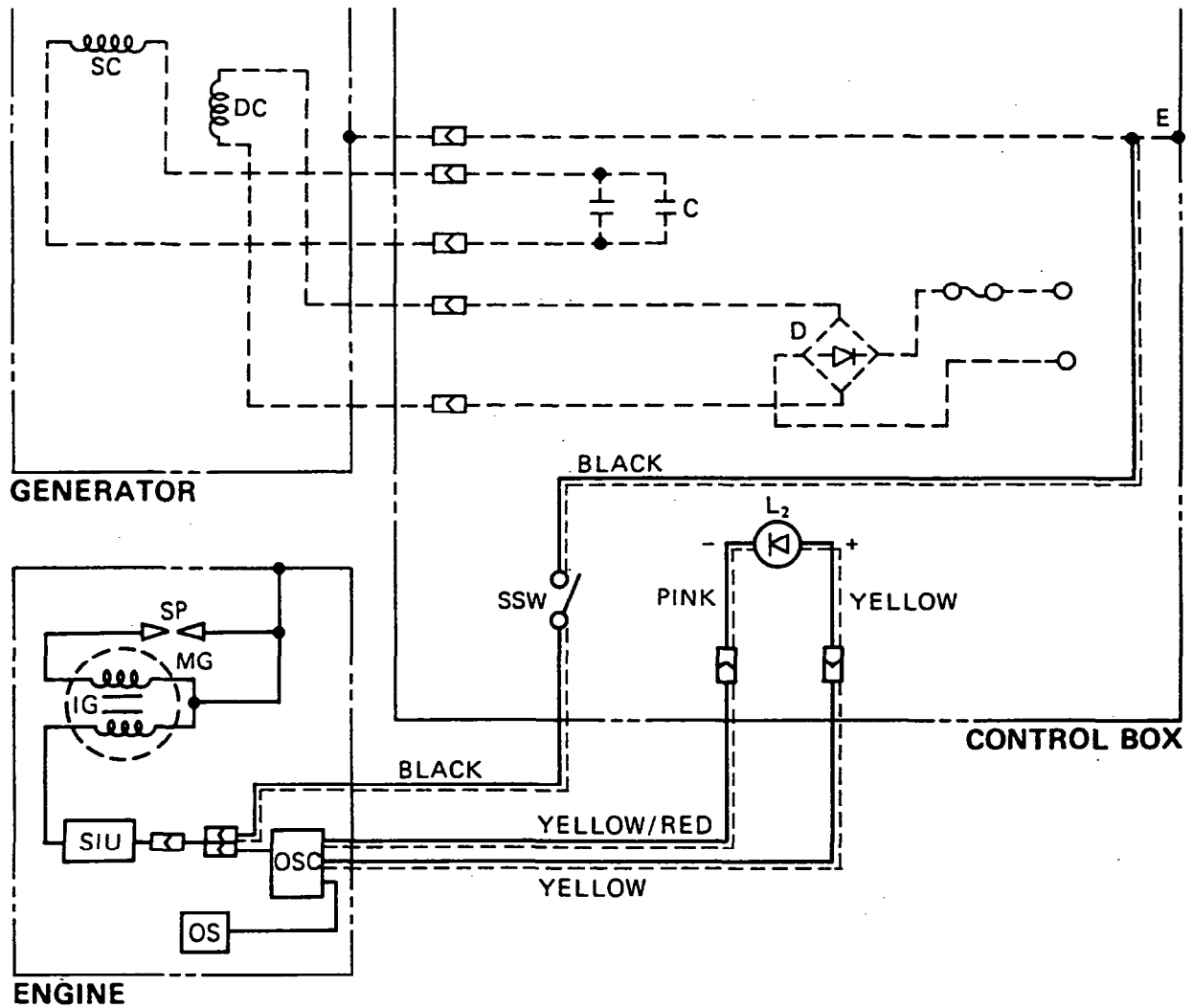

- 0.75 mm²
- 1.25 mm²
- 2.0 mm²
- ===== 3.5 mm²

● RGX3500 : ELECTRIC STARTER TYPE (Optional Equipment)

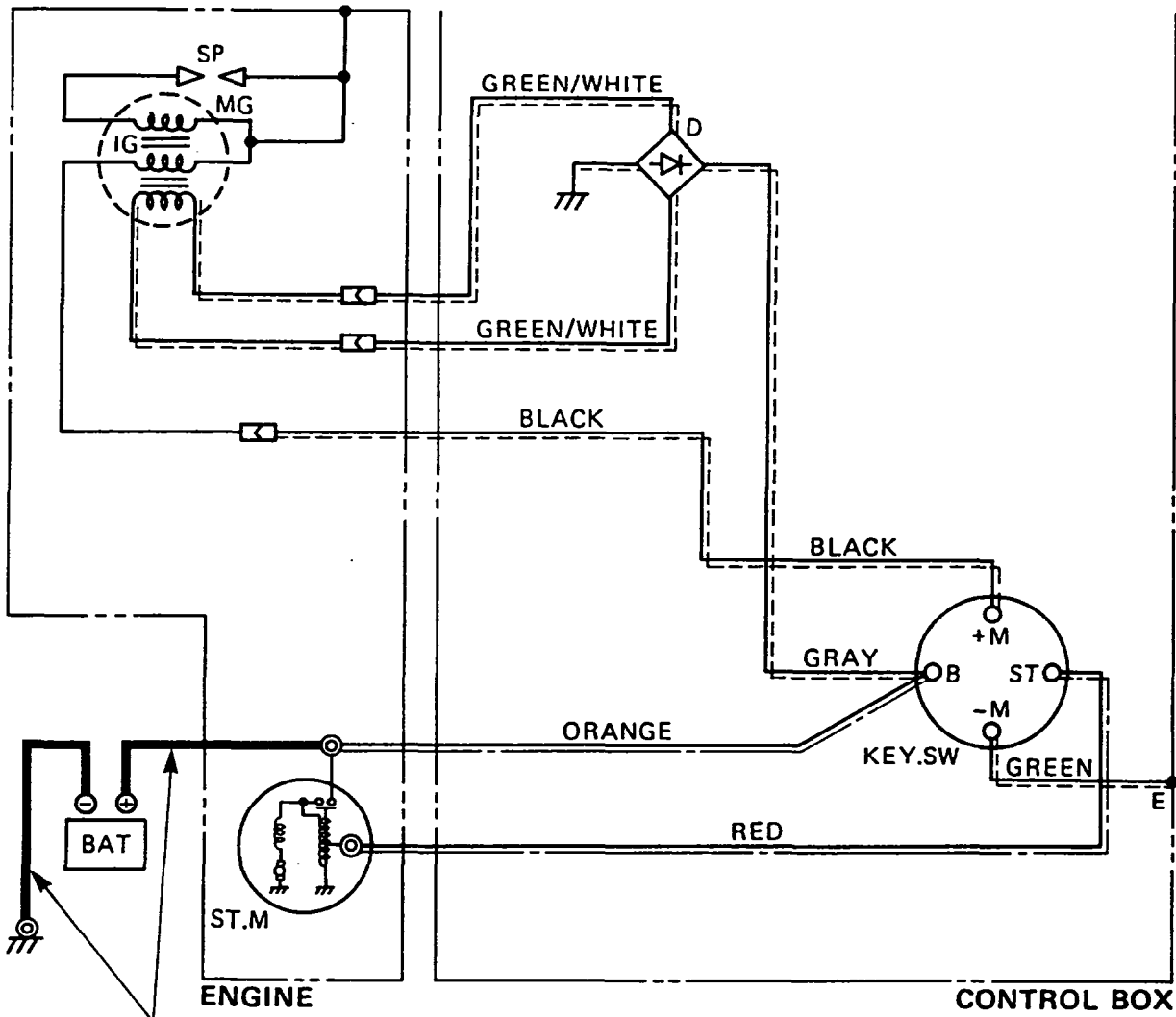

The battery cords have a cross sectional area of 22 mm².

- 0.75 mm²
- ==== 1.25 mm²
- _____ 2.0 mm²
- ===== 3.5 mm²

● RGX5500 : ELECTRIC STARTER TYPE (Optional Equipment)

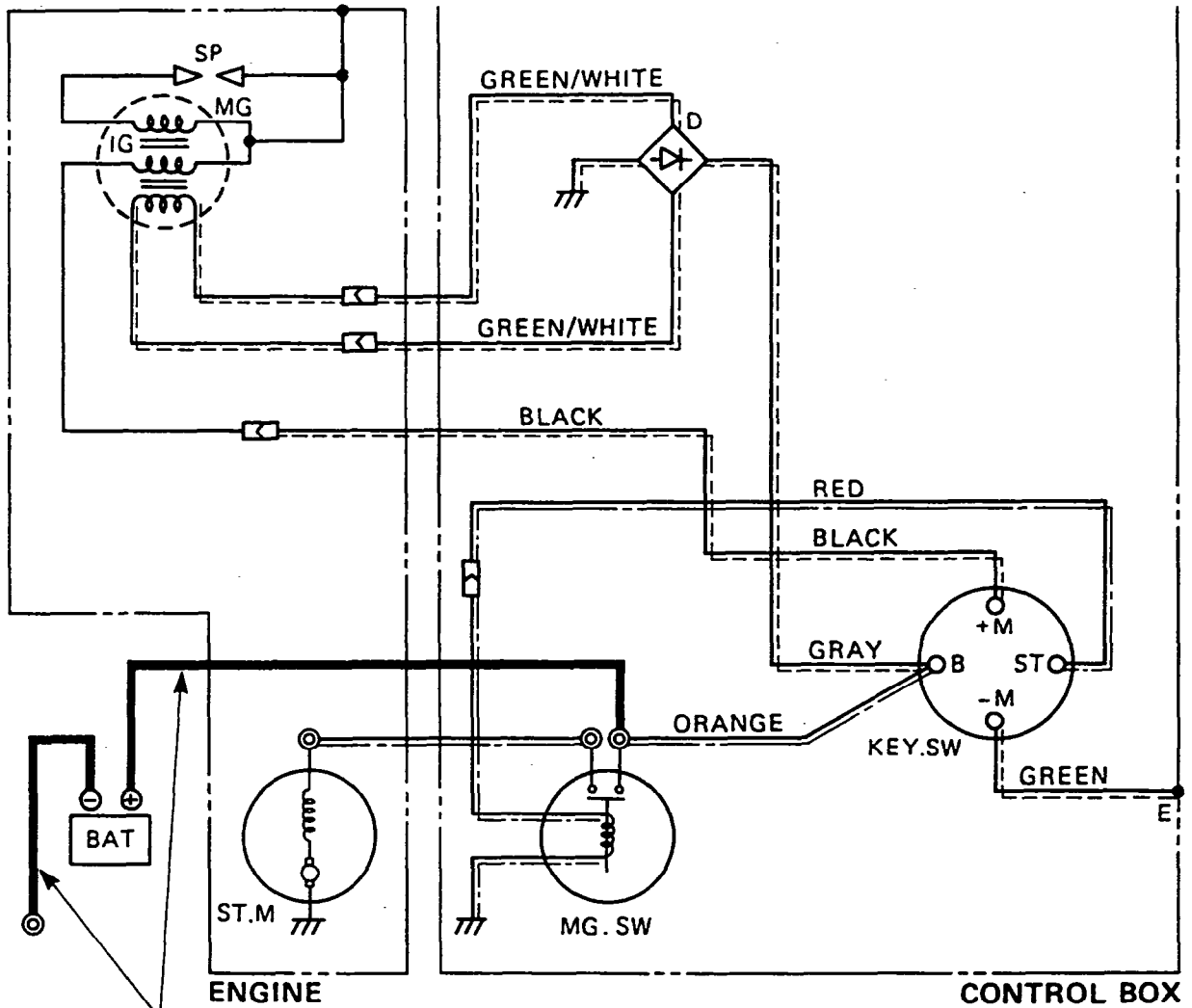



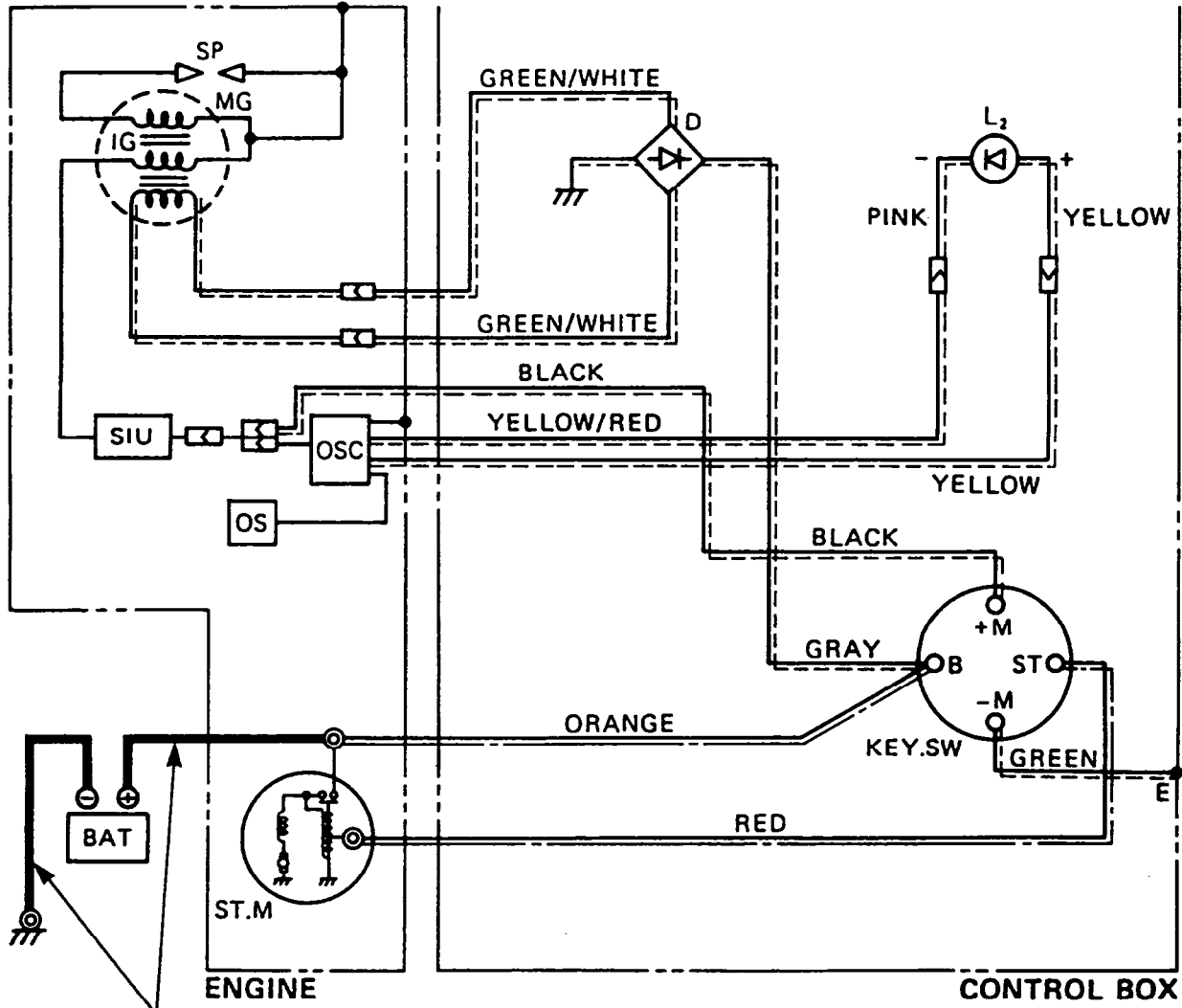

The battery cords have a cross sectional area of 22 mm².

- ===== 0.75 mm²
- =====
===== 1.25 mm²
- 2.0 mm²
- =====
===== 3.5 mm²

● RGX3500 : ELECTRIC STARTER TYPE WITH OIL SENSOR (Optional Equipment)



The battery cords have a cross sectional area of 22 mm².

-  0.75 mm²
-  1.25 mm²
-  2.0 mm²
-  3.5 mm²

● RGX5500 : ELECTRIC STARTER TYPE WITH OIL SENSOR (Optional Equipment)

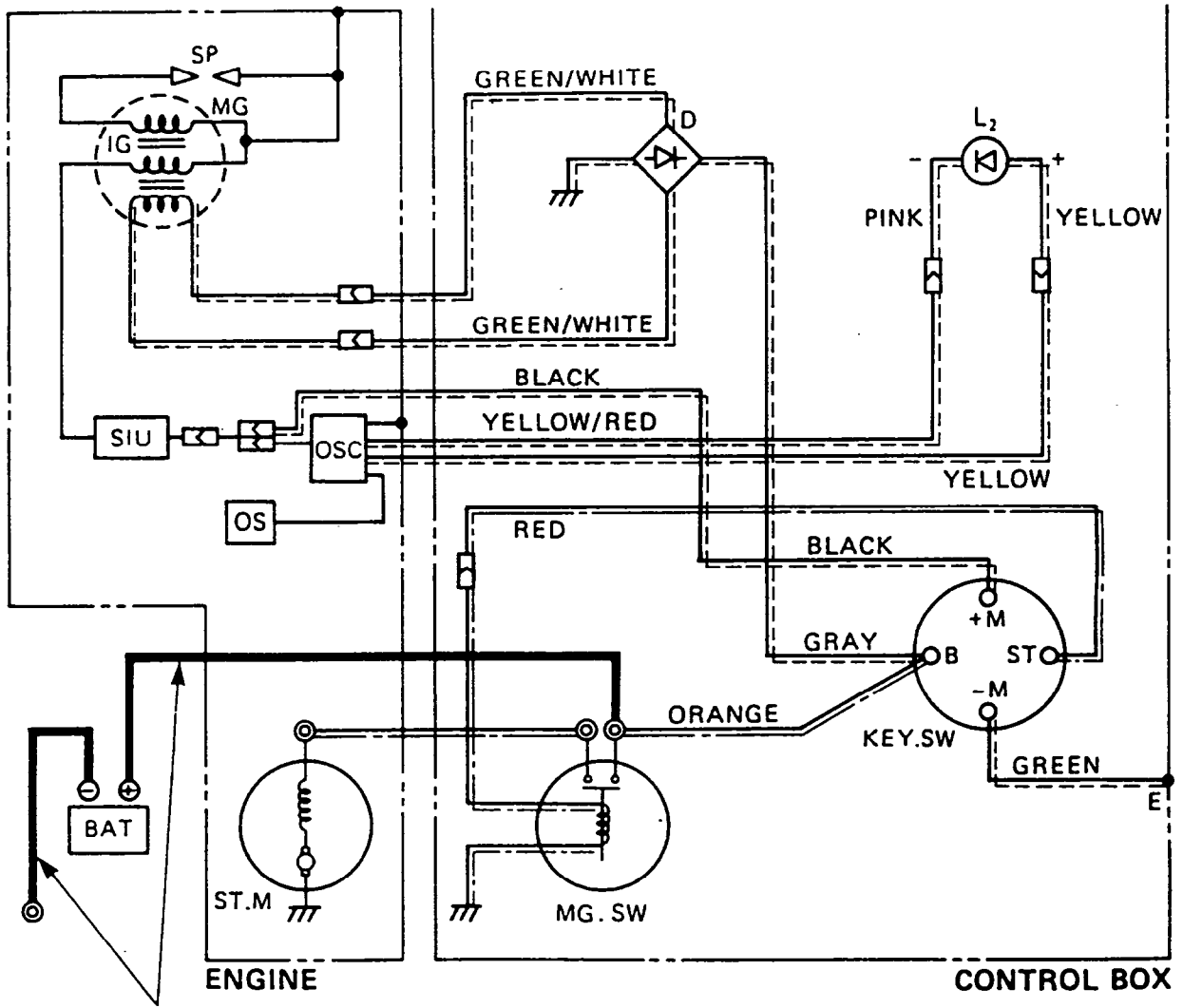

The battery cords have a cross sectional area of 22 mm².

- 0.75 mm²
- ==== 1.25 mm²
- _____ 2.0 mm²
- ===== 3.5 mm²

Symbols	Part Name
MC	AC Winding
SC	Auxiliary Winding
DC	DC Winding
FC	Field Winding
C	Condenser
D	Diodes Stack Assy
L ₁	Pilot Lamp
L ₂	Warning Lamp (Oil sensor)
T	DC Output Terminal
F	Fuse
C.B.	Circuit Breaker
NFB ₁	No-Fuse Breaker
NFB ₂	No-Fuse Breaker
VC SW	Voltage Changeover Switch
FP SW	Full Power Switch
S SW	Engine Stop Switch
OS	Oil Sensor
OSC	Oil Sensor Controller
SIU	Solid State Ignition Unit
SP	Spark Plug
MG	Magneto
IG	Ignition Coil
MG, SW	Magnetic Switch
E	Earth Terminal (Ground Terminal)
ST. M	Starting Motor
KEY SW	Key Switch
BAT	Battery
V	Voltmeter
REC ₁	AC Output Receptacle (Total 15A MAX.)
REC ₂	AC Output Receptacle (220V/240V)
REC ₃	AC Output Receptacle (110V/120V)
REC ₄	AC Output Receptacle (120V/240V)
REC ₅	AC Output Receptacle (Total 20A MAX.)

Robin America, Inc.

940 Lively Blvd. • Wood Dale, IL 60191 • Phone: 630-350-8200 • Fax: 630-350-8212
e-mail: sales@robinamerica.com • www.robinamerica.com

PRINTED IN THE USA

Robin America, Inc.